

Wheel Alignment

TOYOTA (Cont.)

All Other Models — If angles are not within specifications, adjust by turning nuts on lower arm. If caster angle is too large, increase distance between staked nut and lower arm. If caster angle is too small, decrease distance between staked nut and lower arm. If caster or camber cannot be adjusted to specifications, inspect and repair or replace front suspension components as necessary.

NOTE — Always loosen strut bracket side nut first.

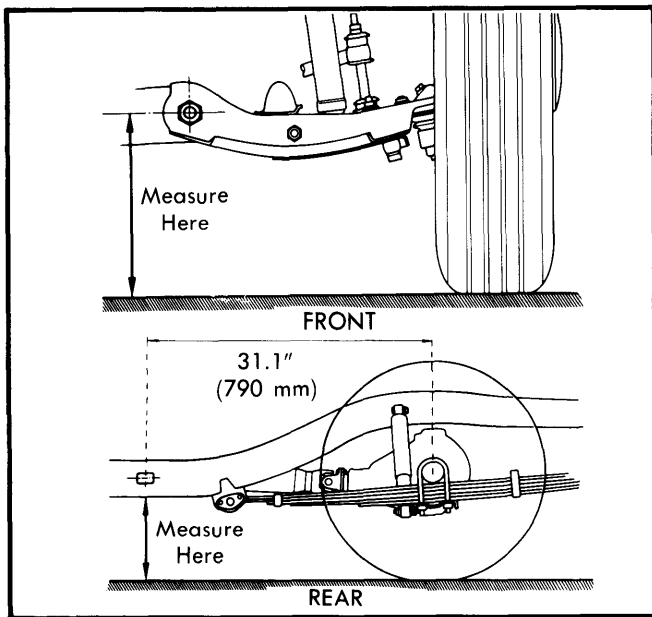

Fig. 2 Riding Height Measurement Points for 2-WD Pickup Models

TOE-IN

All Models — If toe-in is not within specifications, loosen steering link (tie-rod) clamping bolts and rotate adjusting sleeves an equal amount until correct toe-in is obtained. Position clamp bolts at right angles to slot in tie rod and tighten bolts.

RIDING HEIGHT

Before adjusting wheel alignment, check riding height. Riding height must be checked with vehicle on level surface. Bounce vehicle several times and allow suspension to settle. Check riding height as shown in Fig. 1 or Fig. 2. If riding height is not within specifications listed in Riding Height Specifications table, check and repair or replace suspension components.

Riding Height Specifications^①

Application	Front In. (mm)	Rear In. (mm)
Celica & Supra		
165SR14	9.21 (234)	9.25 (235)
175SR14	9.41 (239)	9.45 (240)
185/70 SR14	9.33 (237)	9.37 (238)
Corolla		
Station Wagon		
165SR13	9.13 (232)	9.13 (232)
All Others		
6.45-13	9.33 (237)	9.49 (241)
165SR13	9.06 (230)	9.21 (234)
185/70 SR13	9.13 (232)	9.29 (236)
185/70 HR13	9.13 (232)	9.29 (236)
Corona		
Station Wagon		
5.60-13	9.1 (231)	8.9 (225)
6.45-13	9.0 (229)	8.8 (223)
165SR13	8.8 (223)	8.54 (217)
165SR14	9.25 (235)	9.0 (229)
175SR14	9.49 (241)	9.25 (235)
All Others		
5.60-13	9.1 (231)	9.2 (233)
6.45-13	9.0 (229)	9.1 (231)
165SR13	8.8 (223)	8.9 (225)
165SR14	9.25 (235)	9.33 (237)
175SR14	9.49 (241)	9.6 (243)
Cressida		
Station Wagon		
(All Tires)	7.68 (195)	9.06 (230)
Pickup (2-WD)		
1/2 Ton		
7.00-14 6PR	10.29 (261.4)	11.35 (288.3)
185SR14 4PR	9.83 (249.6)	10.65 (270.4)
E78-14(B)	10.02 (254.4)	11.08 (281.3)
ER78-14(B)	9.87 (250.6)	10.67 (271.0)
3/4 Ton		
7.50-14 6PR	10.96 (278.4)	12.02 (305.3)
Tercel		
155-13 &		
6.15-13 4PR	8.82 (224)	10.47 (266)
155SR12	8.19 (208)	9.84 (250)
165/70 SR13	8.54 (217)	10.20 (259)

① — According to tire size.

TRIUMPH

ADJUSTMENT

TIRE INFLATION (COLD)

Before attempting to check or adjust wheel alignment, make sure tires are properly inflated. Refer to manufacturer's specifications given in owner's manual.

CASTER

All Models — Caster angle is not adjustable. If caster angle is not to specifications, inspect suspension system for wear or damage and repair or replace components as necessary.

CAMBER

Spitfire — Before adjusting camber angle, inspect suspension for wear or damage and repair or replace components as necessary. To adjust, raise vehicle and support chassis on jack stands. Loosen nuts securing lower control arm bracket to chassis. Add shims equally to front and rear of bracket to decrease camber or remove shims equally to increase camber. After each adjustment is made, tighten bracket-to-chassis bolts, remove jack stands and measure camber angle.

TR7 & TR8 — Camber angle is not adjustable. If camber angle is not within specifications, inspect suspension system for

TRIUMPH (Cont.)

wear or damage and repair or replace components as necessary.

TOE-IN

All Models (Front) — Set front wheels in straight ahead position. If adjustment is necessary, loosen steering link (tie rod) lock nuts and gaiter clips. Rotate adjusting sleeves equal

amounts until correct toe-in is obtained. Tighten lock nuts and recheck toe-in.

Spitfire (Rear) — If toe-in is not to specifications, loosen bolts holding strut front support. Adjust as necessary by adding to or removing from the shims fitted between support and body. Tighten bolts and recheck toe-in.

VOLKSWAGEN

ADJUSTMENT

TIRE INFLATION (COLD)

Before attempting to check or adjust wheel alignment, make sure tires are properly inflated. Refer to manufacturer's specifications given in owner's manual.

CASTER

Vanagon — If caster is not within specifications, adjust by changing length of strut bar at crossmember mount. After adjusting caster, check and adjust camber.

All Others — Caster angle is not adjustable. If not within specifications, inspect front suspension for wear or damage and repair or replace components as necessary.

CAMBER

Dasher (Front) — If camber is not within specifications, loosen nuts attaching ball joint to track control arm. To adjust, insert adjusting tool (40-200) in adjusting holes in control arm and pry ball joint sideways until camber is set to specifications. Tighten attaching nuts and recheck camber. Camber should not vary more than 1° between right and left sides.

NOTE — Insert tool from front on right side and from rear on left side.

Vanagon (Front) — If camber is not within specifications, loosen nut on upper control arm shaft and rotate shaft until camber angle is set to specifications. Tighten nut and recheck camber.

Vanagon (Rear) — If camber is not within specifications, loosen outer bolt on trailing arm and adjust camber by using a screwdriver to move trailing arm up or down. Tighten trailing arm bolt and recheck camber.

All Other Models (Front) — If camber is not within specifications, loosen nuts of suspension strut-to-wheel bearing housing mounting bolts. Turn eccentric bolt (upper mounting bolt) until specified camber angle is obtained. Tighten mounting bolt nuts and recheck camber.

All Other Models (Rear) — Rear camber is not adjustable. If camber angle is not within specifications, inspect rear suspension for wear or damage and repair or replace components as necessary.

TOE-IN

Vanagon (Front) — Place wheels in straight-ahead position and ensure lug on rubber washer of pinion shaft is aligned with notch in steering gear housing. Loosen lock nuts and rotate both tie rods equal amounts until toe-in specifications are obtained. Tighten lock nuts, ensure steering wheel is centered on steering shaft and that dust boots are not twisted.

Vanagon (Rear) — If toe-in is not to specifications, loosen inner bolt on trailing arm. Using a screwdriver, adjust toe-in by moving trailing arm forward or rearward until correct toe-in specification is obtained. Tighten trailing arm inner bolt.

All Other Models (Front) — Place wheels in straight-ahead position. Loosen lock nuts on adjustable tie rod end (if equipped). Hold axle boot to avoid twisting. Adjust tie rod until specified toe-in is obtained. Tighten lock nut and recheck toe-in.

All Other Models (Rear) — Toe-in is not adjustable. If toe-in is not within specifications, inspect rear suspension for wear or damage and repair or replace components as necessary.

VOLVO

ADJUSTMENT

TIRE INFLATION (COLD)

Before attempting to check or adjust wheel alignment, make sure tires are properly inflated. Refer to manufacturer's specifications given in owner's manual.

CASTER

Caster cannot be adjusted. If not within specifications, check front end components for damage.

CAMBER

If camber is not within specifications, loosen nuts at strut assembly upper attachment. Use special tool 5038 (or equivalent) at strut upper attachment to adjust camber. Tighten lock nuts. Recheck camber.

TOE-IN

Place wheels in straight-ahead position and loosen lock nut and rubber dust boot outer clamp. Turn tie rods until toe is within specifications. Make sure length of tie rods does not differ more than .08" (2 mm). Measure difference between groove in tie rod and lock nut.