

PORSCHE

911SC
924
928

DESCRIPTION

Brake system is hydraulically operated using a tandem master cylinder and power brake unit. The 911SC and 928 models are equipped with 4-wheel disc brakes. All other models are equipped with front disc brakes/rear drum brakes (optional 4-wheel disc brakes). All models utilize a dual brake warning light to detect pressure drop in either brake circuit. Warning light will not go out until problem is corrected. Parking brake is cable actuated on rear wheels of all models.

ADJUSTMENT

REAR DRUM BRAKE SHOES

Raise and support vehicle. Release parking brake. Turn adjuster until a slight drag is felt when rotating brake drum. Back off adjuster until drum is just free to rotate.

BRAKE PEDAL TRAVEL & FREE PLAY

Brake Pedal Travel — Pedal travel (measured from pedal pad center to point of brake application) should be 1.19-1.56" (30-40 mm). To adjust pedal travel, loosen operating rod lock nut and rotate rod until correct pedal travel is obtained. Tighten operating rod lock nut.

Free Play — Pedal free play (measured from pedal pad center to floorboard) should be about $\frac{3}{8}$ " (10 mm). To adjust pedal free play, loosen operating rod lock nut and set free play to specification. Check pedal travel and tighten operating rod lock nut.

PARKING BRAKE

Except 924 Models — Raise and support vehicle; remove tire and wheel. Release parking brake lever and push caliper pistons and pads into caliper to allow rotor to turn freely. Loosen parking brake cable lock nuts until cable is slack. Working through access hole in parking brake drum, turn star wheel adjuster until rotor cannot be turned by hand. Adjust parking brake cable at rear cable end until it just begins to pull and tighten lock nuts. Back off star wheel adjuster until rotor turns freely without drag. Repeat operation on opposite wheel and check parking brake operation.

924 Models — Raise and support vehicle; ensure service brakes are properly adjusted. From inside vehicle, pull parking brake lever up 2 notches and turn adjuster nut at base of brake lever until both wheels can just be turned by hand.

BRAKE WARNING LIGHT

NOTE — Warning light will glow after any repair on service brake system and will not go out until manually reset.

A dual warning light is mounted on instrument panel. Parking brake light should glow when parking brake lever is pulled 1 notch (ignition on) and go off when lever is fully released. To check circuit warning sensor, fully release parking brake and

ensure light is off (ignition on). Open 1 bleed screw and depress brake pedal; light should glow. To reset warning light, bleed hydraulic system and test service brakes. Disconnect and reconnect negative battery cable; warning lamp should go out.

REMOVAL & INSTALLATION

DISC PADS

NOTE — Mark pads and calipers before removal. If pads are to be reused, they must be installed in original position. If only 1 pad (front or rear) needs replacing, all pads on same axle must be replaced.

Removal — Raise and support vehicle; remove tire and wheel. Disconnect pad wear indicator electrical connection, if equipped. Remove retaining pin clip and retaining pins. On 911SC, squeeze spreader spring and remove disc pads. On all other models, remove inside brake pad with pad remover. Outside disc pad is guided by a tab on sliding caliper frame; remove outer pad by pushing frame out away from rotor and removing pad.

CAUTION — If fluid level is too high in reservoir, overflow will result when pistons (during installation) are pushed back into calipers.

Installation — Push piston back into caliper using suitable tool (P83), or wooden block. Remove anti-rotation locks (if equipped) and clean all parts with alcohol. Inspect all parts for damage or wear. Ensure piston 20° position is correct using suitable gauge (P84). Install remaining parts in reverse order of removal, replace parts as necessary.

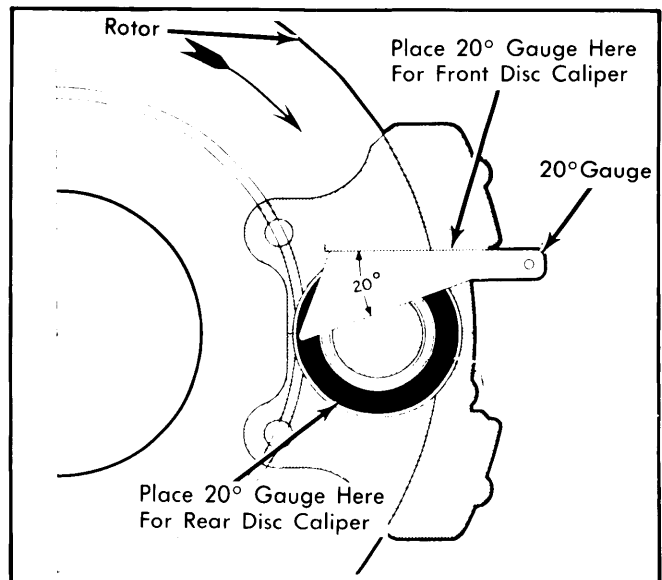

Fig. 1 Positioning Caliper Piston Using 20° Gauge

BRAKE CALIPER

CAUTION — When any fluid fitting is disconnected, fluid will drain from reservoir through master cylinder and out open fitting. To avoid this, depress brake pedal far enough so piston cup will pass the compensating (resupply) port.

PORSCHE (Cont.)

Removal — Raise and support vehicle; remove tire and wheel. Remove brake pads as previously described and remove splash shield (if equipped). Disconnect and plug hydraulic line, remove caliper mounting bolts and remove caliper.

Installation — To install, reverse removal procedure and bleed hydraulic system.

BRAKE ROTOR

Removal — Raise and support vehicle; remove tire and wheel. Remove caliper as previously described and hang from frame with wire; DO NOT disconnect hydraulic line. On front brake rotors, remove dust cap, loosen clamp lock screw, then remove clamp nut and thrust washer. Remove rotor and wheel bearings as an assembly and separate. On rear brake rotors, remove rotor attaching bolts and remove rotor. Mark rotor and hub for reassembly reference, remove hub-to-rotor bolts (if equipped) and separate hub from rotor.

NOTE — If rear rotor cannot be removed by hand, insert two 8 mm bolts into attaching screw holes and alternately tighten bolts to press rotor from hub.

Installation — To install, reverse removal procedure, bleed hydraulic system and adjust front wheel bearings. See *Wheel Bearing Adjustment* in WHEEL ALIGNMENT Section.

NOTE — Rotors must be installed in original position due to cooling holes and internal ventilation channels. These holes and channels are different for right and left sides.

REAR BRAKE SHOES

Removal — Raise and support vehicle and remove wheels. Using suitable puller (40-107) remove brake drum. Remove shoe hold down springs. Remove upper and lower return springs and pressure rod. Remove parking brake rod from brake shoe, stalling parking brake rod.

Installation — Reverse removal procedures and note the following: Lubricate adjusting screws and sliding surfaces of brake shoes lightly. Use new bearing pin and clip when installing parking brake lever.

PARKING BRAKE SHOES (REAR DISC BRAKE ONLY)

Removal — Raise and support vehicle; remove tire and wheel. Remove parking brake drum retaining screws and remove parking brake drum. Remove parking brake cable from shoes. Remove expander, shoe retaining springs and pins, then raise upper shoe and remove adjuster and spring. Remove lower shoe retainer and remove parking brake shoes.

Installation — To install, reverse removal procedure.

MASTER CYLINDER

Removal — On 911SC, raise and support vehicle and drain fluid from reservoir. Pull back on accelerator pedal to detach pedal from pad. Remove floor mat and floor board and withdraw boot from master cylinder. Remove underpanel covering front axle. On all models, remove hydraulic lines, electrical connections and reservoir tubes (if equipped). Remove mounting nuts and remove master cylinder.

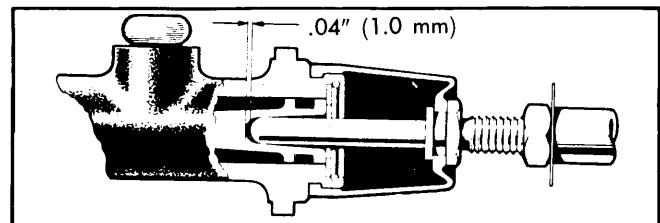

Fig. 3 Illustrating Push Rod-to-Master Cylinder Piston Clearance on 911SC Models

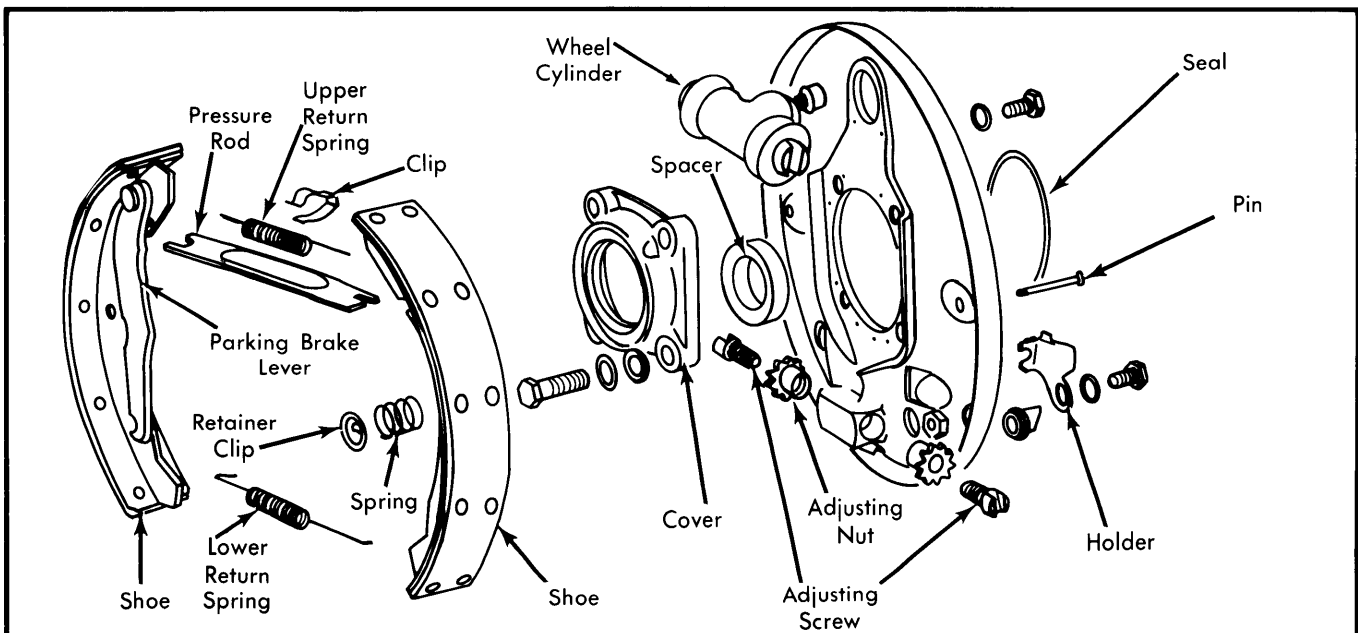

Fig. 2 Exploded View of 924 Rear Brake Assembly

PORSCHE (Cont.)

Installation — To install, reverse removal procedure and note the following: On 911SC, be sure push rod is correctly installed and that clearance between push rod and piston is about .04" (1.0 mm). Use a sealing material on cylinder flange to prevent water leakage into driver's compartment. Bleed hydraulic system.

POWER BRAKE UNIT

NOTE — Before removal, test check valve and power brake unit for operation. To check valve, pull off vacuum hose, place finger over check valve and crank engine; vacuum should be created. To check power brake unit, push on brake pedal several times with engine stopped, hold pedal down and start engine. If power brake unit is operating properly, brake pedal will drop slightly.

Removal — With master cylinder removed, disconnect vacuum hose from power brake unit. Remove pin connecting power brake unit operating rod to brake pedal assembly, remove nuts and remove power brake unit from vehicle.

Installation — Reverse removal procedures and note the following: Apply suitable sealer to power brake unit mounting surface and vacuum line connections. Adjust pedal height and bleed hydraulic system.

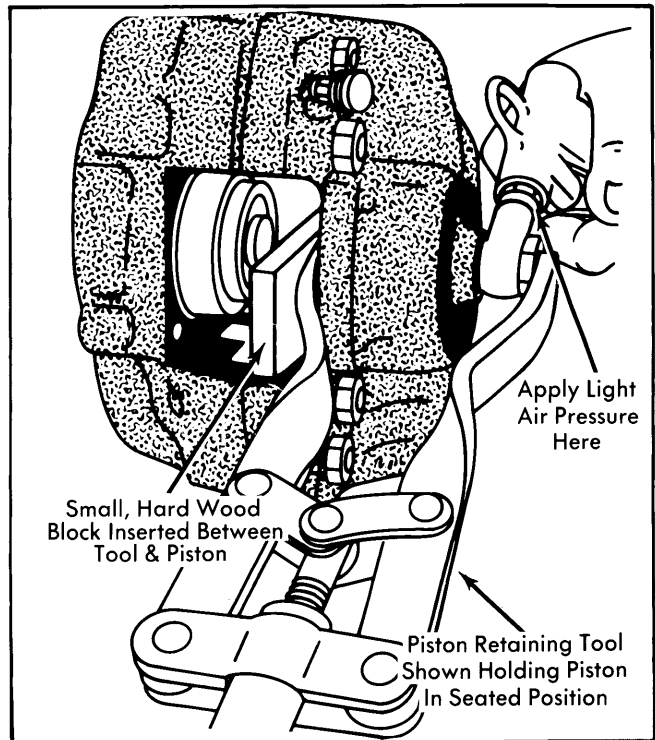

Fig. 4 Using Air Pressure to Remove 911SC Caliper Piston

OVERHAUL**BRAKE CALIPER**

NOTE — Cylinders can only be overhauled one at a time. With 1 piston removed, air pressure cannot be used to remove other piston.

Disassembly (911SC) — Clamp caliper (by mounting flange) in vise. Remove dust boot retaining ring and dust boot. Install piston retaining tool (P83) to 1 piston and place thin wooden block between tool and piston to be removed. Apply light air pressure to fluid inlet hole to remove piston. Remove piston seal from cylinder groove without damaging bore or groove. Repeat procedure for opposite piston after reassembly of first piston.

Separating Caliper Halves — Caliper halves should only be separated if "O" ring seals between caliper halves show signs of leaking. To separate, remove bolts attaching caliper halves, separate caliper and discard "O" ring seals. To reassemble, install new "O" ring seals and reassemble caliper using new bolts, spring washers and nuts.

NOTE — Install shorter bolts in outside holes. Tighten 2 inside bolts first and then tighten outside bolts. Bolts must be tightened in 2 stages; first to 50% of torque value and finally to 100% of torque value.

Cleaning & Inspection — Clean all parts in alcohol or clean brake fluid. Check all parts for wear or damage and replace as necessary. If caliper piston or bore show any signs of wear or damage, complete caliper assembly must be replaced.

Reassembly — Reverse disassembly procedure and note the following: Use new rubber components, dust cover retaining ring and pad retaining plates. Apply brake cylinder paste to piston and cylinder seal. Assure piston is straight with cylinder by using a suitable piston installing clamp. Check 20° position of piston with suitable gauge and correct using piston rotating pliers (if needed). Replace fluid inlet bolt and adapter seals.

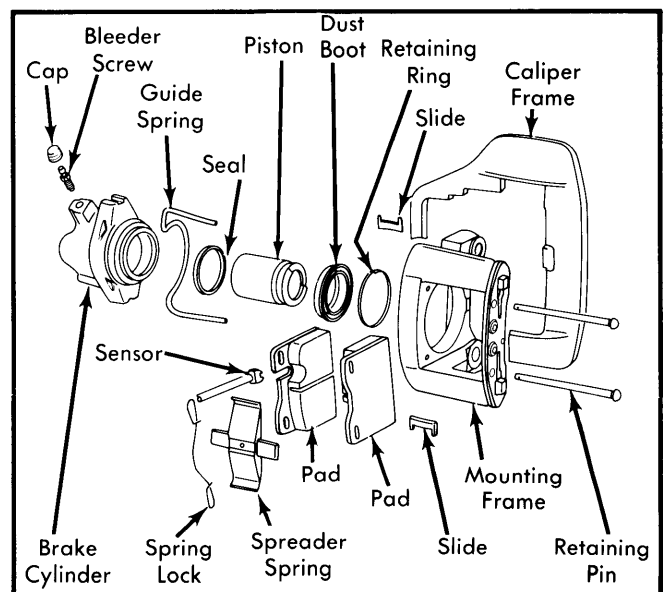

Fig. 5 Exploded View of 924 and 928 Brake Caliper Assembly

PORSCHE (Cont.)

Disassembly (Except 911SC) — With disc pads removed, press caliper frame off mounting frame. Insert wooden block in caliper frame and force cylinder assembly off caliper frame with plastic hammer. Remove dust boot retaining ring and dust boot. Force piston out of caliper bore with light air pressure. Remove piston seal from cylinder groove without damaging groove or bore.

Cleaning & Inspection — Clean all parts in alcohol or clean brake fluid. Check all parts for wear or damage and replace as necessary. If caliper piston or bore show any signs of wear or damage, complete caliper assembly must be replaced.

Reassembly — To reassemble, reverse disassembly procedure and note the following: Use new rubber components, dust cover retaining ring and pad retaining plates. Apply brake cylinder paste to piston and cylinder seal. Assure piston is straight with cylinder by using piston installing clamp. Check 20° position.

master cylinder, and using compressed air, remove pistons and springs.

Cleaning & Inspection — Clean all parts with alcohol. Check all pistons and cylinders for out-of-round, corrosion or damage. Inspect all other parts for scoring, excessive wear, corrosion or other damage.

Reassembly — To reassemble, reverse disassembly procedure and note the following: Lightly coat all parts with brake cylinder paste before installation. Use new "O" ring seals on warning system sending unit and retaining bolt. Tighten all hydraulic lines and fittings. Bleed hydraulic system.

MASTER CYLINDER

Disassembly — Push in on primary piston to remove lock ring, then remove stop plate and primary piston assembly. Remove piston stop screw and, using compressed air, remove secondary piston. Remove secondary piston support washer, spring seat and return spring. To remove hydraulic warning system assembly, remove sending unit and retaining bolt from

POWER BRAKE UNIT

Manufacturer does not recommend overhaul of power brake unit. Replace as complete assembly if defective.

TIGHTENING SPECIFICATIONS

| Application | Ft. Lbs. |
|--|----------|
| Caliper Mounting Bolts | |
| 911SC | 50 (7.0) |
| 924 | 60 (8.3) |
| 928 | 61 (8.4) |
| Caliper Housing Bolts (911SC, Front) | 43 (6.0) |
| Rotor-to-Hub Bolts | 17 (2.4) |

DRUM BRAKE SPECIFICATIONS

| Application | Wheel Cyl. Bore Diameter In. (mm) | Drum Diameter In. (mm) | Original Diameter In. (mm) | Maximum Refinish Diameter In. (mm) | Discard Diameter In. (mm) |
|-------------|-----------------------------------|------------------------|----------------------------|------------------------------------|---------------------------|
| 924 Rear | .750 (19.05) | 9.05 (230) | 9.05 (230) | 9.09 (231) | 9.11 (231.5) |

DISC BRAKE SPECIFICATIONS

| Application | Caliper Bore Diameter In. (mm) | Lateral Runout In. (mm) | Parallelism In. (mm) | Original Thickness In. (mm) | Minimum Refinish Thickness In. (mm) | Discard Thickness In. (mm) |
|-------------|--------------------------------|-------------------------|----------------------|-----------------------------|-------------------------------------|----------------------------|
| 911SC Front | | .008 (.2) | .0012 (.03) | 1.26 (32) | 1.20 (30.6) | 1.18 (30) |
| 911SC Rear | | .008 (.2) | .0012 (.03) | 1.10 (28) | 1.05 (26.6) | 1.02 (26) |
| 924 Front | 1.89 (48) | | | .512 (13) | .472 (12) | .453 (11.5) |
| 928 Front | 2.126 (54) | .004 (.1) | .0012 (.03) | .787 (20) | .732 (18.6) | .709 (18) |
| 928 Rear | 1.417 (36) | .004 (.1) | .0012 (.03) | .787 (20) | .732 (18.6) | .709 (18) |