

## MERCEDES-BENZ

240D  
280 Series  
300 Series  
450 Series

## DESCRIPTION

Service brake system utilizes 4-wheel disc brakes, hydraulically operated by a step-type or tandem master cylinder, connected to a power unit. Step-type master cylinder can be identified by a stop screw located on top center of master cylinder. Tandem master cylinder stop screw is located at bottom center of master cylinder. Cylinders are manufactured by Teves or Bendix and incorporate a 2 or 3-chamber reservoir with a fluid level sensor contact built into each chamber. Warning light is activated when fluid level is low. Parking brakes are cable actuated, internal expanding shoe-type, housed in rear brake rotors.

## ADJUSTMENT

## PEDAL HEIGHT &amp; FREE PLAY

Pedal height (measured from pedal pad to pedal stop) should be 5.9" (150 mm). To adjust pedal height, loosen lock nuts and turn stop light switch until correct height is obtained. Tighten lock nuts. Pedal free play should be .2-.6" (5-15 mm).

## STOP LIGHT SWITCH

Stop light switch is located under dash, above brake pedal. To adjust, loosen lock nuts and adjust switch so that contact button extends .24-.32" (6-8 mm). Tighten lock nuts.

## PARKING BRAKE

Remove one wheel lug bolt at each rear wheel. Raise and support vehicle, and rotate wheels until lug bolt hole is positioned over parking brake adjuster (approximately 45° in upward and forward direction from wheel center). Using a screwdriver inserted through lug bolt hole, turn adjuster until wheel cannot be turned by hand. Back off adjuster until wheel can be turned by hand without restriction.

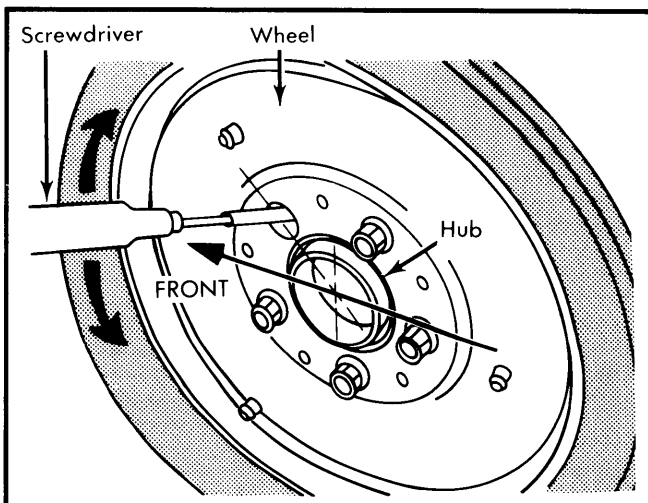

Fig. 1 Fitting Parking Brake Adjuster Tool Into Adjusting Mechanism

## BRAKE WARNING LIGHT

A dual warning light is mounted on dash. Light should glow when parking brake lever is pulled 1 notch and go off when lever is fully released (ignition on). To check circuit warning sensor, release parking brake (ignition on) and ensure light is off. Open bleed screw on 1 wheel and depress brake pedal; light should glow. Close bleed screw, replenish brake fluid and bleed hydraulic system.

## REMOVAL &amp; INSTALLATION

## DISC PADS

**Removal** — Raise vehicle, support with safety stands and remove wheels. If equipped, remove shaft cover plate from caliper and disconnect wear indicator wires. Drive out retaining pins toward inside of vehicle (on Bendix brakes, retaining pins have locking keys in pins) and remove cross spring. Loosen bleed fitting using suitable extractor tool, remove disc pads from caliper assembly.

**NOTE** — All bolts are self-locking hex-head and should be used once only.

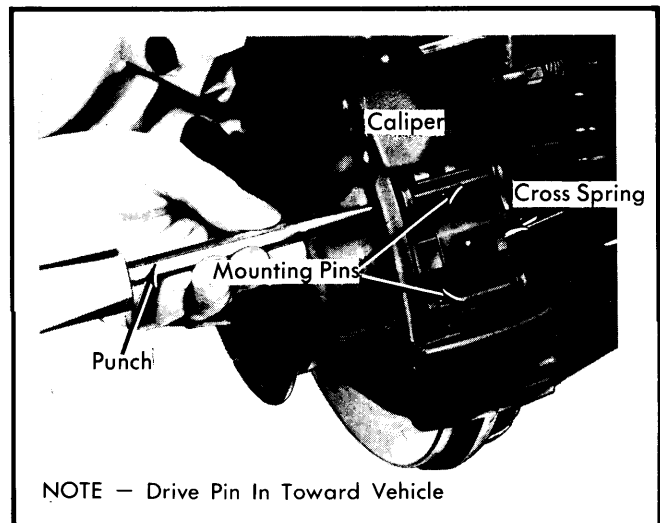

Fig. 2 Knocking Out Disc Pad Mounting Pins On Teves Model Brakes

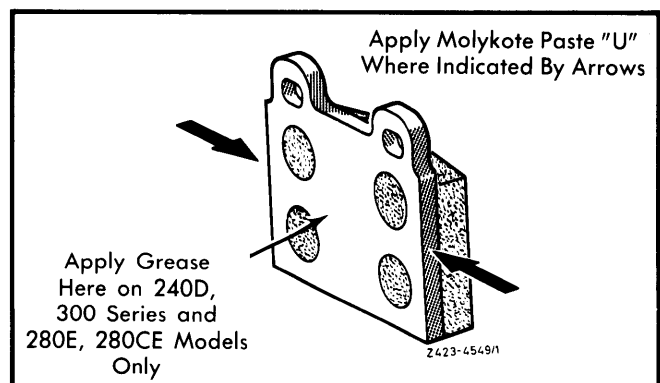

Fig. 3 Typical Mercedes-Benz Disc Brake Pad Illustration Shows Molykote Application Points

## MERCEDES-BENZ (Cont.)

**Installation** — Using a cylinder brush, clean disc pad guide surface in caliper. Siphon sufficient fluid from master cylinder reservoir to prevent overflowing, then press pistons to bottom of bores. Install disc pads, cross spring and retaining pins. If equipped, install cover plate, retaining pin locking keys and wear sensor wires.

### BRAKE CALIPER

**Removal** — Raise and support vehicle, and remove wheel. Disconnect brake lines at caliper assembly, and plug lines to prevent entry of foreign matter. Remove caliper attaching bolts, and remove caliper assembly from vehicle.

**Installation** — Reverse removal procedure ensuring that calipers are replaced in matched pairs from either manufacturer. Tighten all nuts and bolts and bleed hydraulic system.

### BRAKE ROTOR

**Removal & Installation (Front)** — With caliper assembly removed, remove hub grease cap. Remove contact spring for radio shielding, loosen socket screw on clamping nut on wheel spindle, remove clamping nut and washer, then remove wheel hub and rotor assembly. Remove Allen head bolts securing rotor to hub and remove rotor. To install, reverse removal procedure, tighten all bolts and fittings evenly, and bleed hydraulic system if necessary. Adjust front wheel bearing. See *Wheel Bearing Adjustment* in **WHEEL ALIGNMENT** Section.

**Removal & Installation (Rear)** — Remove rear wheel and caliper assembly, then pull rotor out from axle shaft flange. To install, reverse removal procedure, tighten all bolts and fittings evenly, and bleed hydraulic system if necessary.

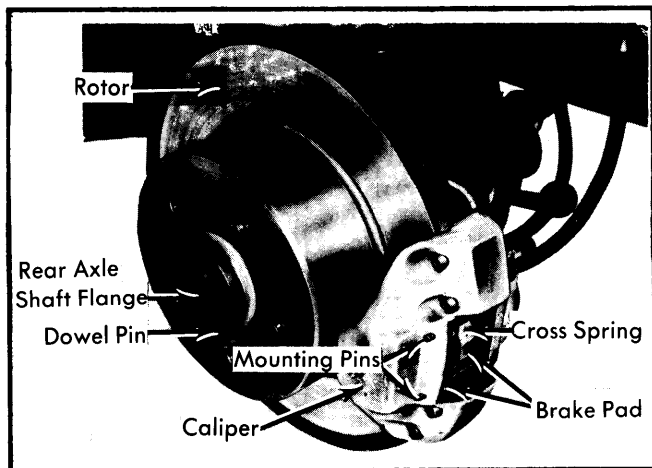

Fig. 4 Assembled View of Rear Hub and Caliper

### MASTER CYLINDER

**Removal** — Drain master cylinder brake fluid. Disconnect and plug brake lines, disconnect electrical wires. Remove bolts securing master cylinder to power booster and remove master cylinder.

**Installation** — Reverse removal procedure and note the following: Always replace rubber "O" ring seal between master cylinder and power unit. Bleed hydraulic system and check complete system for fluid leaks.

### POWER BRAKE UNIT

**Removal** — Drain master cylinder and remove master cylinder from vehicle. Disconnect vacuum line at power brake unit and disconnect push rod at brake pedal. Remove power brake unit attaching hardware and remove assembly from vehicle.

**Installation** — To install, reverse removal procedure, tighten all nuts and bolts, and bleed hydraulic system.

## OVERHAUL

### BRAKE CALIPER

**Disassembly** — With caliper removed from vehicle and disc pads removed from caliper, remove dust cap from piston housing. Hold one piston in place using a suitable clamp, then apply compressed air to fluid inlet and remove opposite piston. Remove piston seal from groove of cylinder bore. Remove remaining piston and seal in same manner.

**NOTE** — DO NOT separate caliper halves.

**CAUTION** — DO NOT polish chrome plated surfaces of pistons.

**Cleaning & Inspection** — Remove deposits on pistons with a soft brass wire brush. Check cylinder bore of caliper for wear or damage. Small rust deposits may be removed with polishing cloth. Heavier deposits in front of piston seal groove may be removed with fine emery cloth.

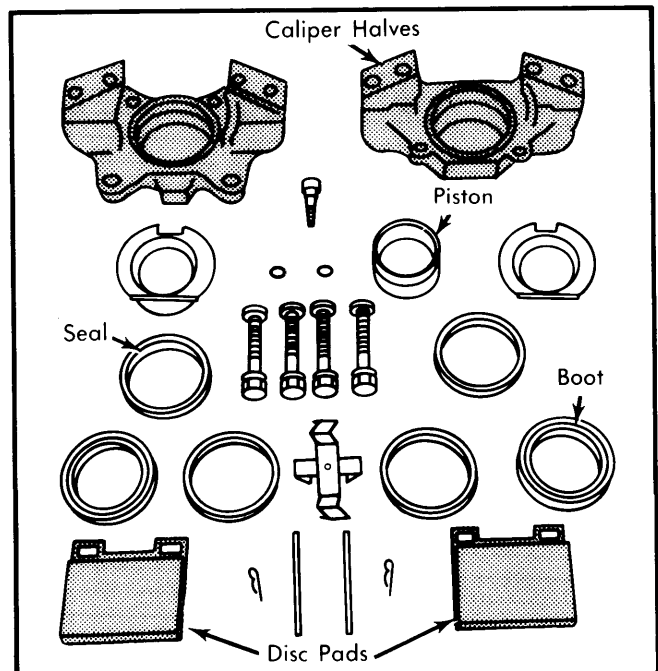

Fig. 5 Disassembled View of Typical Mercedes-Benz Brake Caliper

**Reassembly** — Coat piston and caliper bore with ATE brake cylinder paste (or equivalent), install piston seal into caliper bore and install piston. Install dust cap, then install heat shield into piston with recess in shield fitting into elevation of piston.

**NOTE** — Elevation on piston MUST face downward and project at least .004" (.1 mm) above shield.

## MERCEDES-BENZ (Cont.)

### MASTER CYLINDER

**CAUTION** — Bendix master cylinder, spray painted blue, cannot be repaired.

**Disassembly (Tandem and Step Tandem)** — Remove reservoir, push piston in with screwdriver, then remove stop screw and "O" ring. Remove lock ring from housing, then remove piston, stop washer, 2 vacuum seals and intermediate ring. Remove intermediate piston by rapping lightly with a wooden board.

**NOTE** — Teves reservoir only, remove cap, end covers, strainer, splash guard, "O" rings and contact inserts. Bendix model, remove strainer from cover. DO NOT remove contact inserts. All models, master cylinder diameter should be .937" (23.81 mm).

**Inspection** — Clean all parts with alcohol or brake fluid. Check bore in housing and piston for scoring and rust. Small rust spots in housing may be removed with polishing cloth. Scored or badly rusted parts cannot be repaired, replace complete master cylinder.

**Reassembly** — Reverse disassembly procedure and bleed hydraulic system.

### TIGHTENING SPECIFICATIONS

Application	Ft. Lbs. (mkg)
Caliper Mounting Bolts	
Front .....	83 (11.5)
Rear .....	65 (9.0)
Hub-to-Rotor Bolts .....	83 (11.5)

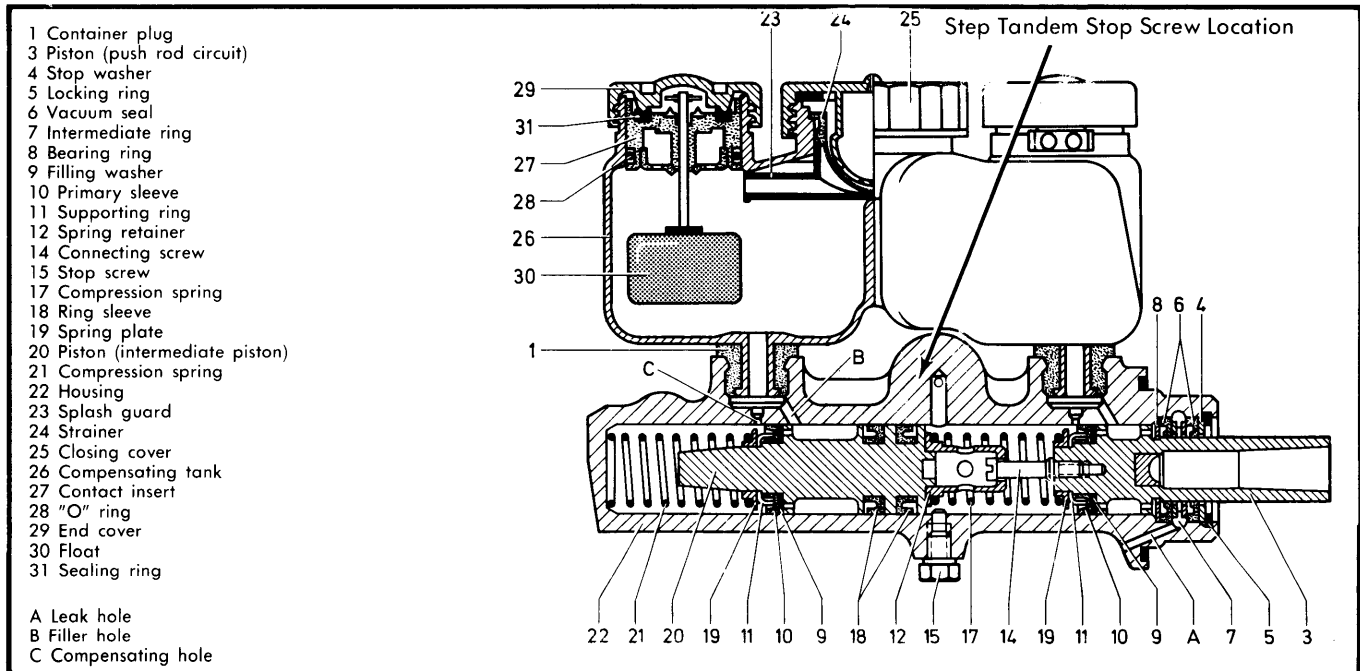

Fig. 6 Sectional View of Late Model Mercedes-Benz Tandem Master Cylinder

### DISC BRAKE SPECIFICATIONS

Application	Caliper Bore Diameter In. (mm)	Lateral Runout In. (mm)	Parallelism In. (mm)	Original Thickness In. (mm)	Minimum Refinish Thickness In. (mm)	Discard Thickness In. (mm)
240D, 280E, 280CE, 300 Series						
Front	2.36 (60)	.005 (.12)	.0008 (.02)	.496 (12.6)	.....	.417 (10.6)
Rear	1.50 <sup>Ⓞ</sup> (38)	.005 (.12)	.0008 (.02)	.394 (10)	.....	.327 (8.3)
280SE & 450 Series						
Front	2.36 (60)	.005 (.12)	.0008 (.02)	.866 (22)	.....	.787 (20)
Rear	1.50 (38)	.005 (.12)	.0008 (.02)	.394 (10)	.....	.327 (8.3)

Ⓞ — 300TD Caliper bore diameter — 1.65" (.42 mm).