

## FIAT

Brava  
Spider 2000  
Strada  
X1/9

### DESCRIPTION

Brake system is hydraulically operated, using a tandem master cylinder and vacuum power brake unit. Spider 2000 and X1/9 models use single piston, sliding caliper, 4-wheel disc brakes. All other models are equipped with single piston, floating caliper front disc and leading/trailing rear drum brakes. All front and rear brake applications are self-adjusting. All models except X1/9 use pressure differential valves in rear brake circuits. All parking brakes are cable actuated and operate on rear brake application.

### ADJUSTMENT

#### PARKING BRAKE

Pump service brakes several times to seat pistons, then fully release parking brake lever. Pull parking brake lever up 3-4 notches (3 notches on Brava and Strada). On Spider 2000 and X1/9 models, tighten nut on equalizer until rear wheels lock. X1/9 models have an opening provided in floor pan under body for access to equalizer. On Brava and Strada models, loosen lock nut located under parking brake handle and tighten adjusting nut until rear wheels lock. On all models, release parking brake and ensure rear wheels rotate freely. Repeat adjustment procedure if rear wheels drag.

#### BRAKE WARNING LIGHT

A dual warning light is mounted on dash. Light should glow when parking brake lever is pulled 1 notch and go off when lever is fully released (ignition on). To check circuit warning, release parking brake (ignition on) and ensure light is off. Lift master cylinder reservoir cover until level indicator is above fluid level; light should glow.

#### BRAKE PRESSURE REGULATOR

**Brava** — Install regulator and leave mounting bolts loose. Bring torsion bar (7) to dimension shown in Fig. 1 from base of buffer end (11). Remove rubber boot (3) from regulator, then rotate regulator until piston (6) is just touching torsion bar (1). Tighten mounting bolts.

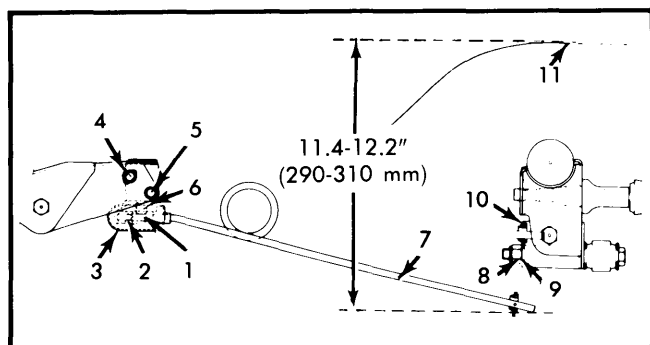

**Fig. 1 Brake Pressure Regulator Measurement and Adjustment Points for Brava Models**

**Spider 2000** — 1) Bring end of torsion bar (E) to distance shown in Fig. 2 from buffer resting surface. Use a jack to raise body to gain appropriate height, or place weight in passenger seat before tightening.

2) Lift dust boot (C) and check contact of regulator piston (D) with torsion bar end (E).

3) Pivot regulator body on screw (A) until piston (D) is just touching torsion bar end (E).

4) First, tighten screw (B) and then screw (A) in all the way. Connect link (G) to torsion bar eye end (E) with screw and nut while inserting rubber bushings and spacer.

**NOTE** — Fluid inlet from master cylinder must be connected to lower union (R) and fluid line to rear brakes must be connected to upper union (S).

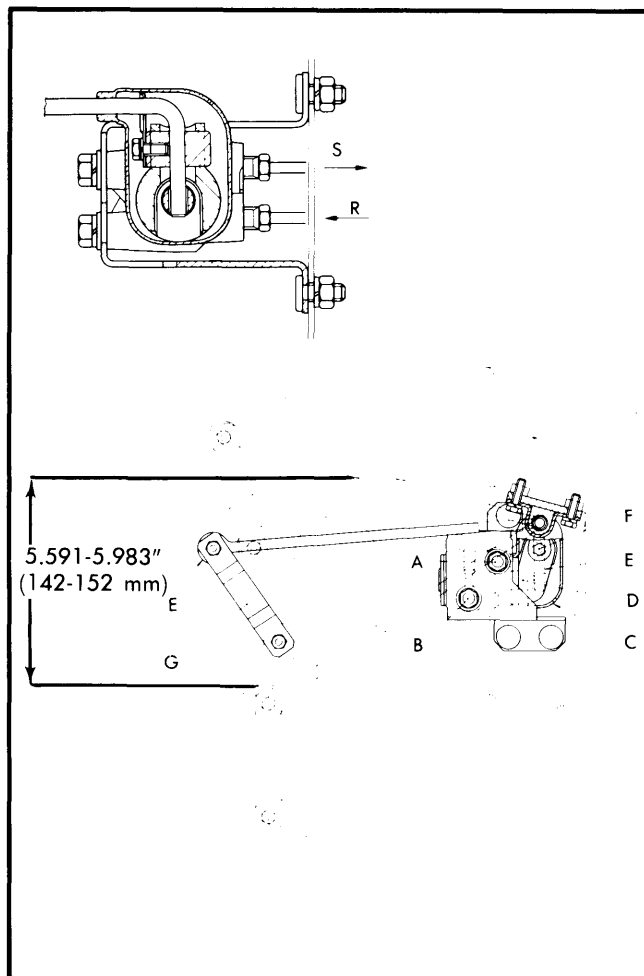
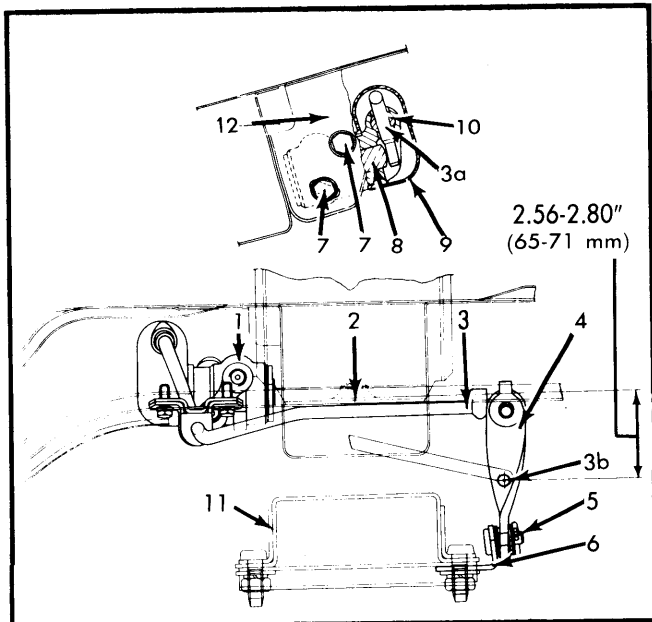

**Fig. 2 Brake Pressure Regulator Measurement and Adjustment Points for Spider 2000**

**Strada** — Raise and support vehicle. Loosen compensator (1) attaching bolts (7). Unclip plastic clamp and slide dust boot (9) from compensator. Disconnect torsion bar (3) from connecting link (4). Distance between center of suspension rubber buffer seat (2) and torsion bar end (3b) must be as shown in Fig. 3. Once specification is obtained, rotate compensator until piston (8) is just touching torsion bar (3a). Tighten bolts, connect torsion bar to connecting link. Slide dust boot onto compensator and secure with plastic clamp.

**NOTE** — Vehicle must not be loaded if drive-on type lift is used to support vehicle.

## FIAT (Cont.)



**Fig. 3 Brake Pressure Regulator Measurement and Adjustment Points for Strada Models**

## REMOVAL &amp; INSTALLATION

## DISC BRAKE CALIPERS &amp; PADS

**Removal** — Raise and support vehicle; remove wheels. Plug master cylinder outlet ports. Disconnect brake line from caliper assembly. Remove cotter pins from locking blocks, drive out locking blocks and remove caliper. Take out disc pads and springs. On models with rear disc brakes, parking brake must be disconnected.

**NOTE** — Pads **MUST** be replaced when worn to .079" (2 mm) from original thickness.

**Installation** — To install caliper and pad assemblies, reverse removal procedure and note the following: Inside and outside pads may be different. When fitting pads to calipers, ensure distance between inner surfaces is not less than .413" (10.5 mm). In most instances two kinds of pads are available, be sure index paint stripes are not mixed.

## BRAKE ROTOR

**Removal** — Remove caliper as previously outlined. Mount a dial indicator so plunger is .08" (2 mm) from outer edge of rotor and record runout. Remove caliper support bracket from support plate (front) or from axle housing (rear). Remove bolts mounting rotor to hub. Remove hub plate (if equipped), then using a puller or drift, remove rotor from hub.

**Installation** — Fit rotor onto wheel hub, install attaching bolts and tighten evenly.

## REAR BRAKE DRUM

**Removal** — Raise and support vehicle; remove tire and wheel. Remove locating pin and attaching bolt. Remove brake drum, releasing shoe adjustment, if required.

**Installation** — To install, reverse removal procedure.

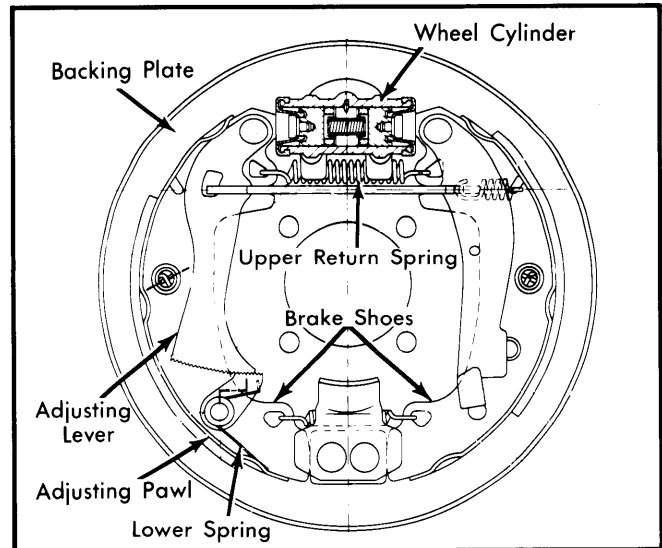

**Fig. 4 Brava Rear Drum Brake Assembly**

## REAR BRAKE SHOES

**Removal** — 1) Raise and support vehicle; remove tire and wheel. Remove brake drum. Retain wheel cylinder pistons in position with a clamp. Remove upper and lower return springs, shoe guide pins, springs and cups.

2) Disconnect parking brake cable from brake shoe link and remove brake shoes. Place brake shoes on work bench and remove self-adjusting lever by removing retaining clip on back of brake shoe. Remove adjusting pawl by removing spring retainer and spring, then remove adjusting pawl.

**Installation** — To install, reverse removal procedure and note the following: Longer return spring is upper return spring. Install brake shoes with ends correctly positioned in wheel cylinder pistons.

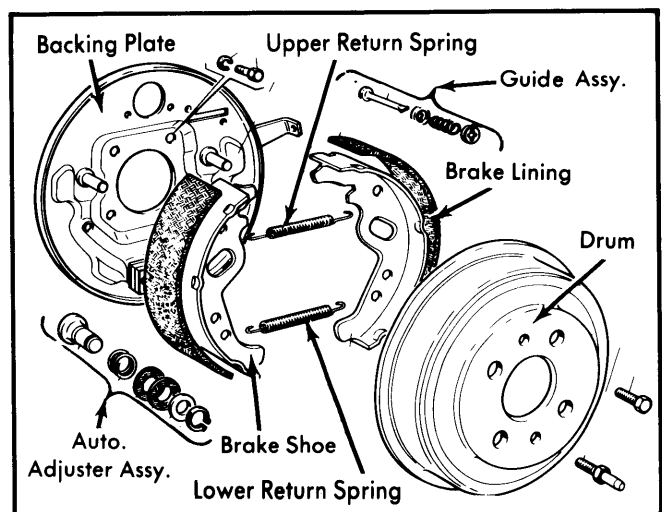

**Fig. 5 Strada Rear Drum Brake Assembly**

## MASTER CYLINDER

**Removal (X1/9)** — Remove steering column. See *Steering Column Removal* in **STEERING** Section. Disconnect hydraulic lines from reservoir. Remove mounting nuts and slide unit off supports. Disconnect outlet lines from master cylinder.

## FIAT (Cont.)

**Installation** — To install, reverse removal procedure and bleed hydraulic system.

**Removal (All Others)** — Remove jack and spare tire from engine compartment (if equipped), then remove spare tire support. While holding brake fluid level sensor, unscrew reservoir cover and remove assembly. Siphon fluid from reservoir. Gently rock reservoir from side to side and remove. Disconnect and plug hydraulic lines. Remove mounting nuts and remove master cylinder from power brake unit.

**Installation** — To install, reverse removal procedure and bleed hydraulic system.

### POWER BRAKE UNIT

**Removal** — Remove master cylinder as previously outlined. Loosen vacuum hose clamp and remove vacuum hose from power brake unit. Remove cotter pin, lock nut and washer from operating rod clevis at brake pedal. Remove brake unit mounting nuts and remove power brake unit.

**Installation** — To install, reverse removal procedure and note the following: After installing master cylinder, bleed hydraulic system.

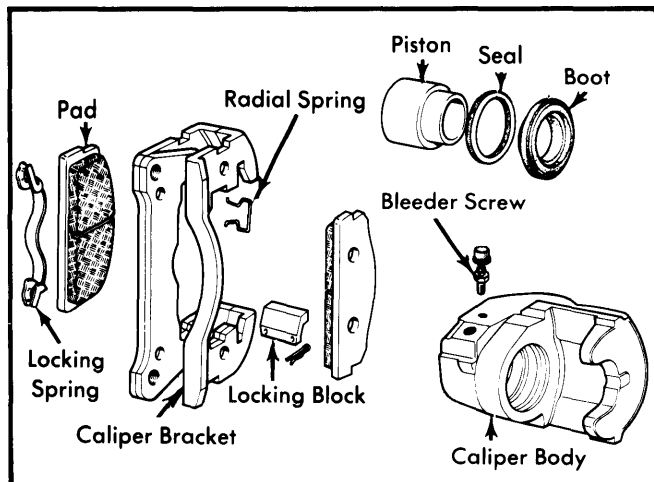

**Fig. 6 Exploded View of Front Brake Caliper for All Models Except X1/9**

### OVERHAUL

#### BRAKE CALIPERS

**Disassembly (Front)** — With caliper assembly on bench, remove dust boot. Apply light air pressure to brake fluid inlet union and gently force piston from caliper. Remove piston seal from groove in cylinder bore.

**NOTE** — Be sure bore is not scratched during removal process.

**Cleaning & Inspection** — Clean all components in suitable solvent (Fiat LDC). Inspect each part for damage or excessive wear. Replace all piston seals and dust boots.

**Reassembly** — Fit piston seal in caliper. Insert piston to bottom end of cylinder bore. Position dust boot on caliper body. Fit caliper body into caliper bracket and reinstall on vehicle.

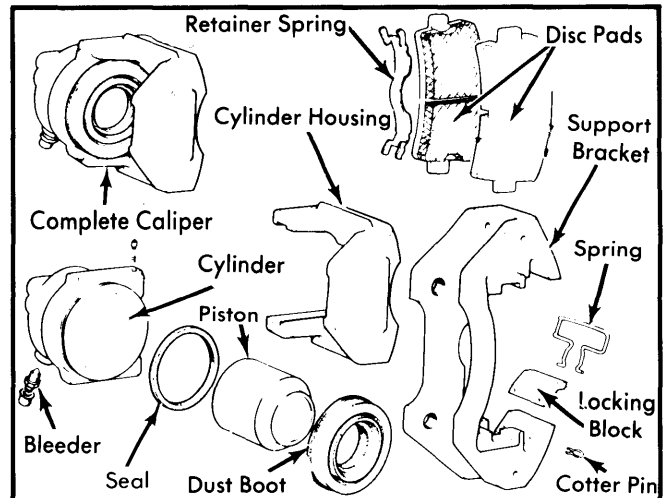
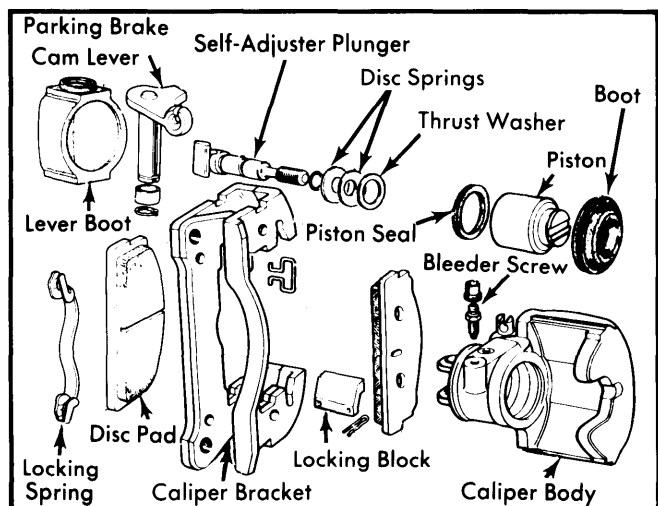

**Fig. 7 Exploded View of Front Brake Caliper for X1/9**

**Disassembly (Rear)** — With caliper assembly on bench, remove dust boot. With a screwdriver, separate piston from plunger. Remove piston seal from groove in piston cylinder bore. Remove cam lever, pivot pin, and lever. Lift out self-adjusting plunger, plunger seal, disc spring, and spring thrust washer.

**Cleaning & Inspection** — Clean all components in suitable solvent (Fiat LDC). Inspect each part for damage or excessive wear. Replace all piston seals and dust boots.

**Reassembly** — Fit self-adjusting plunger complete with seal, disc springs, and thrust washer. Fit parking brake cam lever complete with pivot pin. Fit pivot pin bushing and snap ring. Fit piston sealing ring into caliper cylinder. Screw piston into cylinder until fully seated. Align piston slot so it is opposite bleed connection. Refit dust boot.



**Fig. 8 Exploded View of Rear Brake Caliper Spider 2000 Shown - X1/9 Similar**

#### MASTER CYLINDER

**Disassembly** — Remove connector(s) and cylinder bore dust boot. Remove stop bolt(s) and seal(s). Remove set screws and end plug (if equipped). Remove piston assemblies, return springs, cups, seals and spacers.

**Inspection** — Clean and thoroughly dry all parts, then inspect for wear or damage. Light scoring may be removed by hon-

## FIAT (Cont.)

ing, make sure honing does not alter size of cylinder diameter. Replace all rubber pieces each time overhaul is performed.

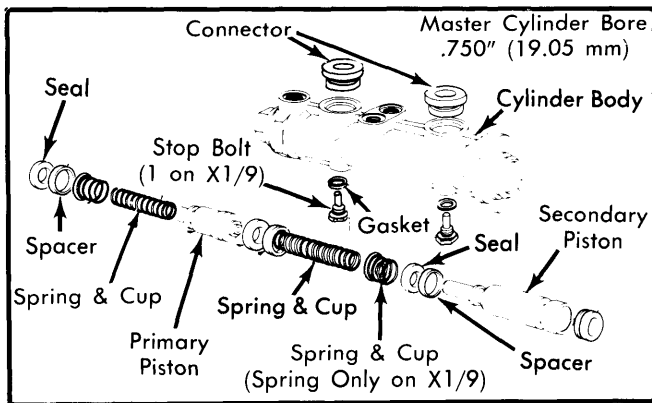

**Fig. 9 Exploded View of Fiat Master Cylinder**

**Reassembly** – To reassemble, reverse disassembly procedure and lightly coat all components with brake fluid before reassembly.

### POWER BRAKE UNIT

**NOTE** – The following procedure is for Strada models; all other models may require variations from the procedure outlined.

**Disassembly** – 1) Remove check valve and grommet from front shell. Place wooden blocks on both master cylinder mounting studs and 4 power brake mounting studs, then place unit in a vise. Slowly tighten vise until rear shell can be rotated clear of front shell locking tabs.

2) Separate front and rear shells. Slowly release vise until spring pressure is released, then remove power brake unit. Remove dust boot from rear shell. Remove filter assembly. Remove key to remove plunger and valve. Separate diaphragm from rear shell. Remove rear seal assembly.

3) Remove guide bushing front seal, vacuum piston, piston rod, backing plate and spring from front shell. DO NOT disturb adjustment of piston rod.

**Inspection** – Manufacturer recommends replacing the following parts during overhaul: Backing plate, front seal, filter assembly and rear seal assembly. Inspect all other parts for wear or damage and replace as required.

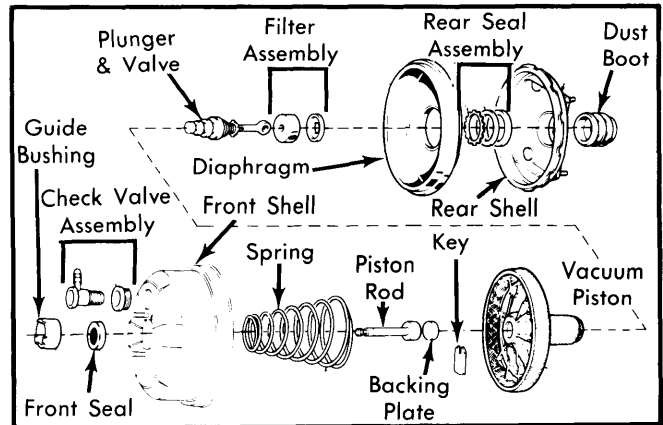

**Fig. 10 Exploded View of Strada Power Brake Unit**

**Reassembly** – To reassemble power brake unit, reverse disassembly procedure and note the following: After reassembly, adjust tip of push rod so it extends past the surface of front cover by .032-.040" (.825-1.025 mm). Adjust by turning nut.

### DISC BRAKE SPECIFICATIONS

Application	Caliper Bore Diameter In. (mm)	Lateral Runout In. (mm)	Parallelism In. (mm)	Original Thickness In. (mm)	Minimum Refinish Thickness In. (mm)	Discard Thickness In. (mm)
Brava	1.89 (48)	.004 (.10)	.....	.425 (10.8)	.....	.386 (9.8)
Spider 2000 & X1/9 Front	1.89 (48)	.006 (.15)	.....	.392-.400 (9.95-10.20)	.368 (9.35)	.354 (9.0)
Rear	1.34 (34)	.006 (.15)	.....	.392-.400 (9.95-10.20)	.368 <sup>Ⓢ</sup> (9.35)	.354 (9.0)
Strada	.....	.10 (.25)	.....	.421-.429 (10.7-10.9)	.368 (9.35)	.354 (9.0)

Ⓢ – Spider 2000 rear is .372" (9.45 mm).

### DRUM BRAKE SPECIFICATIONS

Application	Wheel Cyl. Bore Diameter In. (mm)	Drum Diameter In. (mm)	Original Diameter In. (mm)	Maximum Refinish Diameter In. (mm)	Discard Diameter In. (mm)
Brava	.875 (22.2)	9.00 (228.6)	9.00 (228.6)	9.03 (229.4)	9.055 (230)
Strada	.687 (17.46)	7.30 (185.4)	7.30 (185.4)	7.335 (186.3)	7.355 (186.8)