

AUDI 5000 POWER-ASSISTED RACK & PINION

DESCRIPTION

A power-assisted rack and pinion steering gear is used on Audi 5000 models. The system consists of a vane pump, rotary piston pinion gear assembly and an oil reservoir. The vane pump draws fluid from the reservoir and supplies it to the flow control valve. The control valve supplies fluid to the proper side of the rack-piston as the steering wheel is turned. The pump is belt driven and mounted on the front of the engine. The reservoir is located near the firewall.

GENERAL SERVICE

Capacity — 1 qt.

Lubricant — ATF Dexron or Dexron II

Oil Level Check — Remove reservoir cover, start engine and check fluid level. Fluid level should be at mark on upper inside of reservoir.

Hydraulic System Bleeding — Start engine and allow to idle. Check that fluid is at proper level. Turn steering wheel lock to lock several times quickly. Continue until fluid level remains at reservoir mark. Make sure that no bubbles appear in reservoir when steering wheel is turned. Shut off engine and check that fluid level does not rise more than $\frac{3}{8}$ " (9.5 mm) above mark.

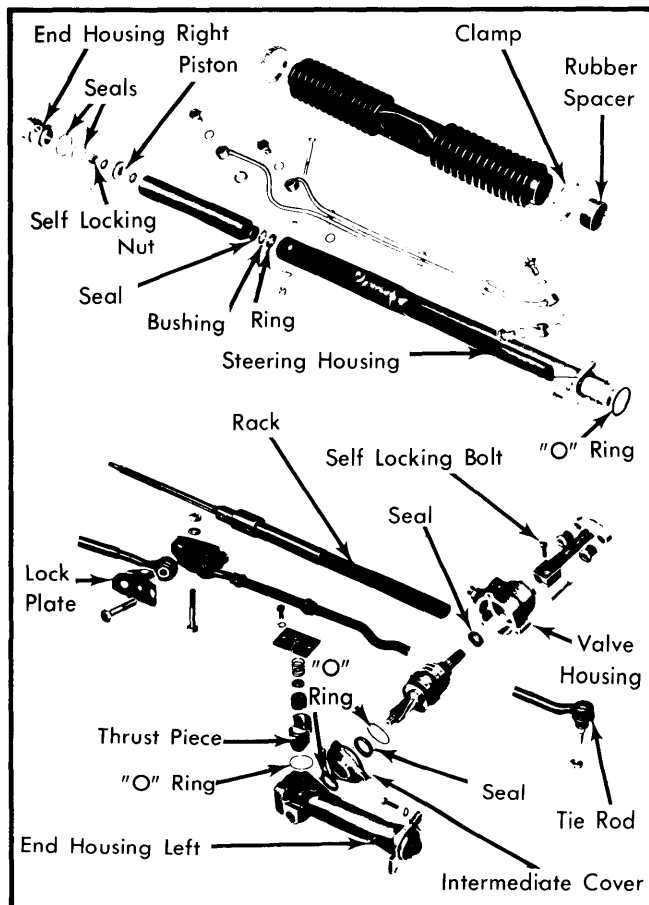

Fig. 1 Exploded View of Audi 5000 Steering Gear Assembly

Oil Filter Replacement — Remove outer cover, gasket and spring from reservoir. Remove inner filter cover and filter insert. Replace filter. Install new filter, replace filter cover, spring, gasket and cover. Check fluid level.

NOTE — Oil filter insert must be replaced whenever repairs are made to power steering system.

ADJUSTMENT

PUMP BELT

Remove "V" belt from alternator and air conditioning compressor. Loosen 2 nuts on pump mounting bracket as shown in Fig. 3. Turn adjusting nut on bracket until belt deflection is $\frac{3}{8}$ " (9.5 mm) at center. Tighten nuts. Reinstall alternator "V" belts.

STEERING GEAR

Loosen lock nut on steering gear. Hand tighten adjusting screw until it touches the thrust plate. Hold adjusting screw and tighten lock nut. Check adjustment with engine idling. No play should be felt. Readjust if necessary.

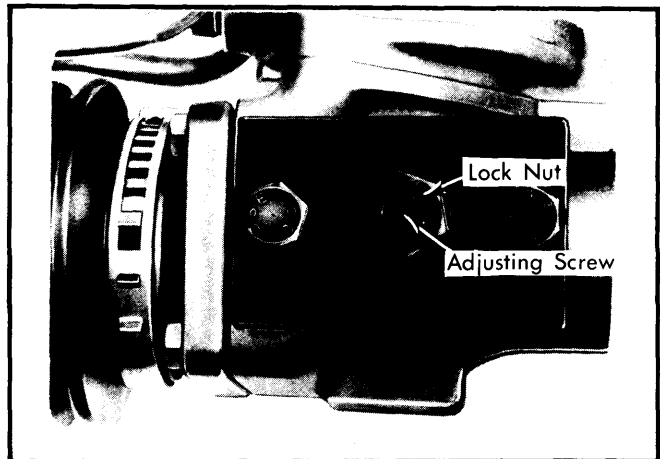

Fig. 2 Steering Gear Adjustment

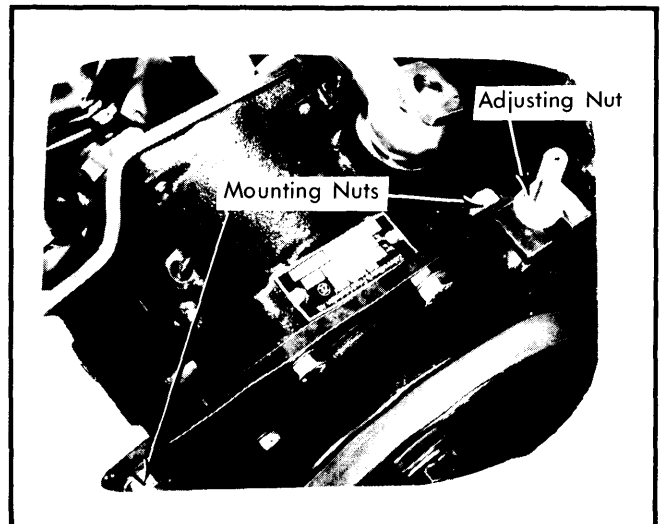

Fig. 3 Power Steering Belt Adjustment

AUDI 5000 POWER-ASSISTED RACK & PINION (Cont.)

TESTING

SYSTEM PRESSURE TEST

Install pressure gauge (US1074) between expansion hose and connecting pipe of valve housing, with valve open. Run engine at idle. Turn steering wheel lock to lock several times. Check pressure. Correct pressure is 967-1166 psi (68-82 kg/cm²). If pressure is not within limits, replace steering gear.

PUMP PRESSURE TEST

1) With pressure gauge installed, start engine and idle. Close valve (no longer than 5 seconds) and check pressure. Correct pressure is 967-1166 psi (68-82 kg/cm²). If pressure differs, check pressure/flow limiting valve. If valve is all right, replace power steering pump.

2) To check limiting valve, inspect bores in valve and piston for obstructions, and that piston moves freely in housing. Install new valve if necessary.

LEAKAGE TEST

With engine idling, turn steering wheel to full lock and hold in position. Inspect all connections and tighten if necessary. If leak shows at steering pinion, replace pinion housing seal and both intermediate cover seals. If piston rod is leaking fluid will have entered steering housing. Check for fluid by loosening outer clamp on right steering boot and pushing boot in. If seal is leaking, disassemble steering gear and replace all seals.

REMOVAL & INSTALLATION

STEERING GEAR

Removal — Drain fluid from system. Disconnect pressure hose and return line. Cap openings. Remove tie rod lock plate and both tie rod mounting bolts. Pry tie rods off steering gear. Disconnect steering damper. Disconnect flange tube clamp from steering gear and remove flange tube. Remove steering gear mounting bolts from body. Turn front wheels to right lock and remove steering gear through opening in right wheel well.

Installation — Reverse removal procedures, noting the following: Replace tie rod lock plate before reinstallation. To facilitate tie rod installation, install one tie rod to steering gear and tighten before installing other tie rod.

VANE PUMP

Removal — Remove alternator "V" belt and vane pump "V" belt. Disconnect pressure and suction lines from pump and cover openings. Remove mounting bolts from bracket and lift pump from engine.

Installation — Reverse removal procedures noting the following: Adjust "V" belt deflection to $\frac{3}{8}$ " at center. After reinstalling pressure and suction lines, start engine and turn steering wheel to full lock and check for leaks in connections.

OVERHAUL

NOTE — Manufacturer does not recommend overhaul of steering gear. Leaking seals may be replaced, however. Check output and system pressure before removing steering gear. Steering gear must be removed to replace seals.

PINION HOUSING SEALS

Disassembly — 1) Remove attaching bolts from valve housing and remove housing. Remove pinion gear and intermediate cover.

2) Remove "O" rings from intermediate cover (one on each side) and, using suitable tool, drive out intermediate cover oil seal. Anchor housing in padded vise and drive out oil seal from the back.

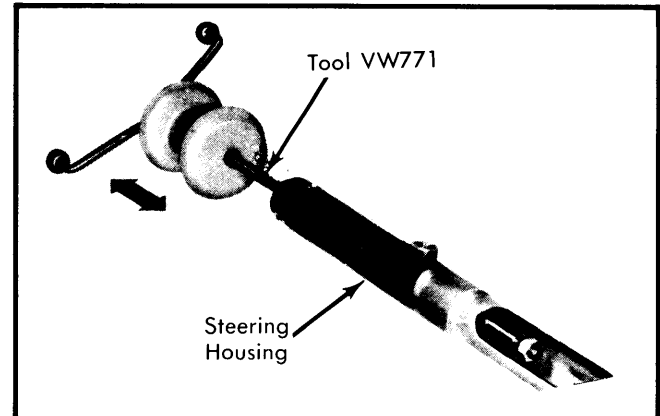

Fig. 4 Steering Housing Oil Seal Removing

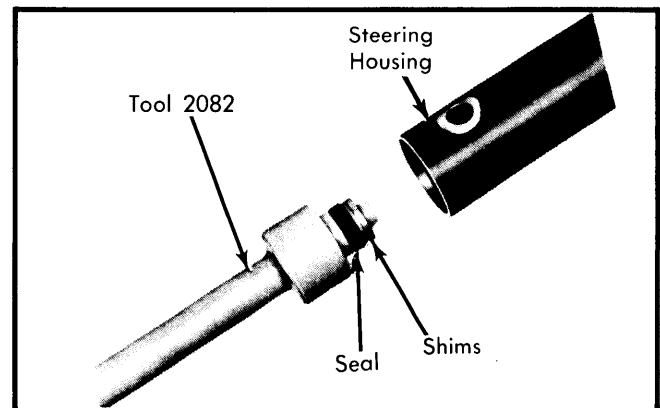

Fig. 5 Steering Housing Oil Seal Installation

3) Install new seals from the inside cover and housing. Make sure that seal lip on housing seal faces intermediate cover, and seal lip of cover seal faces valve housing. Replace both intermediate cover "O" rings.

Reassembly — Reverse removal procedure noting the following: Protect pinion teeth on shaft when replacing intermediate cover. Do not damage "O" rings during reinstallation.

STEERING HOUSING SEALS

Disassembly — With steering gear removed from vehicle, drive out right end of steering housing with drift, remove seals and "O" ring. Clamp rack in vise, remove self locking nut and piston. Insert special tool (VW771) into right steering housing and remove oil seal and shims.

AUDI 5000 POWER-ASSISTED RACK & PINION (Cont.)

Reassembly — Using special tool (2082), install shims and seal with thin shim behind seal, and seal lip facing piston. Replace piston and self locking nut. Tighten to specification. Replace seals, "O" ring, and end housing.

VANE PUMP OIL SEAL

Disassembly — 1) With pump removed from vehicle, remove pulley and woodruff key from pinion shaft. Disengage outer circlip with pliers and screw pulley nut onto pinion shaft.

2) Anchor pulley nut and shaft in padded vise, and strike pump housing with plastic mallet to drive out shaft. Remove from vise and disengage inner circlip with pliers. Insert extractor into housing. Tighten nut on extractor until two jaws on extractor engage on metal case of seal.

3) Anchor nut of extractor in vise and strike pump housing with plastic hammer to drive out seal.

Reassembly — Lubricate space between lips of new seal. Drive seal onto seat with lips facing interior of housing. Install inner circlip. Carefully drive pump shaft onto seat with plastic hammer, watching alignment of pump shaft and impeller splines. Install outer circlip, woodruff key and pulley.

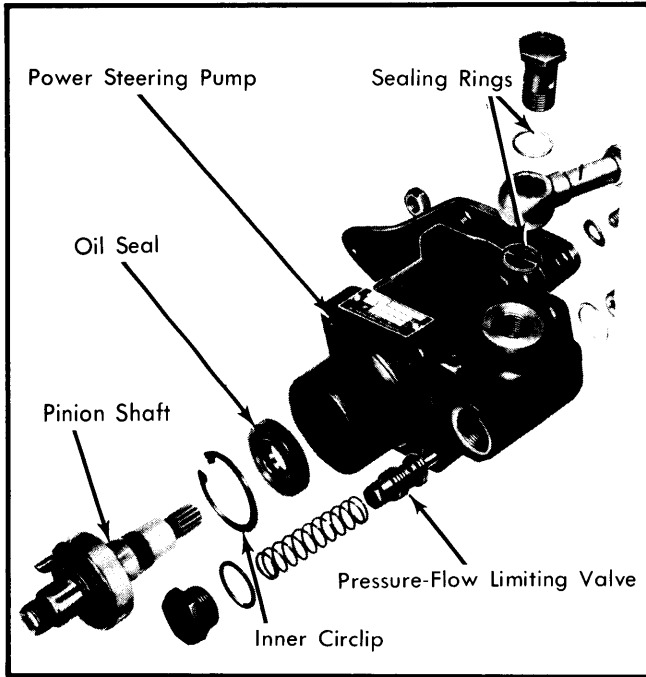

Fig. 6 Exploded View of Power Steering Pump Assembly

TIGHTENING SPECIFICATIONS

Application	Ft. Lbs. (mkg)
Pulley to Pump Shaft	36 (6)
Pump Mounting Bolts	14 (2)
Pinion Shaft Nut	14 (2)
Steering Damper	29 (4)
Tie Rod to Steering Gear	43 (6)
Valve Housing Bolts	7 (1)
Tie Rod Locking Nut	43 (6)
Steering Housing Locking Nut	29 (4)
Expansion Hose	29 (4)
Suction Hose	29 (4)
Flange Tube to Steering Gear	22 (3)

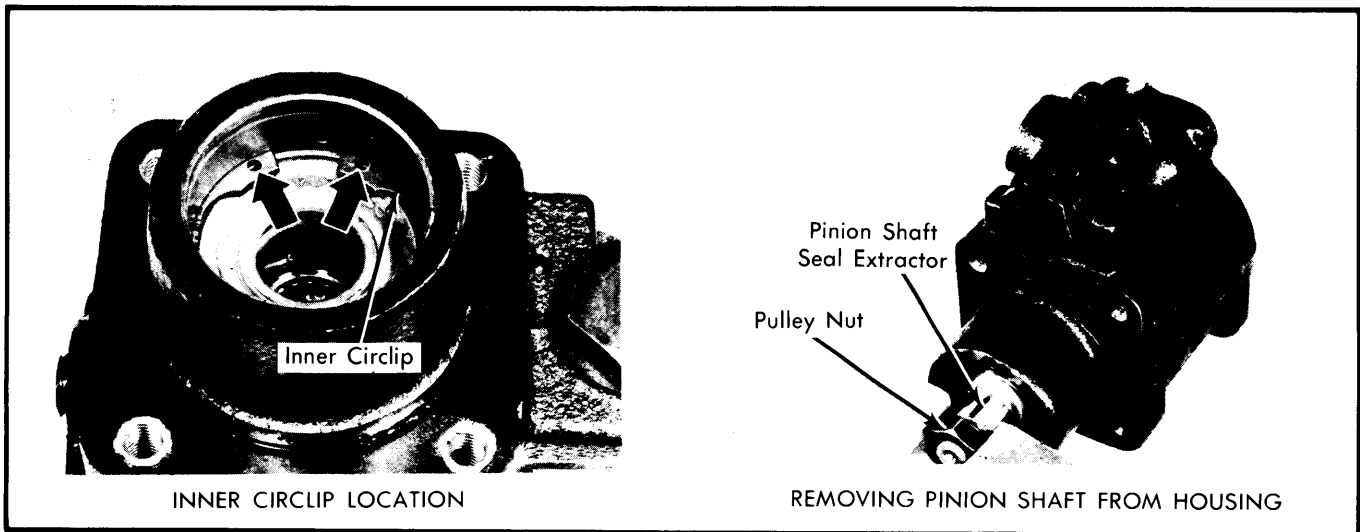

Fig. 7 Vane Pump Oil Seal Removal