

Steering Gears & Linkage

AUDI 4000 RACK & PINION

DESCRIPTION

Steering system is a direct-acting rack and pinion gear mounted to crossmember and connected to tie rods by a bracket. Tie rods are connected to steering knuckle by ball joints.

ADJUSTMENT

RACK ADJUSTMENT

Loosen lock nut on steering gear cover. Hand tighten adjusting screw until it touches thrust washer. Hold screw in position and tighten lock nut. If steering is too tight or does not self center, readjust. If gear rattles when driven, adjustment is too loose.

CAUTION — Do not turn gear hard against either lock when vehicle is raised off ground or damage may result.

REMOVAL & INSTALLATION

STEERING GEAR

Removal — 1) After removing both tie rod mounting bolts from rack, pry tie rods off steering gear. On early models, loosen bottom steering column mounting bolt and pry off clamp. On late models, use a screwdriver to push cap from engine compartment to inside of vehicle, then loosen bottom steering column mounting bolt and pry off clamp. Also remove seal ring.

2) On all models, drive bottom of column off gear using a brass mandrel. Remove gear mounting bolts from body. Turn wheels to right lock and remove steering gear through opening in right wheel well.

Installation — 1) On early models, before installing steering gear in vehicle, install the slider (in which both sealing sleeves are welded into the cup, see Fig. 2).

2) On all models, install steering gear to vehicle. To facilitate installation of tie rods on early models, remove one bolt from slider, install tie rod and reinstall bolt. Repeat procedure for

other tie rod. Install bracket. On late models, install tie rods to tie rod bracket, then install bracket to steering drive pawl. Install steering drive pawl to steering gear rack. Install seal ring. On all models, install clamp and attach column to steering gear. On late models, push cap from inside vehicle to steering gear.

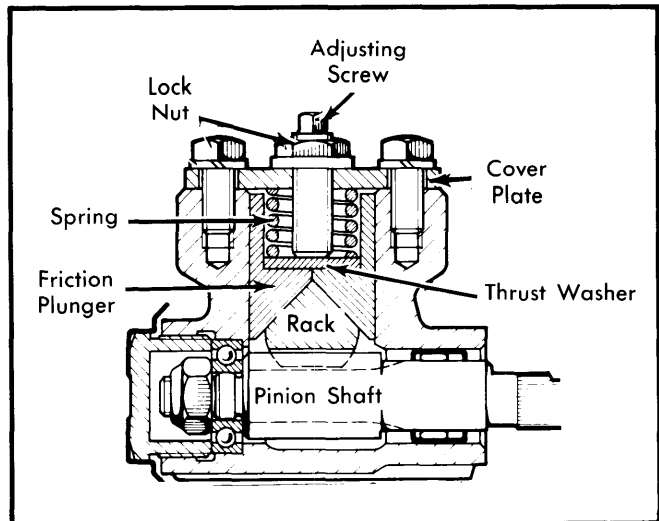

Fig. 1 Cross Sectional View of Pinion Shaft with Rack Adjustment

STEERING DAMPER

NOTE — Replacement of steering damper is the only service procedure recommended. Do not attempt repairs on this unit.

OVERHAUL

NOTE — Manufacturer does not recommend overhaul of this rack and pinion steering unit. If unit is determined defective, replace as assembly.

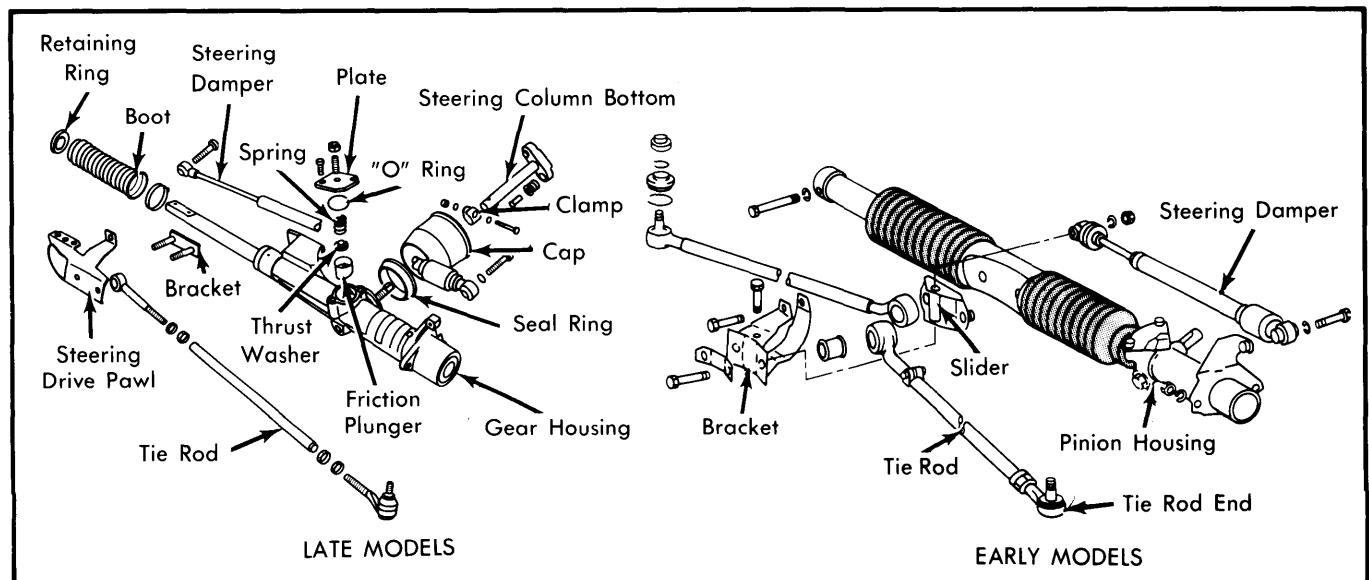

Fig. 2 Exploded View of Audi 4000 Rack and Pinion Assembly (Early and Late Models)