

PEUGEOT

504
505
604

DESCRIPTION

Steering column consists of an upper and lower steering shaft connected by a universal joint. Steering shaft utilizes a rubber flexible coupling at its lower end to help absorb road shocks. Steering column contains the steering lock, turn signal/horn switch, headlight dimmer/washer switch and on some models, the speed control switch.

REMOVAL & INSTALLATION

Removal – 1) Disconnect battery ground cable. Remove bolt connecting steering shaft rubber coupling to gear box. Remove horn pad cover, steering wheel nut and steering wheel. Mark relative position of steering wheel to shaft.

2) Remove steering column trim panels necessary to obtain access to column mounting bolts. Disconnect all switch connectors. Remove column cover to floor pan bolts.

3) Remove lower column retaining bolts, then remove upper column retaining bolts. Pull steering column out from passenger compartment.

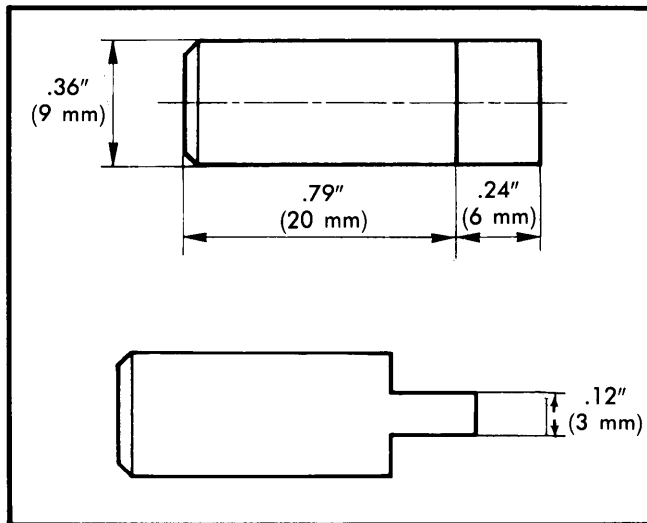

Fig. 1 Dimensions for Fabricating Clearance Gauge
(504 Models Only)

Installation – 1) To install steering column, reverse removal procedures and note the following: Place front wheels in straight ahead position. Install column assembly, from passenger compartment, and align lower shaft with flexible coupling. Tighten column mounting bolts.

2) On 504 models, insert fabricated clearance gauge into recess at flexible coupling and tighten pinch bolt. Remove gauge. On all models, make sure all switches are installed, connected and operate properly. Install column trim covers and steering wheel.

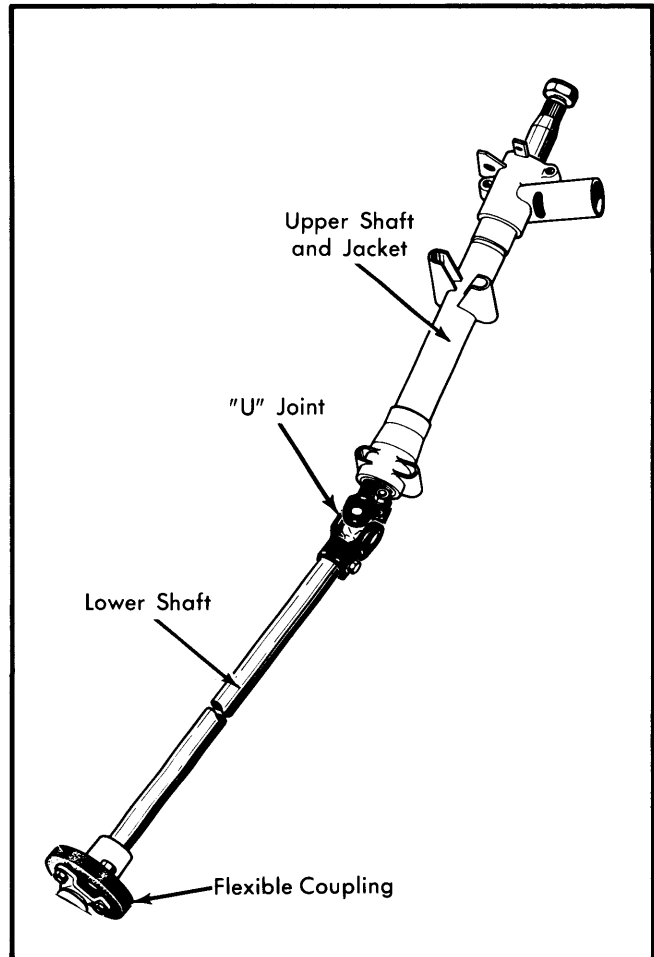

Fig. 2 Peugeot Steering Column Assembly
(504 Shown, 505 and 604 Similar)