

SUBARU

1600
Brat

DESCRIPTION

Rear suspension consists of a control arm, shock absorber and torsion bar as 3 main components of each side. Fig. 1.

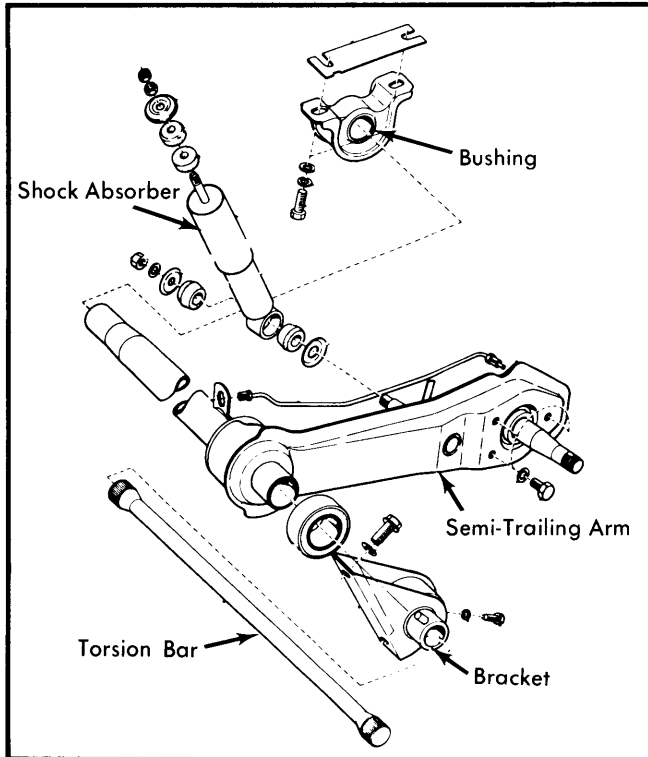

Fig. 1 Subaru Rear Suspension Components (2-Wheel Drive Shown; 4-Wheel Drive Similar)

ADJUSTMENT

WHEEL ALIGNMENT SPECIFICATIONS & PROCEDURES

See *Wheel Alignment Specifications and Procedures* in **WHEEL ALIGNMENT** Section.

REMOVAL & INSTALLATION

REAR SUSPENSION ASSEMBLY

NOTE — To repair or replace any rear suspension components, with the exception of shock absorbers, suspension assembly for side being repaired must be removed.

Removal — 1) Raise rear of vehicle and support with safety stands. Remove rear wheels and disconnect brake line from flex line. Disconnect lower shock absorber mount. Remove bolts securing inner control arm pivot shaft mount to body.

2) Loosen lock bolt at outer bushing. Remove outer control arm pivot shaft mount bolts and remove suspension assembly for one side.

Disassembly — With lock bolt removed, pull outer bracket from bushing and pull torsion bar from control arm. Remove outer bushing with a suitable puller (925210000). Inner bushing can be removed in same manner.

Reassembly — Press bushing onto control arm, making sure bushings are flush with ends of control arm. Apply grease to serrations on end of torsion bar. Torsion bars are marked "R" and "L", they should be installed accordingly. The angle between center line of bushing and control arm should be as specified. See *Chart and Fig. 2*.

Bushing Installed Angle

Application	Degrees
Sedan, Coupe, Hdtop.	6
Station Wagon	7
4-Wheel Drive	16.5

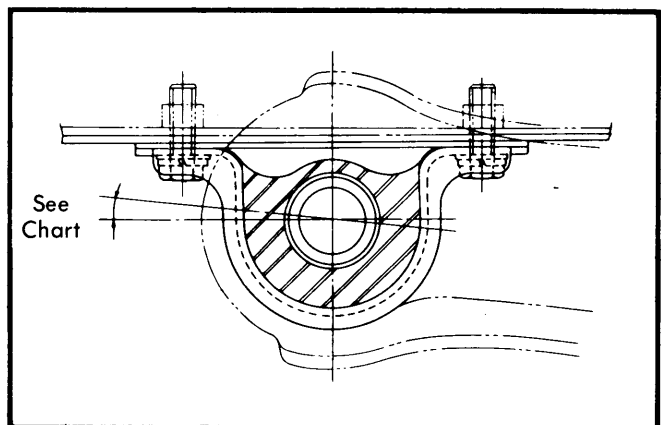

Fig. 2 Measuring Angle Between Centerline of Bushing and Control Arm

Installation — To install suspension assembly, reverse removal procedure and note the following: Bleed brake system and check rear wheel alignment.

TIGHTENING SPECIFICATIONS

Application	Ft. Lbs. (mkg)
Lower Control Arm	
Inner Bushing Bolt	33-38 (4.5-5.3)
Outer Bracket Bolts	87-108 (12.0-15.0)
Outer Bushing Bolt	13-18 (1.8-2.5)
Shock Absorber Lower Nut	22-32 (3.0-4.5)