

Rear Suspension

MERCEDES-BENZ — EXCEPT 6.9

240D
280 Series
300 Series
450 Series

NOTE — For 300TD components not covered in this article, see Automatic Level Control article in this section.

DESCRIPTION

Rear suspension is independent with coil springs and semi-trailing arms. Rear axle carrier is mounted to body at three points and supports rear axle assembly. Axle shafts serve as upper control arms to rear wheels. Wheel hubs are supported by semi-trailing arms which run forward to pivot points on rear axle carrier and body. Shock absorbers are mounted inside of coil springs, attached to body on top and to semi-trailing arms on bottom. Stabilizer bar is mounted to body and to wheel hubs at ends.

ADJUSTMENT

WHEEL ALIGNMENT SPECIFICATIONS & ADJUSTMENTS

See *Wheel Alignment Specifications & Adjustments* in *WHEEL ALIGNMENT* Section.

REMOVAL & INSTALLATION

SHOCK ABSORBERS (EXC. 300TD)

NOTE — Shock absorbers should be removed only when vehicle is on wheels or when semi-trailing arm is supported.

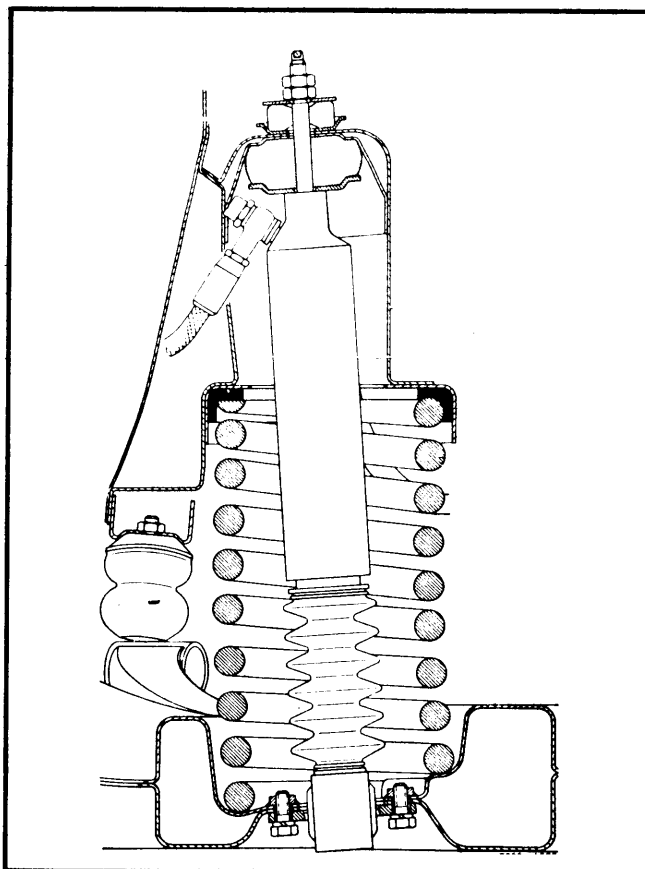

Fig. 1 Rear Spring and Shock Configuration

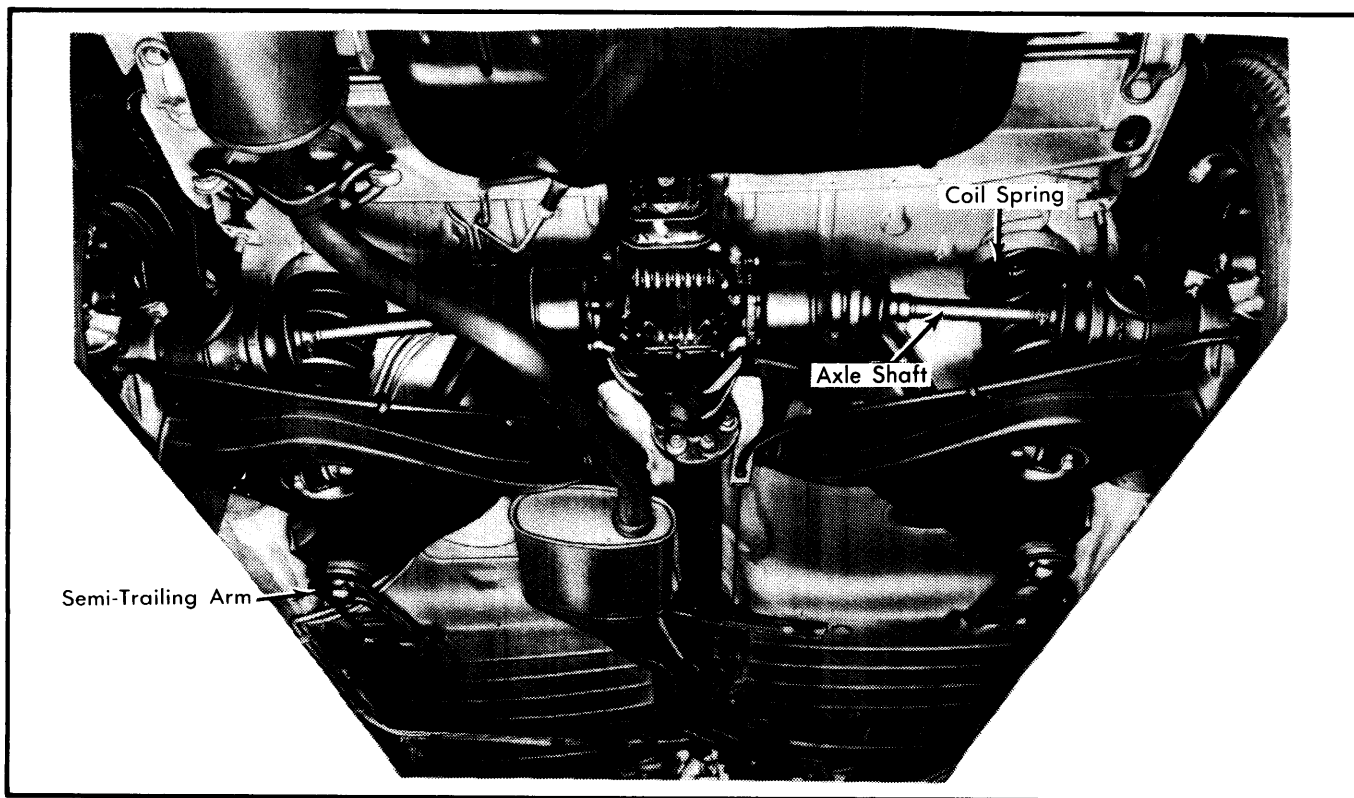

Fig. 2 Rear to Front View of Typical Mercedes Benz Rear Suspension

MERCEDES-BENZ – EXCEPT 6.9 (Cont.)

Removal – On vehicles with coupe top, remove top and open flap. On all models, remove rear seat and backrest. Remove locking lever from top flap and unscrew lining. Remove nut and rubber ring of upper shock mount. Remove lower shock mount on semi-trailing arm. Remove shock absorber in a downward direction.

Installation – To install, reverse removal procedure.

COIL SPRINGS

Removal – Remove shock absorbers as previously outlined. Raise and support rear of vehicle on safety stands. Raise semi-trailing arm until approximately level. Using suitable spring compressor, compress spring. Carefully lower semi-trailing arm and remove spring with rubber mounting.

Installation – To install, reverse removal procedure.

REAR STABILIZER BAR

Removal – Raise and support rear of vehicle with safety stands. Remove wheels. Detach connecting rod from stabilizer

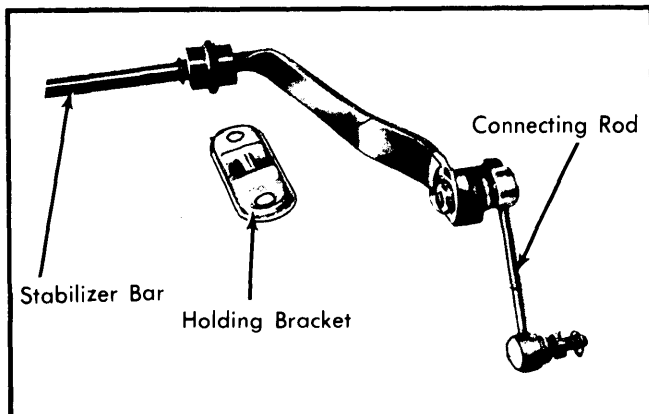

Fig. 3 Stabilizer Bar and Mounting Locations

on both sides of vehicle. Remove stabilizer bar holding brackets. Loosen exhaust pipe mounts (rubber rings) and lower slightly. Remove stabilizer bar in a downward direction.

Installation – To install, reverse removal procedure.

NOTE – When installing rear stabilizer bar, ensure that bend of bar is pointing upward.

REAR SUSPENSION & AXLE

Removal – 1) Raise and support vehicle with safety stands. Remove wheels. Disconnect exhaust system. Detach parking brake control cables at frame and compensating lever.

2) Loosen clamp nut and disconnect drive shaft intermediate bearing from frame. Disconnect rear of drive shaft and slide forward, out of centering position.

NOTE – On 3-piece drive shaft, loosen front clamp nut only.

3) Remove shock absorber and coil spring. Detach and plug brake lines. Disconnect stabilizer bar holding clamps.

4) Place suitable support jack under rear suspension. Disconnect supporting plates and front and rear rubber mounts from frame. Carefully lower jack and remove rear suspension from vehicle. Remove rear rubber mount from axle.

CAUTION – When lowering and removing rear suspension, be sure cover plates of disc brakes are not damaged.

Installation – To install, reverse removal procedure.

DIFFERENTIAL WITH AXLE SHAFTS

Removal – 1) Drain fluid from differential. Detach brake caliper from right rotor and wire out of way. Remove axle shaft-to-flange attaching bolts (both sides) and force rear shafts out of shaft flanges.

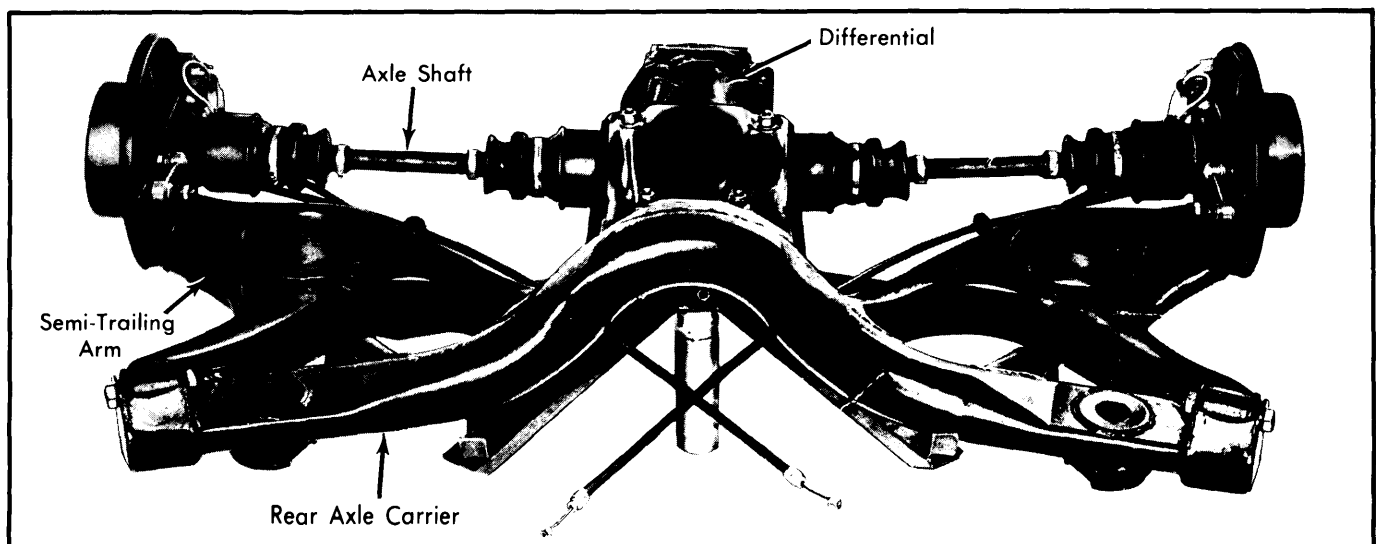

Fig. 4 Typical Mercedes Benz Rear Suspension with Components Removed

Rear Suspension

MERCEDES-BENZ – EXCEPT 6.9 (Cont.)

NOTE – If required, loosen right shock absorber upper mount and lower semi-trailing arm to deflection stop.

2) If required, remove exhaust system. Loosen clamp nut and detach drive shaft intermediate bearing from frame. Remove drive shaft from differential and push from centering alignment.

NOTE – On 3-piece drive shaft, loosen front clamp nut only.

3) Support differential with jack and suitable support (115 589 35 63 00). Disconnect rear rubber mount from body. Disconnect differential from rear axle carrier. Lower jack and remove differential with axle shafts.

CAUTION – When moving differential with axle shafts, make sure that axle shafts are supported and **DO NOT** drop down, as this might damage inner joints.

Installation – Check all rubber parts and replace as necessary. To install differential with rear axle shafts, reverse removal procedure. Tighten down all nuts and bolts, except when connecting drive shaft to differential. These bolts must be torqued after vehicle has been rolled forward and backward to seat parts. Install exhaust system, if removed.

REAR AXLE CARRIER

Removal – Remove rear suspension, differential with rear axle shafts and semi-trailing arms as previously outlined.

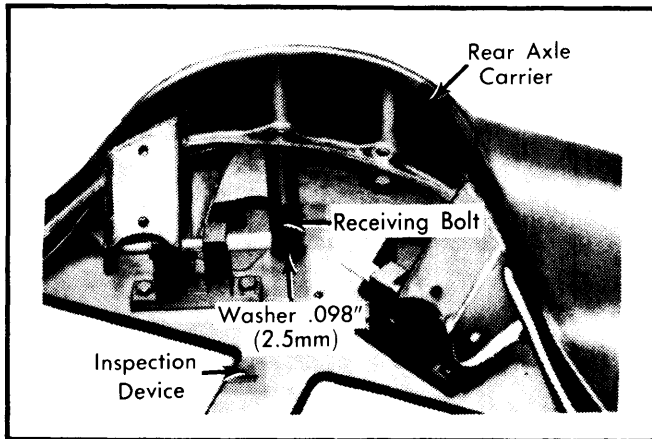

Fig. 5 Proper Washer Placement for Rear Axle Carriers without Spot Welds

Inspection – Using inspection tool (Fig. 6), check rear axle carrier. When checking rear axle carriers without spot welded washers, place a .098" (2.5 mm) thick washer under receiving bolt (Fig 5).

Installation – To install rear axle, reverse removal procedure.

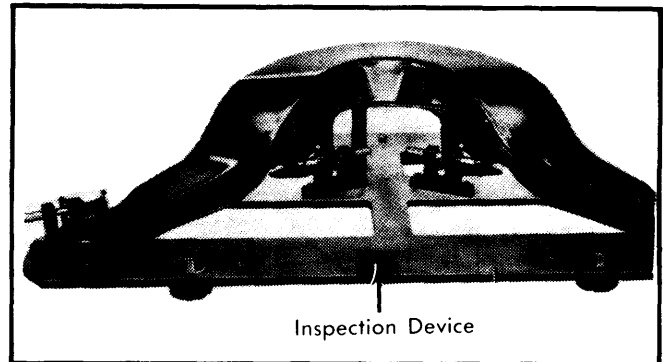

Fig. 6 Inspection Tool 115 589 04 23 00

TIGHTENING SPECIFICATIONS

Application	Ft. Lbs. (mkg)
Shock Absorber Lower Mount.....	33 (4.6)
Torsion Bar Bearing Bolts.....	47 (6.5)
Torsion Bar Connecting Rod	
Ball Joints.....	33 (4.6)
Rear Rubber Mount-to-End Cover.....	101 (14.0)
Rear Rubber Mount-to-Frame.....	18 (2.5)
Front Rubber Mounts-to-Frame.....	29 (4.0)
Supporting Plate-to-Frame.....	23-29 (3.2-4.0)
Drive Shaft Clamp Nut	
(Two Piece).....	145 (20.0)
Drive Shaft Clamp Nut (Three Piece)	
Front.....	23-29 (3.2-4.0)
Rear.....	145 (20.0)
Semi-Trailing Arm-to-Rear	
Axle Carrier.....	87 (12.0)
Axle Shaft-to-Axle Shaft Flange.....	69 (9.5)
Differential-to-Rear Axle Carrier.....	72 (10.0)
Brake Caliper Bolts.....	23-29 (3.2-4.0)