

MAZDA GLC, 626 & RX7

GLC
Except Wagon
626
RX7

DESCRIPTION

Rear suspension is a coil spring type, using trailing upper and lower control arms as pivot supports. On GLC and 626 models, the coil springs mount ahead of the rear axle directly on the lower control arms. On RX7 models, coil springs mount on rear axle housing. GLC and 626 models use a lateral rod to control side-to-side axle movement, while RX7 models use a 3-piece Watt linkage. Shock absorbers are mounted behind the rear axle housing at the lower ends and to the chassis on the upper ends.

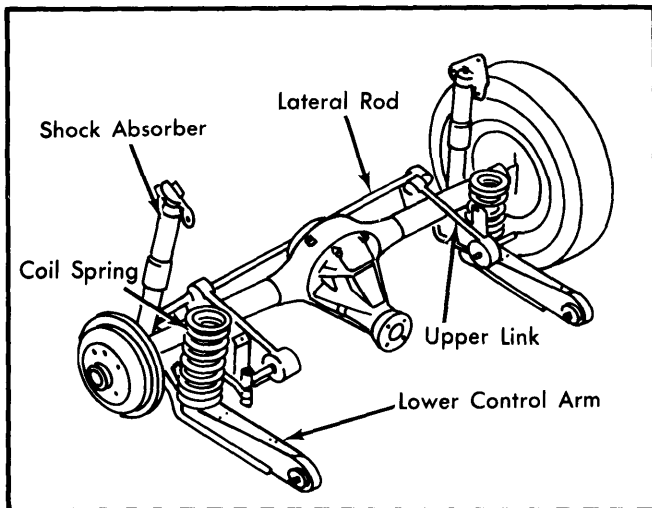

Fig. 1 GLC & 626 Rear Suspension Assembly

REMOVAL & INSTALLATION

SHOCK ABSORBERS

Removal — Raise and support rear of vehicle. Remove wheels. Disconnect upper shock absorber mounting. Remove lower shock absorber mount nuts. Remove shock absorber.

Installation — To install, reverse removal procedure and tighten nuts and bolts to specifications.

COIL SPRINGS

Removal (GLC) — Raise and support rear of vehicle. Remove rear wheels. Support rear axle housing with a jack. Remove shock absorber. Remove lower arm pivot bolt at axle housing and slowly lower axle. Remove spring.

Removal (626) — Disconnect shock absorber lower end. Disconnect lateral rod at axle housing. Disconnect upper and lower control pivot bolts at axle housing. Disconnect rear stabilizer bar (if equipped). Slowly lower axle and remove spring.

Removal (RX7) — Disconnect shock absorber lower end. Disconnect upper and lower control arm pivot bolts at axle housing. Disconnect Watt links at axle housing. Disconnect stabilizer bar (if equipped). Slowly lower axle and remove spring.

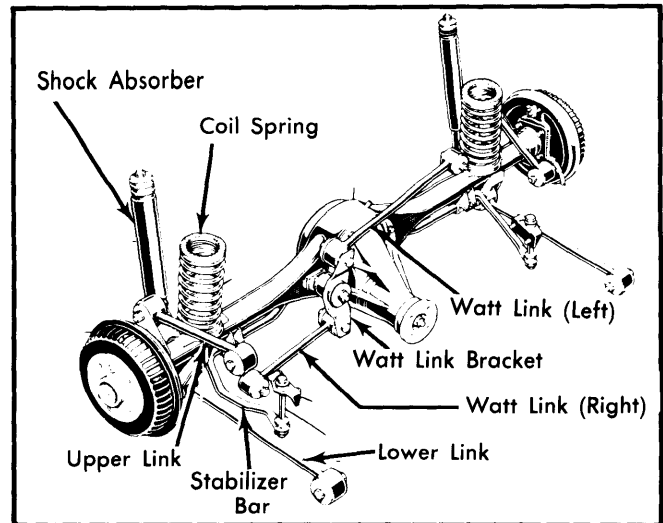

Fig. 2 RX7 Rear Suspension Assembly

Installation (All Models) — Reverse removal procedure. Tighten all nuts and bolts to specifications after vehicle has been lowered to the ground.

CONTROL ARMS, LINKS & RODS

Removal — Raise and support vehicle. Remove control arms, lateral rods or Watt links by removing attaching nuts and bolts, noting their proper installed locations.

Inspection — Inspect all components for wear or damage. Inspect and replace bushings as necessary.

Installation — To install, reverse removal procedure. Tighten all nuts and bolts to specifications after vehicle has been lowered to the ground.

STABILIZER BAR

Removal — Raise and support rear of vehicle. Remove attaching nuts and bolts. Remove stabilizer bar and hardware.

Inspection — Inspect all components for wear or damage. Replace parts as necessary.

Installation — Reverse removal procedure. Tighten nuts and bolts to specifications after vehicle has been lowered to the ground.

TIGHTENING SPECIFICATIONS

Application	Ft. Lbs. (mkg)
Upper and Lower Control Arm Bolts	
GLC	47-59 (6.5-8.2)
626 & RX7	56-76 (7.7-10.5)
Shock Absorber-to-Mount	47-59 (6.5-8.2)
Shock Absorber Bracket-to-Body	34 (4.7)
Lateral Rod-to-Mounts	
GLC	47-59 (6.5-8.2)
626	56-76 (7.7-10.5)
Watt Links-to-Mounts	47-59 (6.5-8.2)
Watt Link Bracket-to-Axle	56-76 (7.7-10.5)
Stabilizer Bar Mount-to-Body	27-38 (3.8-5.3)
Stabilizer Bar Mount-to-Axle	27-38 (3.8-5.3)