

## TOYOTA PICKUP

Pickup

### REMOVAL & INSTALLATION

#### DESCRIPTION

Independent front suspension with torsion bars. Wheel is supported by steering knuckle mounted between upper and lower control arms by ball joints. Upper and lower control arms pivot on shafts connected to frame. Torsion bars mount in anchor arms at frame and in torque arms mounted to lower control arms. Strut bars mount at frame and at lower control arm ends. Hydraulic shock absorbers mount between lower control arms and frame. A stabilizer bar is mounted to frame and connected at ends to lower control arms.

#### ADJUSTMENT

#### WHEEL ALIGNMENT SPECIFICATIONS & PROCEDURES

See *Wheel Alignment Specifications & Procedures* in *WHEEL ALIGNMENT* Section.

#### WHEEL BEARING ADJUSTMENT

See *Wheel Bearing Adjustment* in *WHEEL ALIGNMENT* Section.

#### BALL JOINT CHECKING

See *Ball Joint Checking* in *WHEEL ALIGNMENT* Section.

#### SHOCK ABSORBERS

**Removal** – Raise vehicle and place on jack stands under frame. Remove wheel and tire. Remove nuts from upper shock absorber stem. Remove bolts securing shock absorber lower mount to lower control arm.

**Installation** – To install, reverse removal procedure. Tighten all nuts and bolts.

#### TORSION BAR

**Removal** – 1) Raise and support front of vehicle. Remove wheel. Remove torsion bar boots at both ends and mark anchor arm and torque arm for correct spline alignment during reassembly.

2) Remove adjuster bolt lock nut. Measure distance from end of adjuster bolt to lower face of adjusting nut. Record distance for use during installation.

3) Place a jack under the anchor arm and raise slightly. Remove adjusting nut, lower jack slowly and remove the anchor arm and torsion bar.

**Inspection** – Inspect all parts for wear or damage. Check all splines carefully. Note that left and right torsion bars are not interchangeable.

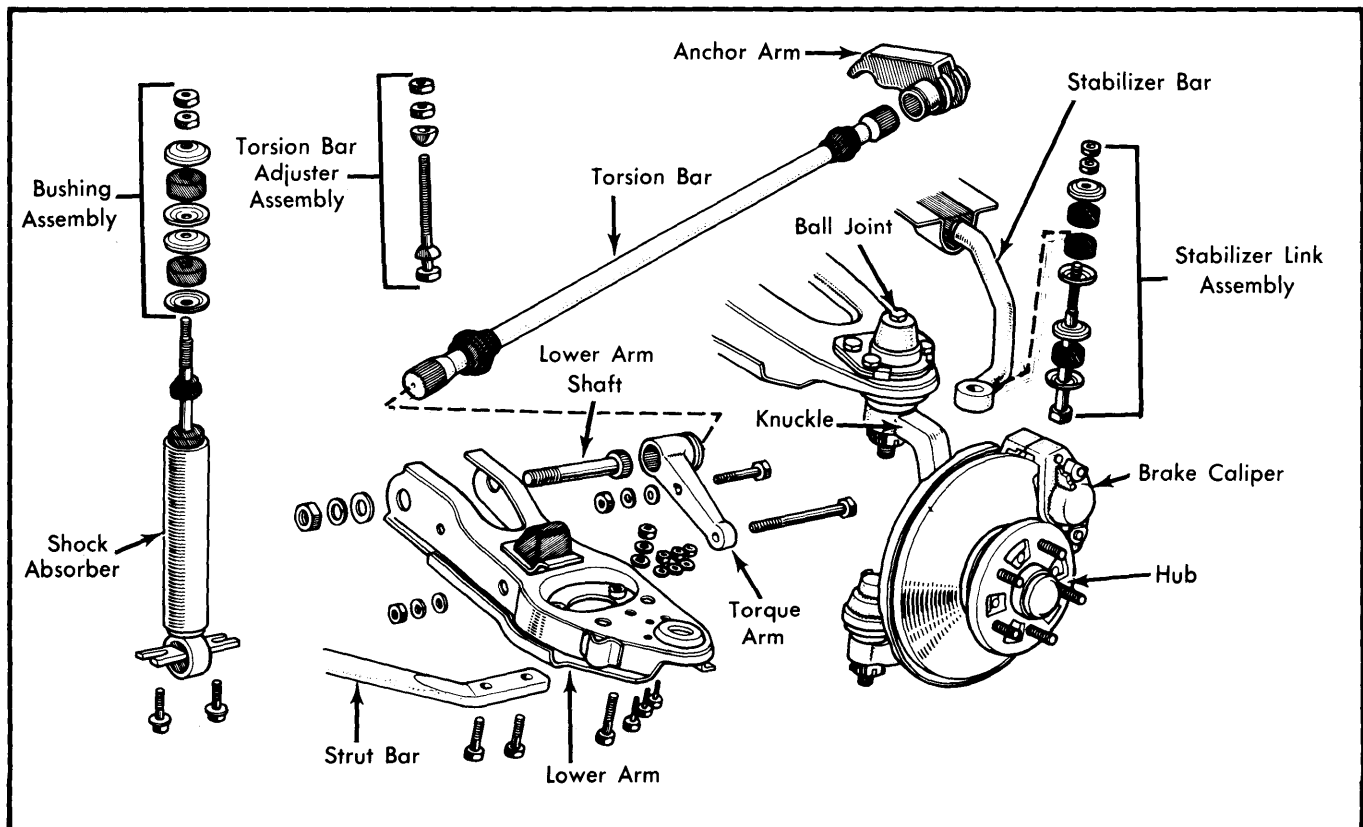

**Fig. 1 Exploded View of Toyota Pickup Front Suspension**

# Front Suspension

## TOYOTA PICKUP (Cont.)

**Installation** — 1) Grease splines prior to installation. Align marks on torsion bar with torque arm and install. Align marks on torsion bar with anchor arm and install.

2) Place a jack under anchor arm and raise until measured distance of adjusting bolt and nut is attained. Install lock nut. Install boots.

**NOTE** — If installing a new unmarked torsion bar, the correct spline position will indicate a measured distance of .7-1.00" (18-25 mm) at the adjusting bolt when bar is in unloaded position. Jack the anchor arm up until the distance is 2.4-3.0" (60-77 mm) on  $\frac{3}{4}$  ton vehicles and 2.8-3.5" (71-89 mm) on  $\frac{1}{2}$  ton vehicles.

3) Verify vehicle height and check wheel alignment.

### UPPER CONTROL ARM & BALL JOINT

**Removal** — 1) Raise vehicle by placing jack under lower control arm. Place stands under frame and leave jack in place. Remove wheel. Remove cotter pin and nut from upper ball joint stud. Using a puller, separate ball joint from knuckle.

2) Remove bolts securing upper control arm shaft, noting size and number of shims between pivot shaft and frame. Remove control arm as an assembly. Remove bolts securing ball joint to control arm, and remove ball joint. Press off bushings using suitable adapters and remove shaft.

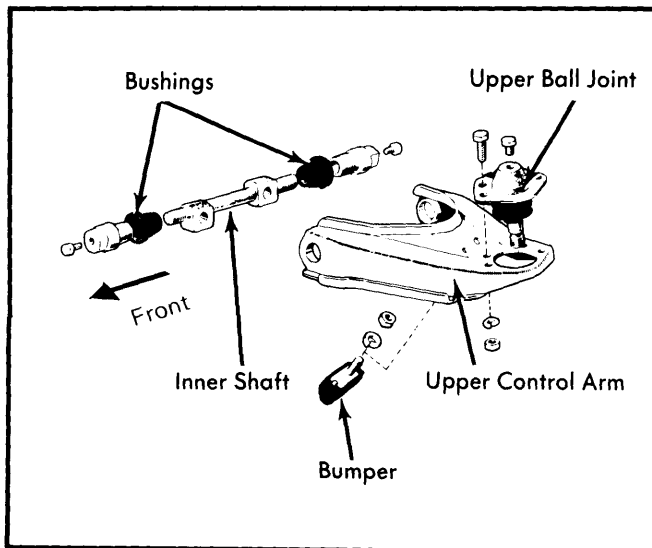

Fig. 2 Exploded View of Upper Control Arm Assembly

**Installation** — Inspect all components for wear or distortion. Install pivot shaft with offset mounting hole to front. Reverse removal procedure for installation, making sure wheel alignment shims are installed in correct position. Tighten all bolts and nuts to specifications. Check wheel alignment.

### LOWER CONTROL ARM & BALL JOINT

**Removal** — 1) Raise and support vehicle. Remove wheel. Remove torsion bar and shock absorber. Disconnect stabilizer bar and strut bar from control arm. Remove cotter pin and nut from tie rod end stud and separate from steering knuckle.

2) Remove cotter pin and nut from lower ball joint stud and, using a puller, separate ball joint from steering knuckle. Remove torque arm and pivot shaft from control arm. Remove control arm from vehicle. Remove bolts securing ball joint to control arm and remove ball joint. Remove bushings from frame, if necessary.

**Installation** — To install, reverse removal procedure, noting the following: Tighten lower arm mount nut to specifications after vehicle has been lowered to the ground. Check wheel alignment.

### STEERING KNUCKLE

**Removal** — 1) Raise and support vehicle. Remove wheel. Remove brake assembly from steering knuckle. Remove torsion bar.

2) Remove cotter pins and nuts from ball joint studs. Use a puller and separate ball joints from steering knuckle. Remove knuckle.

**Installation** — To install, reverse removal procedure. Check wheel alignment.

### TIGHTENING SPECIFICATIONS

Application	Ft. Lbs. (mkg)
Lower Ball Joint-to-Steering Knuckle .....	87-123 (12.0-17.0)
Upper Ball Joint-to-Steering Knuckle .....	66-94 (9.0-13.0)
Ball Joint-to-Lower Arm (8 mm) .....	15-21 (2.0-3.0)
Ball Joint-to-Lower Arm (10 mm) .....	29-39 (4.0-5.5)
Ball Joint-to-Upper Arm .....	15-21 (2.0-3.0)
Lower Arm-to-Frame .....	145-217 (20.0-30.0)
Upper Arm Shaft-to-Frame .....	51-65 (7.0-9.0)
Upper Arm-to-Shaft .....	62-79 (8.5-11.0)
Strut Bar-to-Lower Arm .....	55-75 (7.5-10.5)