

## LUV (Cont.)

of one shim from front bolt to rear bolt will decrease positive caster. For correct specifications, refer to table.

### CAMBER

Camber is adjusted by adding or subtracting shims. Adding an equal number of shims at both front and rear of pivot shaft will decrease positive camber. For correct specifications, refer to table.

### TOE-IN

**NOTE** — Toe-in must be adjusted after caster and camber adjustment.

Toe-in can be adjusted by rotating the intermediate rod after loosening lock nuts. Rotating intermediate rod towards front of vehicle reduces toe-in and towards rear of vehicle increases toe-in. For correct specifications, refer to specifications table.

## MAZDA

### ADJUSTMENT

#### TIRE INFLATION (COLD)

Before attempting to check or adjust wheel alignment, make sure tires are properly inflated. Refer to manufacturer's specifications given in owner's manual.

### CASTER

**GLC** — Caster is not adjustable. If caster is not to specifications, inspect suspension for excessive wear or damage. Replace components as necessary.

**RX7 & 626** — Caster and camber angles are adjusted by changing position of shock absorber support. To adjust, remove four nuts attaching shock absorber support to fender apron. Raise front of vehicle and support with jack stands, then remove wheel on side to be adjusted.

2) Press shock absorber downward and change position of support according to table and Fig. 1. Tighten shock absorber support mounting nuts. Install wheel, lower vehicle and recheck caster and camber.

Caster and Camber Adjustment			
Adjustment		Variation	
	Shock Absorber Support	Caster	Camber
A	0	0	0
B	90°	½ °	0
C	180°	½ °	½ °
D	270°	0	½ °

**Pickup** — To adjust, change shims between upper arm shaft and support bracket or turn upper arm shaft until specifications are obtained.

### CAMBER

**GLC** — Camber is not adjustable. If caster is not to specifications, inspect suspension for excessive wear or damage. Replace components as necessary.

**RX7 & 626** — See procedure given under Caster adjustment.

**Pickup** — To adjust, change shims between upper arm shaft and support bracket until specifications for camber are within limits.

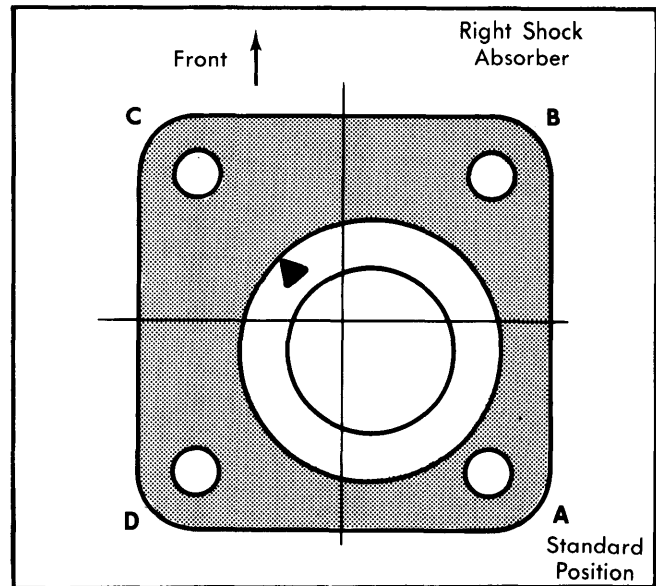

Fig. 1 RX7 & 626 Caster and Camber Adjusting Pad (Position "C" Shown)

### TOE-IN

**All Models** — 1) Raise front of vehicle. Turn wheels by hand and mark a line in center of each tire tread. Place vehicle in straight-ahead position and lower vehicle to ground.

2) Measure distance between marked lines at both front and rear of wheel. Make sure measurements are made equal distances from ground. Distance at rear of wheel should be .24" (6 mm) more than that at front wheels. Loosen lock nuts and turn tie rods until adjustment is correct.

## MERCEDES-BENZ

### ADJUSTMENT

### CASTER

#### TIRE INFLATION (COLD)

Before attempting to check or adjust wheel alignment, make sure tires are properly inflated. Refer to manufacturers specifications given in owner's manual.

**All Models (Front)** — Test under loaded condition. Load vehicle with two 143 lb. weights on rear seat and full tank of gasoline. If caster is not to specifications, loosen lock nut on eccentric bolt on front side of lower control arm. To adjust, rotate