

# Wheel Alignment

## FIESTA

### ADJUSTMENT

#### TIRE INFLATION (COLD)

Before attempting to check and adjust wheel alignment, make sure tires are properly inflated. Refer to manufacturer's specifications given in owner's manual.

#### CASTER

Caster is not adjustable. If caster is not to specifications, inspect suspension system for wear or damage and repair or replace components as necessary.

#### CAMBER

Camber is not adjustable. If camber is not to specifications, inspect suspension system for wear or damage and repair or replace components as necessary.

#### TOE-IN

Loosen lock nuts on outer ends of tie rods. Lock nuts are located next to ball joints. Loosen clamps on outer ends of steering gear bellows. Adjust both tie rods equal amounts until toe-in is within specifications. Tighten lock nuts. Install new clips to outer ends of bellows.

## HONDA

### ADJUSTMENT

#### TIRE INFLATION (COLD)

Before checking or adjusting wheel alignment, make sure tires are correctly inflated. Refer to manufacturers specifications located in glove box.

#### RIDING HEIGHT

Make sure tires are properly inflated. Measure from bottom of side marker lamps (top of front wheel opening on Prelude) to ground. If height measurement is not within specifications, check rear height before attempting to repair front suspension.

#### Riding Height Specifications

Application	Front	Rear
Civic .....	25.98" ..... (660 mm)	23.03" ..... (585 mm)
Civic CVCC Sedan .....	24.2" ..... (615 mm)	20.7" ..... (525 mm)
Station Wgn. ....	24.2" ..... (615 mm)	22.9" ..... (583 mm)
Accord .....	24.0" ..... (610 mm)	25.4" ..... 645 mm)
Prelude .....	24.4" ..... (620 mm)	24.2" ..... (615 mm)

**NOTE** — Civic specifications are new limits, all others are service limits.

#### CASTER

Caster is nonadjustable. If alignment is not within specifications, inspect for damaged parts and replace as necessary.

#### CAMBER

Camber is nonadjustable. If alignment is not within specifications, inspect for damaged parts and replace as necessary.

#### TOE-OUT

**Civic CVCC, Accord & Prelude (Front)** — Loosen lock nuts at each end of tie rods. Turn tie rod until toe-out is within specifications. Use same procedure for both sides. To center steering wheel after toe has been adjusted, turn both tie rods in same direction until steering wheel (spokes) are centered. Tighten lock nuts.

#### TOE-IN

**Civic CVCC, Accord & Prelude (Rear)** — To adjust toe-in, loosen nuts on radius rods. Rotate radius rods until toe-in is within specifications, then tighten lock nuts. On Accord models, each notch on cam plate is equal to .197" (5 mm). On Prelude models, each notch on cam plate is equal to .630" (16 mm).

## JAGUAR

### ADJUSTMENT

#### TIRE INFLATION (COLD)

Before attempting to check or adjust wheel alignment, make sure tires are properly inflated. Refer to owner's manual for manufacturer's specifications.

#### RIDING HEIGHT

**All Models (Front)** — 1) Check that vehicle is full of fuel, oil, and water, and that tires are properly inflated. Press down on

front bumper and slowly release, then lift up on bumper and slowly release, this will settle front suspension.

2) On XJ6 and XJ12 models, measure distance between center of outer headlight and ground on both sides of vehicle. Height should be 24.6" (611 mm) minimum.

3) On XJS models, measure distance between lower face of crossmember and ground on both sides. Height should be 6.0" (152 mm) minimum, plus thickness of slip plates.

## JAGUAR (Cont.)

4) On all models, adjust by installing or removing spring spacers from front coil springs. **NOTE** — Spring spacers are  $\frac{1}{8}$ " (3.2 mm) thick and will change riding height approximately  $\frac{3}{16}$ " (7.9 mm).

**All Models (Rear)** — Check that vehicle is full of gasoline, water and oil, and that tires are properly inflated. Roll vehicle forward three car lengths to settle suspension system. Measure distance between lower surface of rear crossmember and ground on both sides of vehicle. Correct height should be  $7.45 \pm .25$  (189  $\pm$  6 mm). If height is correct, it will be unnecessary to proceed further, however if height is incorrect, all four rear springs will need to be replaced.

### PREPARATION FOR CASTER & CAMBER ADJUSTMENT

1) Ensure vehicle is on level ground and that tires are properly inflated. Before checking or adjusting caster or camber it will be necessary to fabricate two setting tools (See Fig. 1).

2) Compress front suspension and insert tools under upper control arms, adjacent to control arm rubber stops and over brackets welded to bottom of control arms.

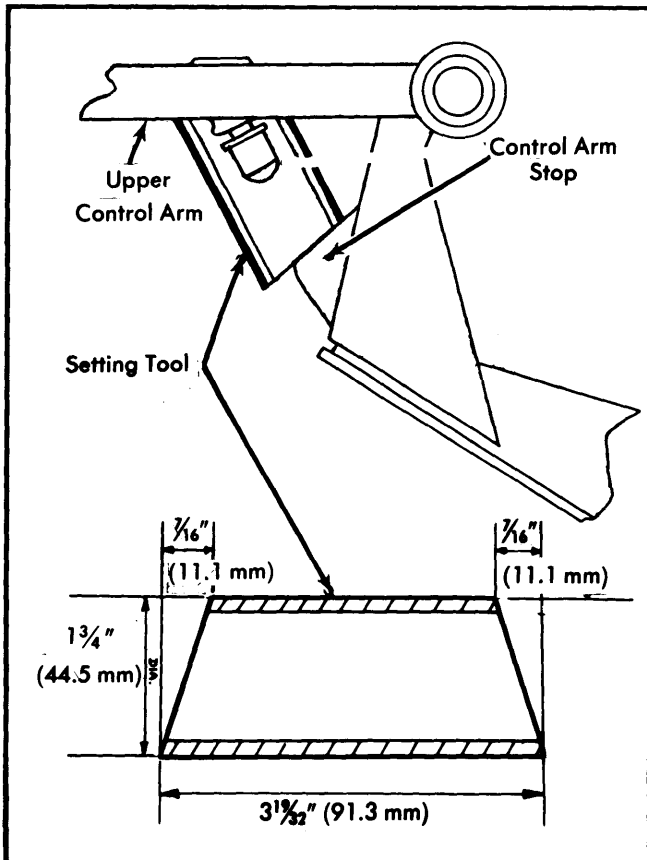

Fig. 1 Dimensions for Fabricating the Two Necessary Setting Tools

3) Compress rear suspension and install suitable suspension setting links (J. 25), to lock rear suspension in place (See Fig. 2). Vehicle is now locked in half-loaded condition and caster and camber can be checked and adjusted.

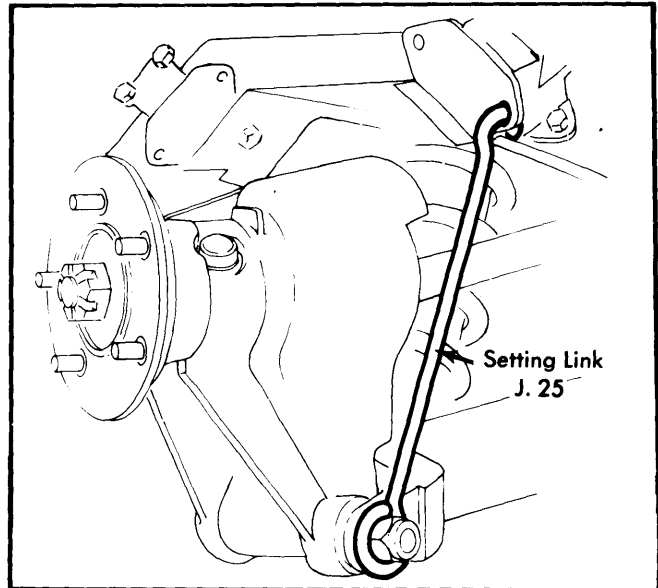

Fig. 2 Rear Suspension in Locked Position with Special Tool

### CASTER

**NOTE** — Before adjusting caster angle, make sure car is standing at normal riding height.

**All Models** — If caster angle is not within specifications, adjust by moving shims on front and rear of upper control arm ball joint. To increase caster, loosen bolts securing upper ball joint and move shims from rear of ball joint to front of ball joint. To decrease caster, reverse procedure. Tighten ball joint attaching bolts and recheck caster angle.

### CAMBER

**NOTE** — Before attempting to check or adjust camber angle it will be necessary to make sure that vehicle is in half-loaded condition.

**All Models (Front)** — Place wheels in straight-ahead position. Measure camber angle. Make sure front wheels are within  $\frac{1}{4}$ ° of each other. Adjustment is accomplished by adding or subtracting shims. See Fig. 3. Adding shims increases camber angle. Make sure same number of shims are used on each bolt.

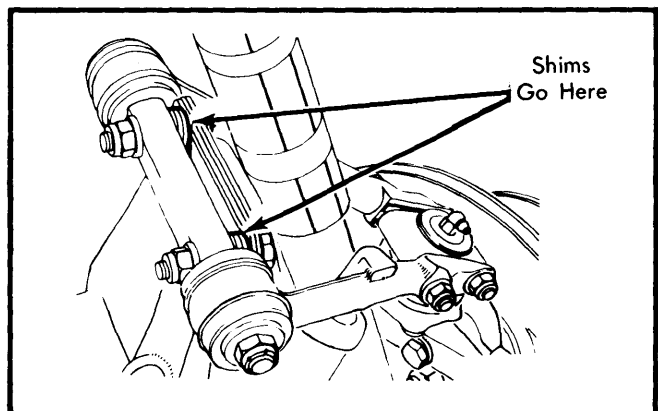
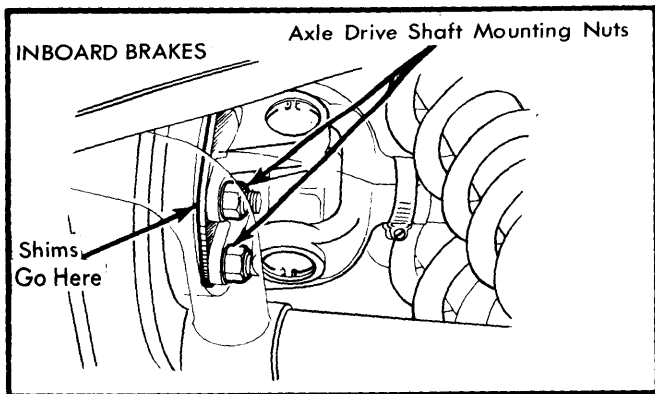

Fig. 3 Shim Placement for Front Camber Angle Adjustment

# Wheel Alignment

## JAGUAR (Cont.)



**Fig. 4 Placement of Shims for Rear Camber Angle Adjustment**

**All Models (Rear)** — Before checking rear wheel camber, rear suspension must be in the half-loaded position. See

**Preparation for Caster & Camber Adjustment.** To adjust, remove suspension setting links (JD.25), raise and support rear of vehicle and remove wheels. Loosen nuts securing half-shaft to brake disc, then add or remove shims as required to bring camber angle within specifications.

**NOTE** — Addition of one .020" (.5 mm) shim will alter camber 1/4°.

### TOE-IN

**All Models** — Place vehicle in straight-ahead position. Remove grease nipple from rack adjuster nut. Put centralizing tool 12279 (or equivalent) into locating hole. Push tool on to back of rack bar. Slowly turn steering wheel until tool drops into back of rack bar. Measure toe-in. If toe-in is not within specifications, adjust by loosening steering link lock nuts and rotating adjuster sleeves equal amounts, as necessary. Tighten lock nuts and recheck toe-in.

## LUV

### ADJUSTMENT

#### TIRE INFLATION

Before checking or adjusting wheel alignment, ensure tires are correctly inflated. Refer to manufacturers specifications located in glove box or on right hand door jam.

#### RIDING HEIGHT CHECKING

1) Place vehicle on smooth level surface. Bounce vehicle several times. Raise vehicle and allow to settle at normal height. Measure distance as shown in Fig. 1 and 2.

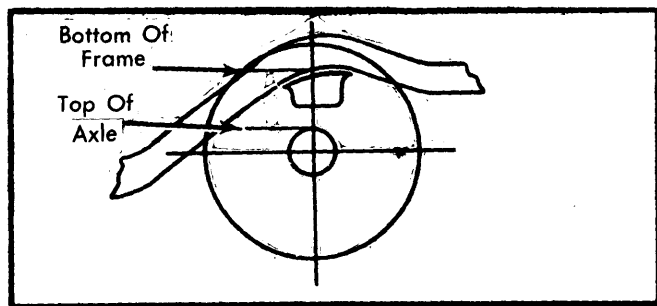

**Fig. 1 Rear Suspension Riding Height Measuring Point**

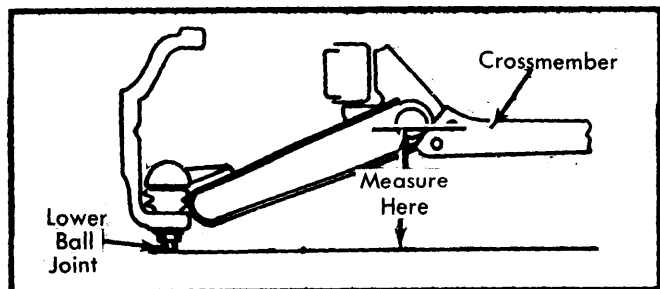

**Fig. 2 Front Suspension Riding Height Measuring Point**

**NOTE** — Height check should be made with a full tank of gas, spare tire installed, and jack included. No passengers should be in vehicle.

2) Difference between measurements of each side must not be more than 1/2". If an adjustment is necessary, it can be made at bolt on height control arm.

#### Riding Height Specifications

Application	Front	Rear
LUV 2 Wheel Drive		
Standard	4.6" (116.8 mm)	6.1" (155 mm)
Long Wheelbase	4.6" (116.8 mm)	7.5" (190 mm)
LUV 4 x 4	4.8" (122 mm)	7.7" (195 mm)

#### TORSION BAR SPRING HEIGHT

1) Park vehicle on level surface. Jounce vehicle several times and allow vehicle to return to settled position.

2) On 2 wheel drive vehicles, measure buffer clearance between rubber bumper and lower control arm. Using bolt located on height control arm, adjust buffer clearance to about .866" (22 mm).

3) On all models, turn adjuster bolt on torsion bar until riding height measurement is to specifications.

**NOTE** — Rotating bolt inward increases vehicle height.

### CASTER

Adjustment is made with shims inserted between upper control arm pivot shaft and frame. Adding or subtracting shims from either front or rear bolts will effect a change in caster. Shims may be transferred from front to rear or rear to front. Transfer