

## RENAULT

### Le Car

### DESCRIPTION

Brake system is hydraulically operated by a tandem master cylinder. Some vehicles may be equipped with a power brake unit. All models are fitted with front disc brakes and rear drum brakes. A pressure limiter valve is used to regulate pressure to rear wheels and prevent rear wheel lock-up. Parking brake cable is lever operated from between the front seats.

### ADJUSTMENT

#### DISC BRAKES

Disc brakes are self adjusting; therefore, no adjustment in service is required.

#### DRUM BRAKES

Two adjusting lugs are located on backing plate. Using a wrench, turn front lug counterclockwise and rear lug clockwise until shoes just contact drum. Then, back off adjustment until drum rotates freely.

#### PARKING BRAKE

Adjust brake shoes. Then, fully release parking brake lever. Loosen lock nut on adjustment rod. Tighten adjustment nut until lining just meets drum. At this point parking brake lever travel should be about 6 notches. Tighten lock nut. Check operation.

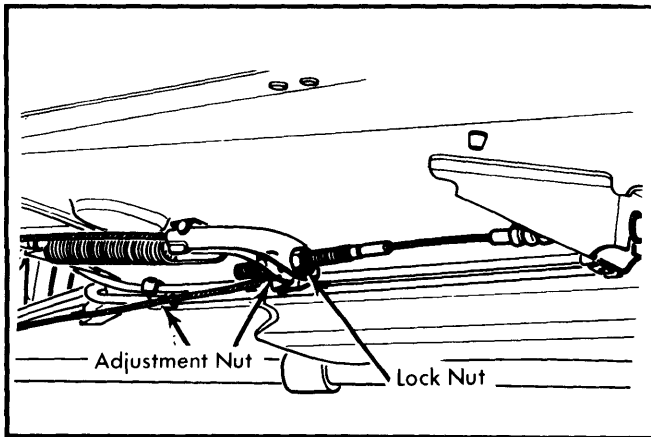

Fig. 1 Parking Brake Adjustment Points

#### REAR BRAKE PRESSURE LIMITER

**NOTE** - Limiter must always be checked and adjusted with vehicle on level ground, trunk empty and drivers seat occupied.

1) To check limiter, remove 1 rear wheel cylinder bleeder screw and connect a pressure gauge (Fre. 214-02) into vacant hole. Bleed brake system. Depress brake pedal and check pressure obtained at wheel cylinder. Pressure should be as shown in table.

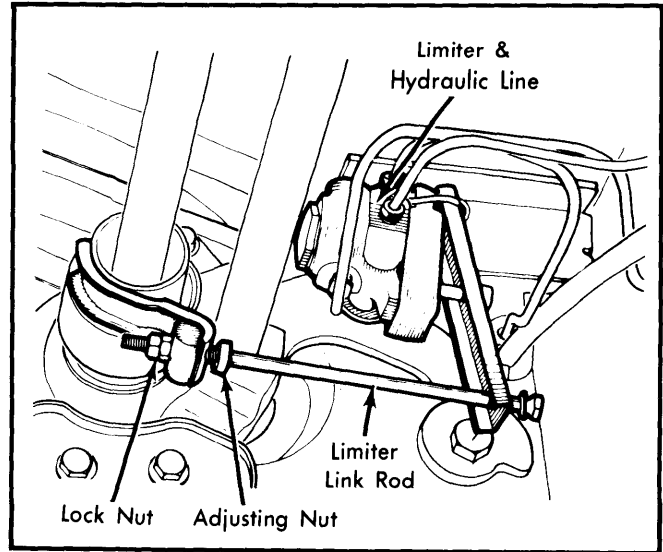

Fig. 2 Pressure Limiter Adjustment Points

- 2) To adjust limiter, release lock nut and tighten adjustment nut to **increase** pressure or loosen it to **reduce** pressure.
- 3) Apply brake pedal several times and recheck adjustment. Remove pressure gauge and bleed brake system.

#### Pressure Limiter Adjustment

Application	⊙psi (kg/cm <sup>2</sup> )
Le Car .....	435±30 (30.5±2)

⊙ - With fuel tank full.

#### HYDRAULIC SYSTEM BLEEDING

**NOTE** - On vehicles equipped with power assisted brakes, release vacuum from servo unit prior to bleeding brakes.

Fill brake reservoir, and connect pressure bleeder. **NOTE** - Do not exceed 30 psi with pressure bleeder. Check each bleeder screw for fluid flow. Close bleeder screw when fluid flowing from screw is free of air. Remove pressure bleeder, and check fluid level in reservoir.

#### REMOVAL & INSTALLATION

##### DISC BRAKE PADS

**Removal & Installation** - Caliper must be removed to replace disc pads. See *Disc Brake Caliper Removal & Installation*.

##### DISC BRAKE CALIPER

**Removal** - Raise and support vehicle and remove front wheels. Remove spring clips and slide keys out of caliper and mounting bracket. Disconnect brake line fitting from flexible hose and remove hose retaining clip from body. Remove caliper from mounting bracket and disconnect flexible hose from caliper. Remove brake pads and pad spring from caliper.

## RENAULT (Cont.)

**Installation** — To install, reverse removal procedure and note the following: Install longest pad spring on outside of caliper. Tighten all fittings and bleed hydraulic system.

### DISC BRAKE ROTOR

**Removal & Installation** — Remove caliper and caliper mounting bracket. Remove stub axle nut. Fit slide hammer and remove hub/rotor assembly. Separate rotor from hub. To install, reverse removal procedure.

### BRAKE DRUM

**Removal** — Remove hub grease cap, cotter pin, nut and washer. Back off brake shoe adjusters. Attach slide hammer and remove drum.

**Installation** — To install reverse removal procedure and note the following: Apply a suitable grease to wheel bearings. After installing drum assembly, adjust wheel bearings. See *Wheel Bearing Adjustment* in *WHEEL ALIGNMENT* Section. Apply brake pedal several times to adjust brake shoes.

### DRUM BRAKE SHOES

**Removal & Installation** — Remove wheel and brake drum from vehicle. Install wheel cylinder clamp, then remove upper brake shoe return spring. Disconnect parking brake cable from actuator lever. Remove parking brake actuator link and lower return spring. Unhook shoe hold-down springs and remove brake shoes. To install, reverse removal procedure.

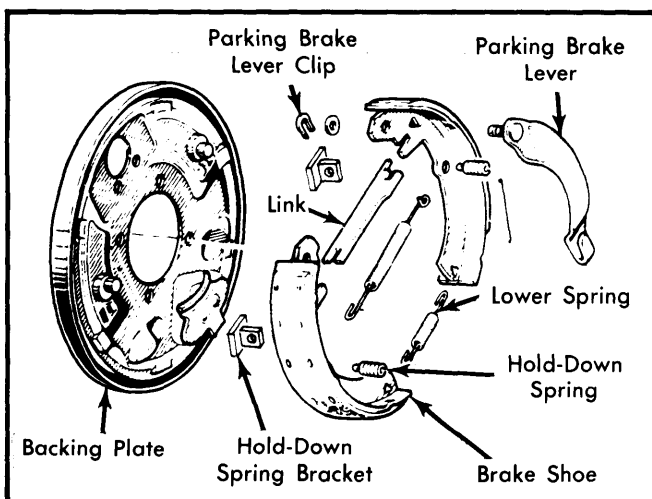

Fig. 3 Exploded View of Brake Shoe Assembly

### WHEEL CYLINDER

**Removal & Installation** — Remove brake drum and brake shoes from vehicle. Disconnect brake line from wheel cylinder, and remove cylinder attaching bolts. Remove cylinder from vehicle. To install, reverse removal procedure and bleed hydraulic system.

### MASTER CYLINDER

**Removal & Installation** — Siphon fluid from master cylinder reservoir. Disconnect hydraulic lines at master cylinder and plug open ends. Remove pressure loss indicator bolt (if equipped.) Disconnect push rod from brake pedal if vehicle is not equipped with power unit. Remove cylinder mounting

hardware and remove cylinder from vehicle. To install, reverse removal procedure and adjust push rod clearance. Clearance, measured between piston and push rod, should be .20" (5 mm).

### POWER BRAKE UNIT

**NOTE** — Power brake unit is not serviceable, only the air filter and check valve can be serviced.

**Removal** — Disconnect battery, and remove fluid from master cylinder. Remove engine air filter (if necessary). Disconnect hydraulic lines at master cylinder, and remove pressure loss indicator valve bolt (if equipped). Disconnect vacuum hose, and remove clevis from brake pedal. Remove power brake unit attaching nuts from pedal side of firewall, and remove master cylinder and power brake unit as an assembly. Separate master cylinder from power brake unit.

**Installation** — Measure push rod-to-master cylinder clearance at master cylinder mounting flange, and adjust by turning push rod nut. To install power brake unit, reverse removal procedure, and bleed hydraulic system.

## OVERHAUL

**NOTE** — Master Cylinder, Power Brake Unit, and Brake Pressure Limiter cannot be Overhauled.

### DISC BRAKE CALIPER

**Disassembly** — Remove caliper assembly from vehicle, and remove piston dust cover. Using compressed air, introduced at caliper fluid port, carefully remove piston from caliper assembly. Remove piston seal from cylinder. Using a wedge, spread legs of caliper piston bracket a small amount. Remove caliper stop peg from piston bracket. Slide cylinder assembly from bracket.

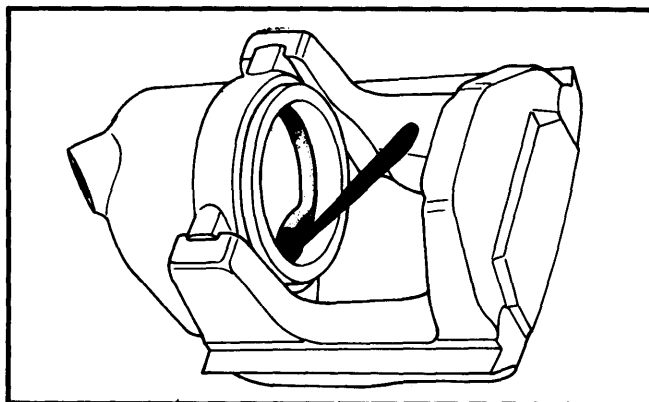

Fig. 4 Prying Out Seal from Caliper Cylinder Bore

**Inspection** — Clean all parts in denatured alcohol, and inspect for piston and cylinder wear. Replace worn parts as necessary. Replace all rubber seals.

**Reassembly** — Lubricate cylinder bore, piston, and seals with brake fluid prior to reassembly. To reassemble, reverse disassembly procedure.

# Brakes

## RENAULT (Cont.)

### WHEEL CYLINDER

**Disassembly & Reassembly** – Remove dust boots, pistons, cups and spring. Examine components for damage or excessive wear. Before disassembly, dip pistons and cups in brake fluid.

TIGHTENING SPECIFICATIONS	
Application	Fr. Lbs. (mkg)
Caliper Bracket Bolts .....	50 (6.9)
Rotor-to-Hub .....	20 (2.8)
Stub Axle Nut .....	90 (12.5)

DISC BRAKE ROTOR SPECIFICATIONS						
Application	Disc Diameter In. (mm)	Lateral Runout In. (mm)	Parallelism In. (mm)	Original Thickness In. (mm)	Minimum Refinish Thickness In. (mm)	Discard Thickness In. (mm)
Le Car	9.000 (228.5)	.004 (.1)	.....	.395 (10)	.....	.355 <sup>Ⓢ</sup> (9)

Ⓢ – Rotor cannot be machined; it must be replaced.

BRAKE DRUM SPECIFICATIONS				
Application	Drum Diameter In. (mm)	Original Diameter In. (mm)	Maximum Refinish Diameter In. (mm)	Discard Diameter In. (mm)
Le Car	7.087 (180)	7.087 (180)	7.136 (181)	.....

BRAKE SYSTEM SPECIFICATIONS				
Application	Drum Diam. In. (mm)	Wheel Cylinder Diameter		Master Cylinder Diameter In. (mm)
		Front In. (mm)	Rear In. (mm)	
Le Car	9.000 (228.5)	1.772 <sup>Ⓢ</sup> (45)	.866 (22)	.811 (20.6)

Ⓢ – Caliper Cylinder.