

## PORSCHE

911SC  
924  
928  
Turbo

### DESCRIPTION

Brake systems are hydraulically operated, utilizing a tandem master cylinder and a power brake unit. The 911SC, 928 and Turbo models are equipped with front and rear disc brakes. 924 models are equipped with front disc brakes and rear drum brakes. All models utilize mechanical parking brakes that operate off the rear brakes. All models have a brake warning light that is activated when there is a pressure drop in the hydraulic system. Warning light on instrument panel comes on and will not go off until the problem is corrected.

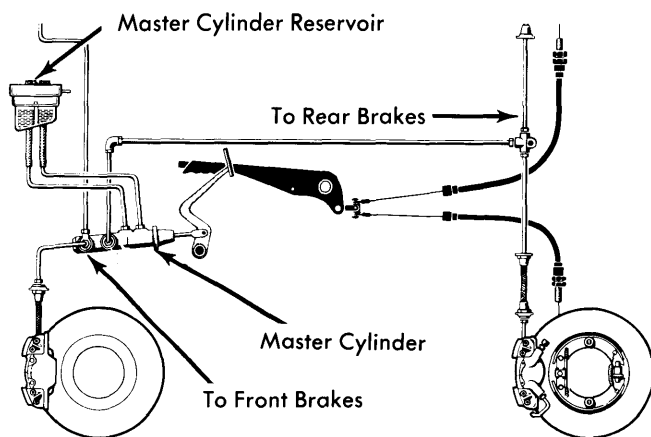

Fig. 1 Hydraulic Fluid Distribution for Dual Circuit Brake System

### ADJUSTMENT

#### DISC BRAKES

Disc brakes are self adjusting, therefore no adjustment in service is required.

#### REAR BRAKE SHOES

**924 (Rear Brakes)** — Turn adjuster until a slight drag is felt when rotating brake drum. Back off adjuster until drum is just free to rotate.

#### PARKING BRAKE

**911SC & Turbo Models** — Raise and support vehicle, and remove rear wheels. Release parking brake lever and push pistons and pads into caliper to allow rotor to turn freely. Loosen parking brake cable lock nuts until cable is slack. Working through access hole in parking brake drum, turn star wheel adjuster until rotor can no longer be turned by hand. Adjust parking brake cable at rear cable end until it just begins to pull and tighten lock nuts. Back off on star wheel adjuster until rotor turns freely without drag. Repeat procedure on opposite wheel and check parking brake operation.

**924 Models** — Raise and support vehicle and ensure rear brakes are properly adjusted. From inside of vehicle, pull parking lever up by two notches. At base of lever adjust nut until both wheels can just be turned by hand.

**928 Models** — Parking brake adjustment is the same as on the 911.

### BLEEDING SYSTEM

**Bleeding Sequence** — If equipped with outer and inner caliper half bleed screws, always bleed outer caliper half first and inner half second. Bleed brakes as follows: Left rear first, right rear second, right front third, and left front last.

**CAUTION** — When any fluid fitting is disconnected, fluid will drain from reservoir through master cylinder and out open fitting. To avoid this, depress brake pedal far enough so piston cup will pass the compensating (resupply) port.

**Pressure Bleeding** — Fill pressure bleeder with brake fluid and pressurize tank to 32.3 psi (2.2 atm). Connect bleeder to reservoir and connect a small bleed hose to first bleed screw. See Bleeding Sequence. Place other end in container partially filled with brake fluid. Open bleed screw 1/2 – 3/4 turn and allow fluid to drain until no air bubbles are apparent in fluid. Close bleed screw and repeat operation for each bleed screw in turn.

**NOTE** — If brake system was completely drained, it may be necessary to perform bleeding, in sequence, more than once.

**Manual Bleeding** — Fill reservoir with brake fluid and connect a small hose to first bleed screw. See Bleeding Sequence. Place other end in container partially filled with brake fluid. Have an assistant rapidly pump brake pedal until slight pressure is felt, then hold pedal depressed. Open bleed screw and allow fluid to drain. Close bleed screw before slowly releasing pedal. Repeat pedal action until fluid flows into container with no bubbles. Repeat at each bleed screw in turn.

### REMOVAL & INSTALLATION

**NOTE** — Rear brake calipers are now mounted on the trailing arms at the rear rather than at the front. Trailing arms have been modified with mounting holes at the rear to accommodate this change. Rear brake lines are now secured to the trailing arms with a retaining clip to prevent vibration.

#### DISC PADS

**NOTE** — Mark pads and calipers before removal. If pads are to be reused, they must be installed in original location. If only one pad on front or rear needs replacing, all four pads must be replaced.

**Removal** — Raise and support vehicle and remove wheels. On 911SC and Turbo models, squeeze spreader spring together until it is disengaged. Pull pads out with suitable wire hook. On 924 models, remove inside brake pad first. Outside brake pad is guided by a tab on caliper frame. Press out this frame to pull out brake pad. On 928 models, remove brake pad sensor from backing plate. Remove spring lock and retaining pins. Remove inner brake pad with hook. Remove outer brake pad.

**NOTE** — Depress spreader spring if required. Using a suitable extractor (P86) pull pads from caliper.

**CAUTION** — If fluid level is too high in reservoir, overflow will result when pistons (during installation) are pushed back into calipers.

## PORSCHÉ (Cont.)

**Installation** — Push piston back into caliper using suitable tool (P83), or wooden block. Remove anti-rotation locks (if equipped) and clean all parts with alcohol. Inspect all parts for damage or wear. Ensure piston 20° position is correct using suitable gauge (P84). Install remaining parts in reverse order of removal, replace parts as necessary.

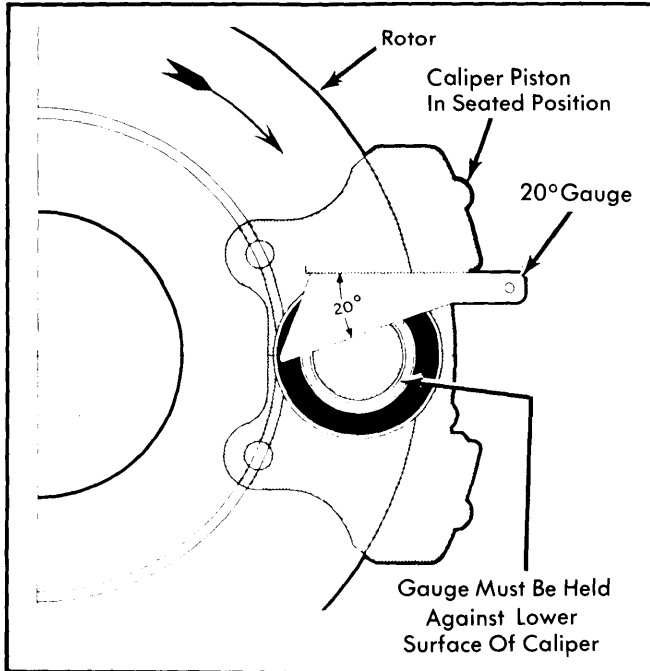

**Fig. 2** Using a 20° Gauge to Properly Position Caliper Piston

## BRAKE CALIPER

**CAUTION** — When any fluid fitting is disconnected, fluid will drain from reservoir through master cylinder and out open fitting. To avoid this, depress brake pedal far enough so piston cup will pass the compensating (resupply) port.

**Removal (Front & Rear)** — Raise and support vehicle, and remove wheels. Remove brake pads as previously outlined. Remove splash shield (if necessary), disconnect hydraulic line. Remove mounting bolts and remove caliper assembly.

**Installation (Front & Rear)** — To install, reverse removal procedure and note the following: Clean and inspect all parts for wear or damage and replace as necessary. Tighten all bolts and fittings to specifications and bleed complete brake system.

## BRAKE ROTOR

**Removal (Front)** — Remove caliper assembly as previously outlined. Remove dust cap from wheel hub, loosen clamp lock screw, then remove clamp nut and thrust washer. Remove rotor and wheel bearings as a unit. On 911SC and Turbo models, mark rotor and hub for reassembly reference, remove attaching bolts and separate rotor from hub.

**Removal (Rear)** — Remove caliper assembly as previously outlined. Remove the two rotor attaching bolts and pull rotor from hub.

**NOTE** — If rotor cannot be removed by hand, insert two 8mm bolts into attaching screw holes and alternately tighten bolts to press rotor from hub.

**Installation (Front & Rear)** — To install, reverse removal procedure, bleed brakes and adjust front wheel bearing free play. See *Wheel Bearing Adjustment* in *WHEEL ALIGNMENT* Section.

**NOTE** — Rotors must be installed in original position due to cooling holes and internal ventilation channels. These holes and channels are different for right and left sides.

## REAR BRAKE SHOES

**Removal** — Raise and support vehicle and remove wheels. Using suitable puller (40-107) remove brake drum. Remove shoe

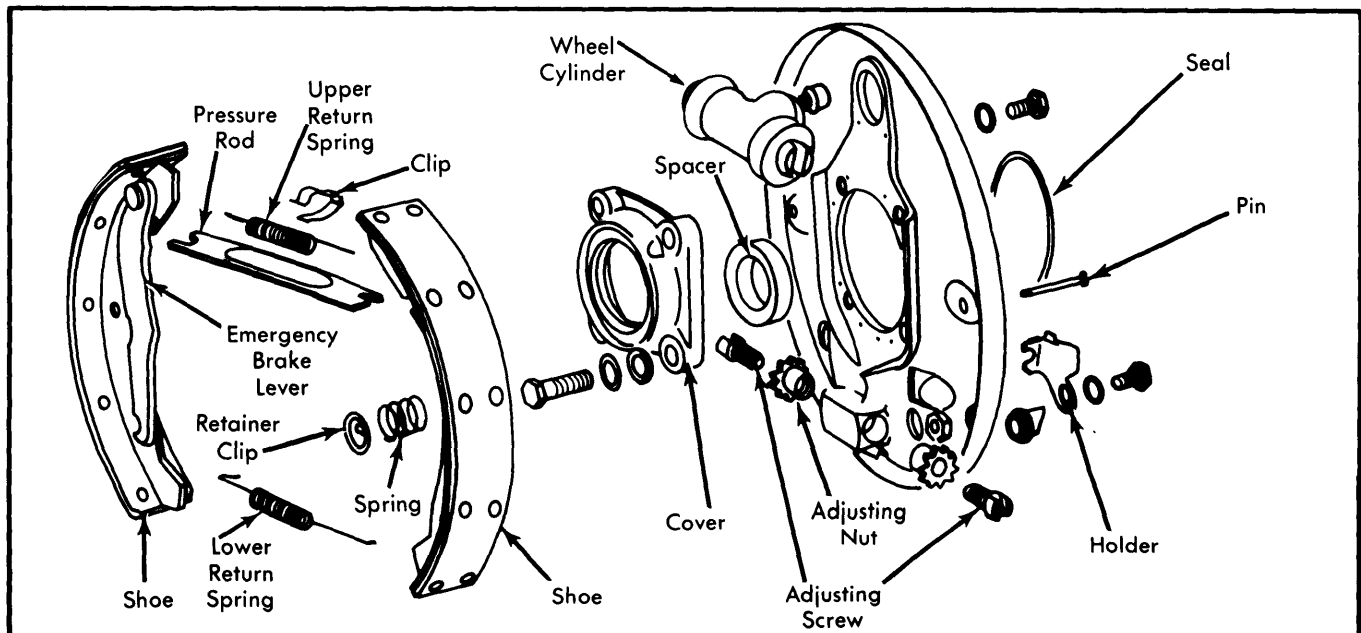

**Fig. 3** Exploded View of 924 Rear Wheel Brakes

## PORSCHE (Cont.)

hold down springs. Remove upper and lower return springs and pressure rod. Remove emergency brake rod from brake shoe.

**Installation** — Reverse removal procedures and note the following: Lubricate adjusting screws and sliding surfaces of brake shoes slightly. Use new bearing pin and clip when installing emergency brake rod.

### REAR WHEEL CYLINDER

**Removal** — With rear drum and brake shoes removed, disconnect brake line from wheel cylinder at rear of backing plate, remove bolts attaching cylinder and remove cylinder.

**Installation** — Reverse removal procedure, tighten mounting bolts and bleed hydraulic system.

### PARKING BRAKE ASSEMBLY

**Removal** — 1) On 911SC and Turbo models, remove cotter pin, castle nut and washer from cable, then remove cable from brake assembly. Remove expander and springs and shoe retaining pins, then springs from upper shoes. Raise upper shoe, withdraw adjuster and spring. Remove shoe retainer from lower shoe and remove both shoes from vehicle.

2) On 924 models, loosen mounting screws and remove entire parking brake lever. It may be necessary to remove tension spring and adjusting rod to remove assembly. On 928 models, remove caliper, loosen adjuster and remove screws and brake disc. Remove spreader, shoes, springs and adjuster.

**Installation** — To install, reverse removal procedures.

### BRAKE PRESSURE REGULATOR

**Removal** — Disconnect brake lines at pressure regulator. Remove bolts from regulator flange and take out unit.

**Checking** — Step down hard on the brake pedal while feeling the regulator body; note if piston in regulator is moving. When the brake pedal is released, a slight "knock" should be felt on regulator body.

**Installation** — To install, reverse removal procedure and bleed brake system.

**NOTE** — Brake pressure units can not be overhauled.

### MASTER CYLINDER

**Removal** — On 911SC and Turbo models, raise and support vehicle and drain fluid from reservoir. Pull back on accelerator pedal to detach pedal from rod. Remove floor mat and floor board and withdraw boot from master cylinder. Remove underpanel covering front axle, remove brake lines, electrical leads and reservoir tubes from cylinder and remove master cylinder from vehicle. On 924 and 928 models, remove hydraulic lines from master cylinder and remove electrical connections. Remove mounting nuts and remove master cylinder.

**Installation** — Reverse removal procedures and note the following: On 911SC and Turbo models, be sure push rod is

correctly installed and that clearance between push rod and piston is about .04" (1.0 mm). Use a sealing material on cylinder flange to prevent water leakage into driver's compartment. Bleed both systems as previously outlined.

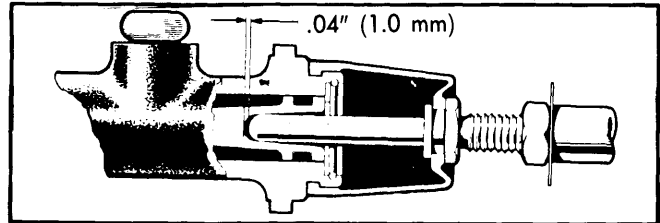

Fig. 4 Illustrating Push Rod-to-Master Cylinder Piston Clearance on 911SC & Turbo Models

### POWER BRAKE UNIT

**NOTE** — Before removal or overhaul test check valve and power brake unit for operation. To check valve, pull off vacuum hose, place finger over check valve and crank engine, vacuum should be created. To check power brake unit, push on brake pedal several times with engine stopped, hold pedal down and start engine. If power brake unit is operating properly brake pedal will drop slightly.

**Removal** — With master cylinder removed, disconnect vacuum hose from power brake unit. Remove pin connecting power brake unit operating rod to brake pedal assembly, remove nuts and remove power brake unit from vehicle.

**Installation** — Reverse removal procedures and note the following: Apply a suitable sealer to power brake unit mounting surface and vacuum line connections. Adjust pedal height and bleed hydraulic system.

## OVERHAUL

### BRAKE CALIPER

**NOTE** — Cylinders can only be overhauled one at a time, because with one piston removed air pressure is unattainable in second cylinder.

**Disassembly (All Models)** — With pads and piston retaining plates removed, clamp caliper (by mounting flange) in vise. Remove retaining ring and dust cover. Install suitable piston retaining tool (P83) to one piston and place a thin wood block between tool and piston to be removed. Apply air pressure to fluid inlet hole to remove piston. Remove cylinder to piston seal using a plastic or hard rubber tool. In addition to above disassembly procedure, proceed as follows:

- **924 & 928 Models** — Remove spring lock, retaining pin, spreader spring and inner brake pad. Remove sensor and outer brake pad. Press caliper frame off mounting frame. Drive brake cylinder off frame by tapping it lightly with a plastic hammer. Press piston out with compressed air. Remove seal.
- **911SC & Turbo Models** — Clamp caliper in vise and detach connecting line. Unscrew holding bolts, drive off

## PORSCHE (Cont.)

caliper halves from bridges by tapping with plastic hammer. Heat screws holding spring plate to 300°F (150°C), to prevent stripping of threads. Remove screws.

reassemble, install new "O" ring seals and reassemble caliper using new bolts, spring washers and nuts.

**NOTE** — Install shorter bolts in outside holes. Tighten two inside bolts first and then tighten outside bolts. Bolts must be tightened in two stages; first to 50% of torque value, then to 100% of torque value.

**Reassembly** — Reverse disassembly procedure and note the following: Use new rubber components, dust cover retaining ring and pad retaining plates. Apply brake cylinder paste to piston and cylinder seal. Assure piston is straight with cylinder by using a suitable piston installing clamp. Check 20° position of piston with suitable gauge and correct using piston rotating pliers (if required). On 911SC and Turbo models, apply Loctite before replacing spring plate screws. Replace seals on hollow bolt and adaptor.

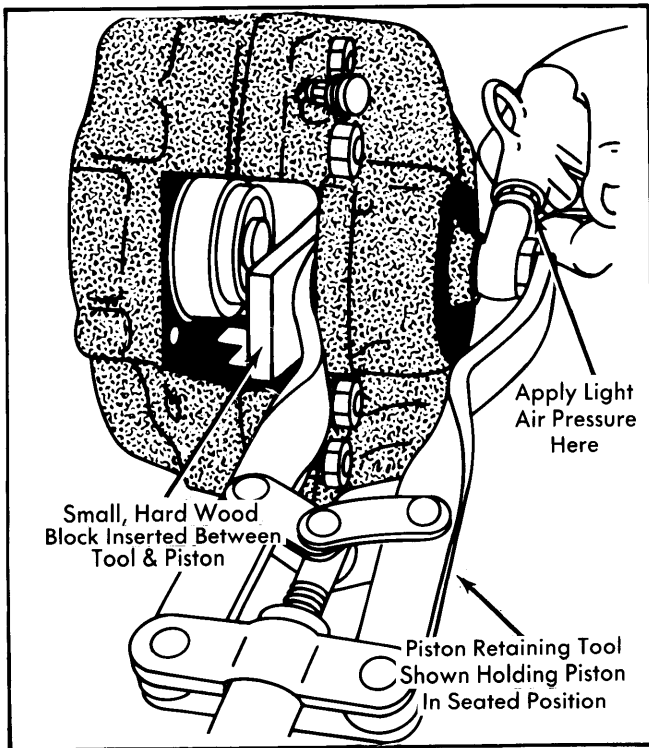

**Fig. 5 Using Air Pressure to Remove Piston from Caliper Assembly**

**Cleaning & Inspection** — Clean all parts in alcohol or clean brake fluid. Check all parts for wear or damage and replace as necessary. If caliper piston or bore show any signs of wear or damage, complete caliper assembly must be replaced.

**Separating Caliper Halves** — Caliper halves should only be separated if "O" ring seals between caliper halves show signs of leaking. To separate, remove bolts attaching caliper halves, separate caliper and discard "O" ring seals. To

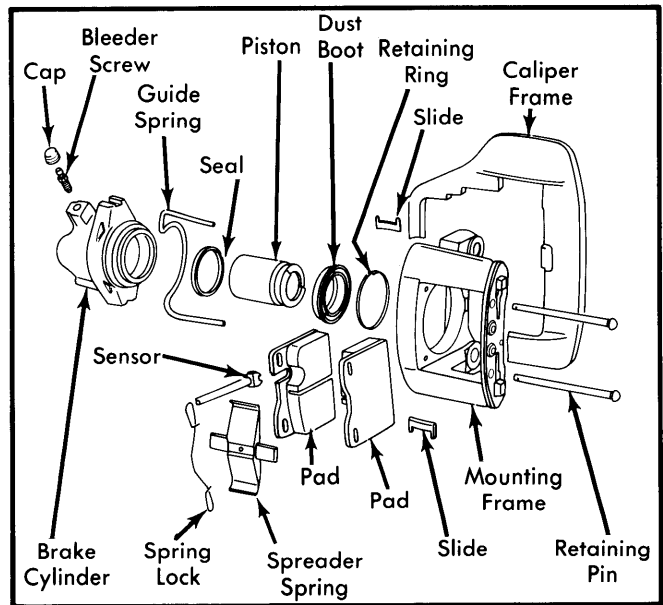

**Fig. 6 Exploded View of 924 & 928 Porsche Brake Caliper Assembly**

### DISC BRAKE ROTOR SPECIFICATIONS

Application	Disc Diameter In. (mm)	Lateral Runout In. (mm)	Parallelism In. (mm)	Original Thickness In. (mm)	Minimum Refinish Thickness In. (mm)	Discard Thickness In. (mm)
911SC & Turbo Models						
Front	11.97 (304)	.008 (.2)	.0012 (.03)	1.26 (32)	1.20 (30.6)	1.18 (30)
Rear	12.17 (309)	.008 (.2)	.0012 (.03)	1.10 (28)	1.05 (26.6)	1.02 (26)
924 Models						
Front	10.1 (257)	.....	.....	.51 (13)	.47 (12)	.45 (11.5)
928 Models						
Front	11.10 (282)	.004 (.1)	.0012 (.03)	.79 (20)	.75 (19.2)	.73 (18.6)
Rear	11.38 (289)	.004 (.1)	.0012 (.03)	.79 (20)	.75 (19.2)	.73 (18.6)

## PORSCHE (Cont.)

BRAKE SYSTEM SPECIFICATIONS				
Application	Drum Diam. In. (mm)	Wheel Cylinder Diameter		Master Cylinder Diameter In. (mm)
		Front In. (mm)	Rear In. (mm)	
924 Models	9.05 (230)	①	.75 (19.05)	.813 (20.64)

① — Disc brake caliper piston diameter should be 1.89" (48 mm).

### MASTER CYLINDER

**Disassembly** — Push in on primary piston to remove lock ring, then remove stop plate and primary piston assembly. Remove piston stop screw and, using compressed air, remove secondary piston. Remove secondary piston support washer, spring seat and return spring. To remove hydraulic warning system assembly, remove sending unit and retaining bolt from master cylinder, and using compressed air, remove pistons and springs.

**Cleaning & Inspection** — Clean all parts with alcohol. Check all pistons and cylinders for out-of-round, corrosion or damage. Inspect all other parts for scoring, excessive wear, corrosion or other damage.

**Reassembly** — To install reverse disassembly procedure using illustration as a reference and note the following: Lightly coat all parts with a suitable brake cylinder paste before installation. Use new "O" ring seals on warning system sending unit and retaining bolt. Tighten all brake lines and fittings and bleed complete brake system.

### TIGHTENING SPECIFICATIONS

Application	Ft. Lbs.
911SC & Turbo Models	
Master Cylinder Mounting Bolts .....	18 (2.5)
Brake Line Connections .....	10 (1.4)
Caliper Mounting Bolts (Front & Rear) .....	50 (7.0)
Caliper Housing Bolts, Front .....	43 (6.0)
Rotor to Hub .....	17 (2.3)
Splash Shield Bolts .....	18 (2.5)
924 Models	
Master Cylinder Mounting Bolts .....	9 (1.3)
Brake Line Connections .....	9 (1.3)
Caliper Mounting Bolts .....	60 (8.5)
Rear Brake Cylinder to Backing Plate Bolts .....	15 (2.1)
Rear Wheel Brake Drum Shaft Nut .....	220-290 (30-40)
928 Models	
Brake Line Connections .....	10 (1.4)
Master Cylinder .....	17 (2.3)
Caliper Bleeder Screw .....	2.5 (.35)
Caliper to Spindle .....	61 (8.5)
Caliper to Hub Carrier .....	61 (8.5)
Splash Shield to Spindle .....	11 (1.5)
Ratchet to Parking Brake Lever .....	18 (2.5)