

TOYOTA POWER-ASSISTED RECIRCULATING BALL

Celica
Corona
Cressida
Supra
4 x 4 Pickup

DESCRIPTION

POWER STEERING PUMP

The power steering pump is a vane type composed of an engine driven eccentric rotor, a fixed ring (having six slotted grooves), and a flow control valve (to regulate maximum oil pressure and amount of oil flow). Slippers are fitted in each slotted groove and are pressed against rotor outside surface by pressure produced in adjoining slots and by spring tension. As rotor rotation increases or decreases, then space between the rotor and fixed ring changes accordingly, in order to control oil flow.

POWER STEERING GEAR

Power steering gear consists of a mechanism which converts steering wheel torque to cross shaft torque by means of worm and power piston nut, and of a mechanism which detects hydraulic pressure developed by vane pump and controls this pressure in proportion to the steering effort. The worm shaft is separated at the center and power is transmitted from the steering wheel to worm gear through a small diameter torsion bar.

GENERAL SERVICE

HYDRAULIC SYSTEM LUBRICANT

Capacity — 1.7 pts.

Type — ATF Dexron

BELT TENSION ADJUSTMENT

With 22 lbs. (10 kg) pressure applied, belt deflection between idler pulley and vane pulley is .3-.5" (7-12 mm) for Cressida; .35-.40" (9-11 mm) for Pickup and .30-.35" (7-9 mm) on all other models.

STEERING GEAR AIR REMOVAL

1) Jack up front of vehicle and support with safety stands. Fill fluid to proper level in vane pump reservoir (turn wheels fully in both directions and recheck fluid level).

2) Start engine and let idle. Turn steering from lock to lock 2 or 3 times. Lower vehicle. Run engine at 1000 RPM or less. Turn wheel from lock to lock 2 or 3 times. Center steering wheel. If fluid level does not rise and no foaming of fluid is evident, bleeding is complete. If level rises, or foaming is evident, repeat procedure until air is released.

FLUID REPLACEMENT

Raise and support front of vehicle. Disconnect return hose and drain fluid into container. Turn steering wheel from lock to lock while draining. Connect return hose, add fresh fluid and bleed system.

HYDRAULIC PRESSURE TESTING

1) Disconnect pressure lines from steering gear case and vane pump. Attach pressure gauge with gauge side connected to vane pump. Attach valve side of gauge to pressure line. Bleed air from system and check fluid level.

2) Set engine idle speed. Check fluid pressure reading with pressure gauge valve closed. Correct pressure should be 881 psi (62 kg/cm²) on Pickup and 1022 psi (72 kg/cm²) on all other models.

NOTE — Do not keep pressure gauge valve closed for more than 10 seconds. Fluid testing temperature should be 176°F (80°C).

3) Open pressure valve. With steering wheel at full lock position, check oil pressure. Correct pressure is 881 psi (62 kg/cm²) on Pickup and 1022 psi (72 kg/cm²) on all other models. Measure oil pressure with engine at 1000 RPM and again at 3000 RPM. Pressure difference should be less than 71 psi (5 kg/cm²) on all models. If pressure is more, check flow control valve.

4) With vehicle on flat surface, turn steering wheel to midpoint. With engine idling, measure steering power at steering wheel circumference over one turn to full lock (both sides of midpoint). Left and right steering effort should be 7.7 lbs. (3.5 kg) on Pickup and 8.8 lbs. (4 kg) on all other models, maximum.

REMOVAL & INSTALLATION

POWER STEERING PUMP

Removal — Loosen pulley mounting nut before loosening drive belt. Disconnect and plug feed line and return line from pump housing. Remove pump assembly from mounting bracket and adjusting strap.

NOTE — Keep disconnected hoses elevated to prevent fluid from draining out.

Installation — To install, reverse removal procedure and note: Adjust drive belt tension and bleed system.

POWER STEERING GEAR

Removal — Disconnect pressure feed hose and return line from steering gear housing. Mark coupling and worm shaft for reassembly reference and remove coupling bolt and yoke. Mark pitman arm and cross shaft for reassembly reference. Remove pitman arm nut and pitman arm with suitable remover. Remove steering gear mounting bolts and housing.

Installation — To install, reverse removal procedure and note: Align all marks during installation. Bleed system and perform pressure test.

Power Steering

TOYOTA POWER-ASSISTED RECIRCULATING BALL (Cont.)

OVERHAUL

POWER STEERING PUMP

Disassembly — 1) Attach pump to suitable holding tool and mount tool in a vise. Mark front and rear housings for reassembly reference. Remove front housing bolts. Tap rear housing off with soft hammer. Do not allow shaft to come out; slippers and springs will fall out.

2) Remove rotor shaft, slippers and springs. Remove fixed ring from housing with soft hammer, being careful not to tap flow control valve. Remove flow control valve screw, locking plate and snap ring. Reinstall screw and grip with pliers to remove flow control valve. Remove side plates and "O" rings from front and rear housings.

NOTE — Do not drop, scratch or nick control valve.

Cleaning & Inspection — 1) Clean all parts in solvent and blow dry. Inspect oil seal lip and bushing sliding surface for wear or damage. Check rotor outer surface for wear or scoring. Inspect rotor-to-side plate contact surface.

2) Measure overall length of rotor (between end faces) and overall length of fixed ring. If overall length of rotor is more than .0024" (.06 mm) shorter than fixed ring overall length, replace with new rotor shaft sub-assembly.

3) Inspect slipper for wear: Measure length and thickness. If thickness is less than .0551" (1.4 mm) or if length is less than 1.571" (39.920 mm), replace entire set.

4) Inspect front and rear housing bushings. Bushing-to-rotor shaft clearance must not exceed .0012" (.03 mm). Inspect internal surface of fixed ring. If worn, scratched, or scored, replace ring. Check front and rear side plates at sliding surfaces. Bushings cannot be replaced separately. Replace entire housing.

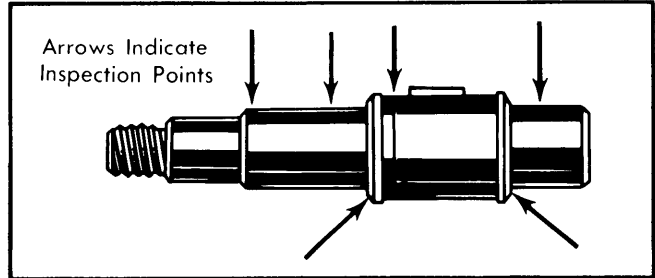

Fig. 1 Rotor Shaft Sub-Assembly Inspection Points

5) Measure free length of slipper compression springs. If less than .51" (13 mm) replace individually. If free length varies more than .02" (0.5 mm) between springs, replace entire set.

6) If flow control valve is scratched or otherwise damaged, replace it with one having the same production number. Measure compression spring for flow control valve. If free length measures less than 1.85" (47 mm), replace spring. Inspect ball and relief spring.

NOTE — Fixed ring, rotor shaft and slipper must be installed with matching production numbers.

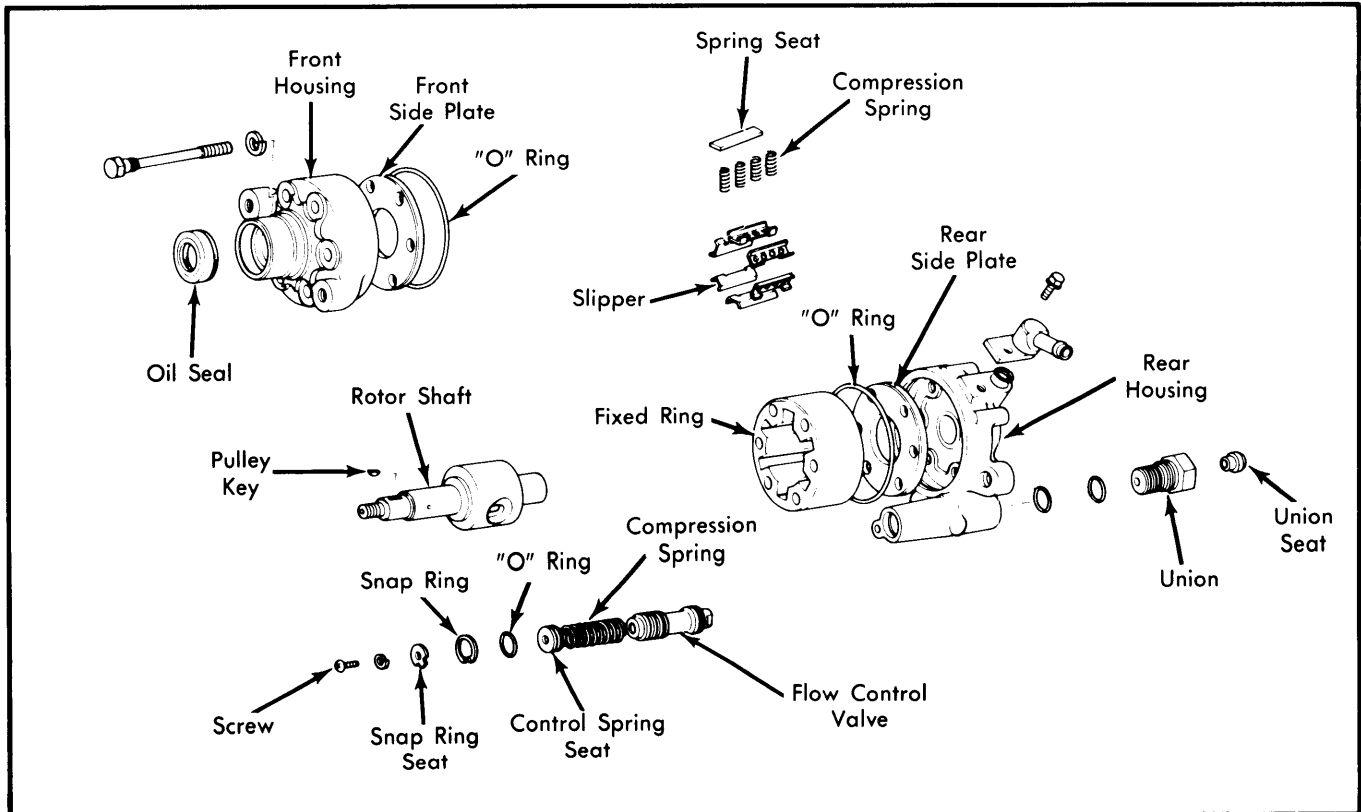

Fig. 2 Exploded View of Toyota Power Steering Pump Assembly

TOYOTA POWER-ASSISTED RECIRCULATING BALL (Cont.)

7) Inspect reservoir for leakage. Inspect "S" type oil seal and replace if damaged by removing with screwdriver. Apply a suitable lubricant to lip of new seal and install using special tool 09630-30041.

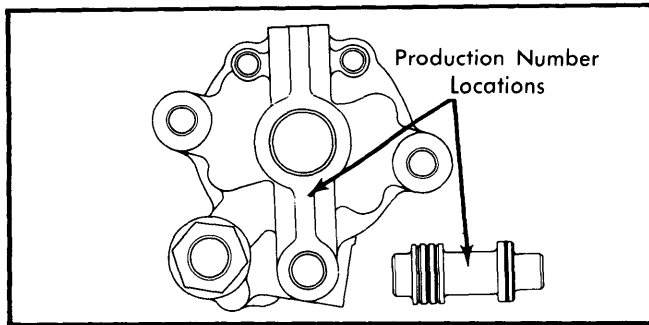

Fig. 3 Flow Control Valve and Rear Housing Production Number Locations

Reassembly — 1) Replace all "O" rings. Unless otherwise noted, coat all sliding surfaces and "O" rings with power steering fluid. Ensure that number on flow control valve matches number scribed on rear housing. Install flow control valve assembly. Check operation of valve by pushing into bore with finger.

2) Install side plate with large beveled width facing rear housing. Drive in fixed ring evenly with soft hammer. Lubricate and install rotor into rear housing. Assemble spring seat, springs and slipper. Install slipper assembly with open side facing counter clockwise.

3) Install second side plate with large beveled side facing front housing. Fit front housing over shaft assembly and align marks. Tighten front housing bolts evenly 3 or 4 times to specifications. Mount pulley on rotor shaft and check preload. Preload, while turning, should be less than 6.2 lbs (2.8 kg).

POWER STEERING GEAR

NOTE — It is recommended that Toyota tool kit part number 09630-22010 be used in disassembling and assembling power steering gear.

Disassembly — 1) Attach gear housing to holding tool and mount in vise. Tighten adjusting screw until end cover "O" ring is removed. Remove cross shaft by tapping bottom end with soft hammer. Remove bolts attaching gear housing to valve housing.

2) Hold power piston nut with hand and turn worm shaft clockwise (counterclockwise on Celica). Remove valve assembly and power piston.

CAUTION — Ensure that power piston nut does not come off worm shaft. Do not disassemble valve body or remove power piston from worm shaft.

3) Install valve assembly in vise. Using a dial indicator measure ball clearance. If clearance exceeds .006" (.15 mm) replace valve assembly.

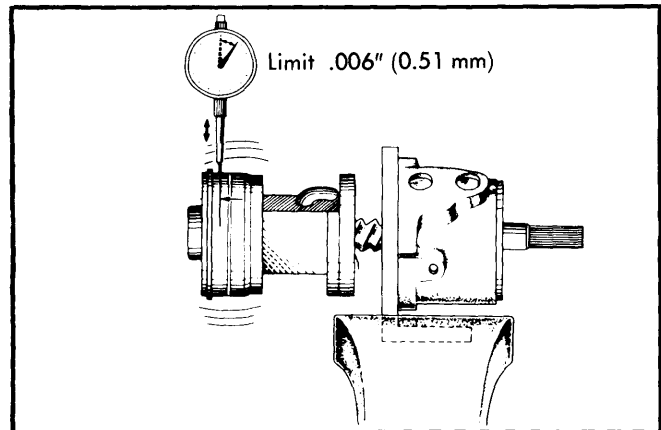

Fig. 4 Using Gauge to Check Ball Clearance

4) Install cross shaft in vise. Using dial indicator, check cross shaft adjusting screw for thrust clearance .001-.002" (.03-.05 mm). To adjust thrust clearance, remove seal from shaft. Using lock nut tool, loosen lock nut and turn adjusting bolt to set clearance. Install seal on cross shaft.

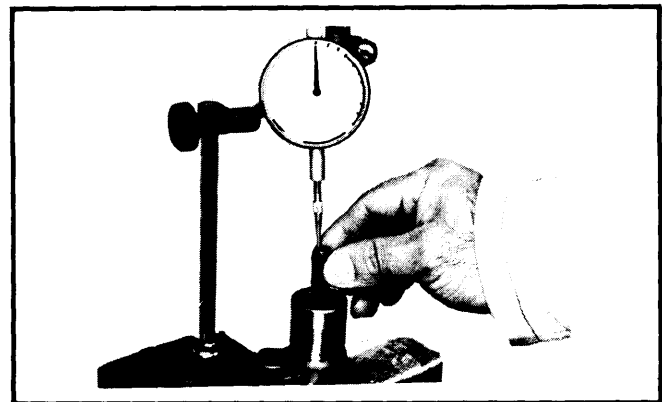

Fig. 5 Checking Thrust Clearance

5) Temporarily install valve assembly in gear housing and install mounting bolts. Using lock nut tool, remove lock nut and adjusting bolt from gear assembly. Remove and replace as needed, oil seal, "O" ring, and bearing assembly. Install lock nut and tighten. Remove valve assembly from gear housing.

Cleaning & Inspection — 1) Clean and dry all parts in solvent. Coat all sliding parts, "O" rings and teflon rings with power steering fluid upon reassembly.

2) Inspect cross shaft for peeling or pitting at ball rolling surface. Check power piston nut mesh with cross-shaft. Look for damaged tooth surfaces or ball rolling surfaces.

3) Gear housing bearings must be replaced if bearing rollers are pitted or peeled. Also replace housing bearings if it was noticed that cross shaft bearing surfaces had been scored or pitted.

4) Remove teflon ring and "O" ring from gear housing. Using needle bearing removing tool, remove needle bearings.

Power Steering

TOYOTA POWER-ASSISTED RECIRCULATING BALL (Cont.)

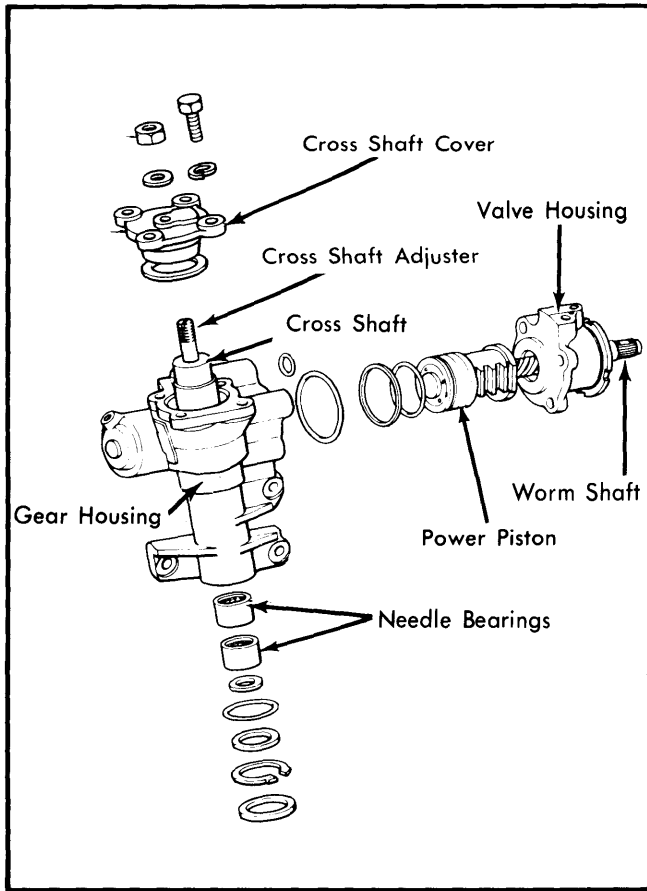

Fig. 6 Exploded View of Power Steering Gear
 (4 x 4 Pickup Gear Has Different External Design)

Reassembly — 1) Install needle bearings with longer edge of outer race facing outwards and ensure bearing top end aligns with housing end surface. Install lower bearing so that it is positioned .93" (23.6 mm) on Pickup and .76" (19.4 mm) on all other models away from housing inner end surface.

2) Install "O" ring, teflon ring and spacer in gear housing. Install "O" ring, valve housing, and mounting bolts. Tighten bolts to specifications. To adjust preload on worm shaft, loosen lock nut and install shaft tool and torque wrench on shaft. Preload should be 3.5-5.6 INCH lbs. (4-6.5 cmkg). Hold power piston nut to prevent it from turning.

3) Insert shaft holding tool inside of lock nut tool and tighten lock nut on worm shaft. Wrap a piece of vinyl tape around spline area of cross shaft. Align shaft gear with power piston nut gear and insert cross shaft in gear housing.

CAUTION — Do not turn cross shaft, because of possible damage to "O" ring.

4) Insert cross shaft (with cover attached) into housing and install mounting bolts. Tighten bolts to specifications. To adjust preload of cross shaft, set worm shaft to midpoint position. Determine total number of shaft turns and return from full lock by half that number.

5) Install shaft tool over shaft and attach a torque wrench. Using a screwdriver turn cross shaft adjusting bolt to specified preload; worm shaft preload plus 1.8-2.6 INCH lbs. (2-3 kg/cm²) on Pickup and 2.6-3.5 INCH lbs. (3-4 kg/cm²) on all other models.

6) Recheck worm gear preload to see that both right and left rotations are identical. Stake worm gear lock nut at three points.

TIGHTENING SPECIFICATIONS

Application	Ft. Lbs. (mkg)
Hose Union-to-Pump Housing	
Return Hose	24-30 (3-4)
Pressure Hose	29-36 (4-5)
Rear Reservoir Bolts	3-5 (0.4-0.7)
Worm Bearing Adjusting	
Screw Lock Nut	29-40 (4.0-5.5)
Cross Shaft End Cover	29-40 (4.0-5.5)
Valve Housing-to-Gear Housing	29-40 (4.0-5.5)
Gear Housing-to-Frame	36-51 (5-7)
Cross Shaft-to-Pitman Arm	
Pickup	116-137 (16-19)
All Others	80-101 (11-14)
Pulley-to-Pump	25-39 (3.5-5.4)
Pitman Arm-to-Relay (Corona)	37-50 (5-7)