

Power Steering

SAAB POWER-ASSISTED RACK & PINION – 900

900

DESCRIPTION

Power steering is available as optional equipment. The assembly consists of a rack and pinion steering gear with a servo valve which regulates the oil flow to a servo plunger on the rack. The hydraulic pressure is generated by an oil pump which is driven by a belt attached to the crankshaft pulley. The pump is integrated in a steel container that also serves as the hydraulic reservoir. In addition to pump unit itself, the pump also contains a control valve which regulates the pressure and flow.

REMOVAL & INSTALLATION

Removal – 1) Clean areas around hydraulic connections and disconnect return and pressure lines from steering gear. Plug lines and steering gear to prevent dirt from entering system. This will also prevent fluid from draining out.

2) Remove steering gear-to-intermediate shaft clamp bolt. Raise and support vehicle. Remove front wheels. Separate tie rods from steering knuckles.

3) Remove steering gear attaching bolts. Separate steering column (intermediate shaft) joint from steering gear, lift steering gear to the side and remove by guiding it diagonally downwards through opening in engine compartment.

Installation – Installation is a reversal of removal procedure; however, tie rod ends are to be connected after gear assembly has been fully installed. Adjust toe-in.

OVERHAUL

POWER STEERING GEAR

Disassembly – 1) With steering gear removed from vehicle, remove lock nuts and tie rod ends. Remove rubber bellows and breather tube. Remove hydraulic lines from steering valve and steering housing. Remove lock nut, adjusting nut, spring and piston from steering housing.

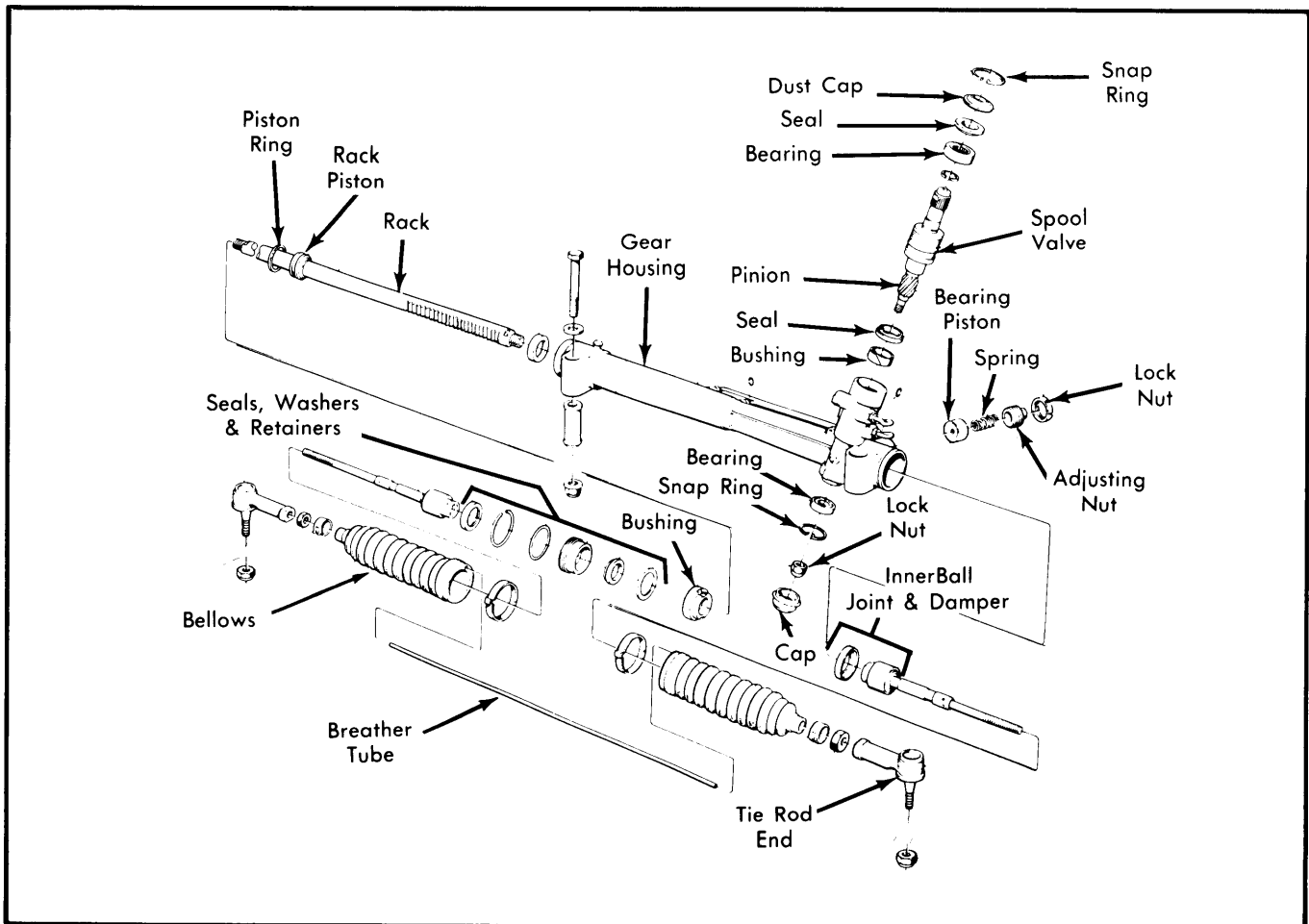

Fig. 1 Exploded View of Saab 900 Power Steering Components

SAAB POWER-ASSISTED RACK & PINION – 900 (Cont.)

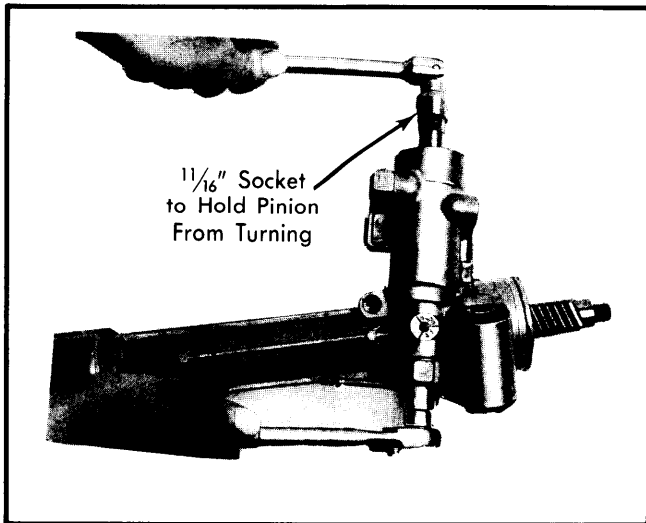

Fig. 2 Removing Pinion Lock Nut from Pinion Gear and Spool Valve

NOTE – Tapping steering housing lightly against wooden block will aid in removing bearing piston.

2) Remove pinion dust cap. Hold pinion from rotating (1 1/16" socket will fit splines of pinion) and remove pinion lock nut. Remove dust cover lock ring from (upper) pinion. Press pinion (with spool valve) out of steering gear. The bearing, support, seal, and dust cover seal will come out with the pinion.

NOTE – Do not use a hammer to remove pinion or damage to pinion, spool valve or housing could result.

3) Remove inner ball joint furthest from pinion by clamping rack in a soft jawed vice. Push plastic sleeve out of way and

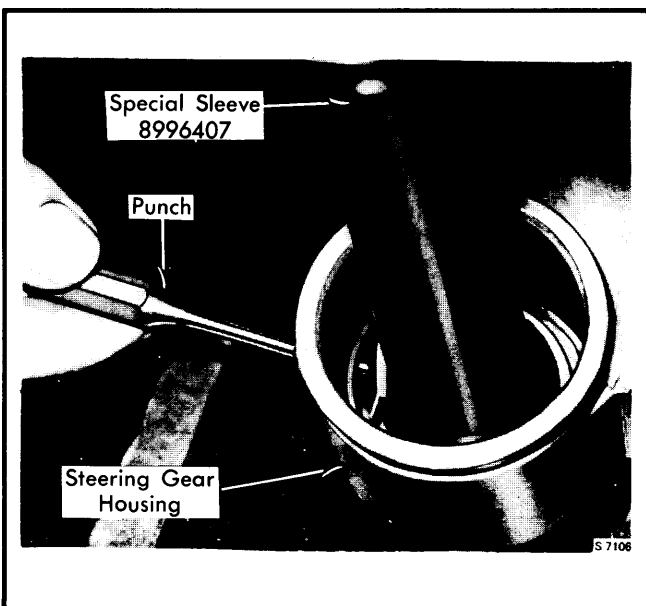

Fig. 3 Removing Wire Lock Ring from Steering Gear Housing

unscrew ball joint. Remove lock ring in end of gear housing as follows: Push rack into gear housing as far as it will go, install special sleeve (8996407) over rack and use inner ball joint (tighten) to press seal housing in. Then, use a punch to depress wire end of locking ring. Pry out ring with two screwdrivers. With ring removed, remove ball joint and special sleeve (8996407).

4) Remove ball joint nearest pinion as other ball joint was removed. Press out rack together with seal, washer and bushing. Remove seal and bushing from rack. Make sure there are no burrs on rack to damage seal or bushing before removing.

5) Remove inner rack using special tool (8996399) and a long punch or rod. Insert tool lips under seal, then from other end of housing insert long rod and drive seal out. Remove lock ring and lower pinion bearing. Remove sealing ring and bushing from top of pinion housing.

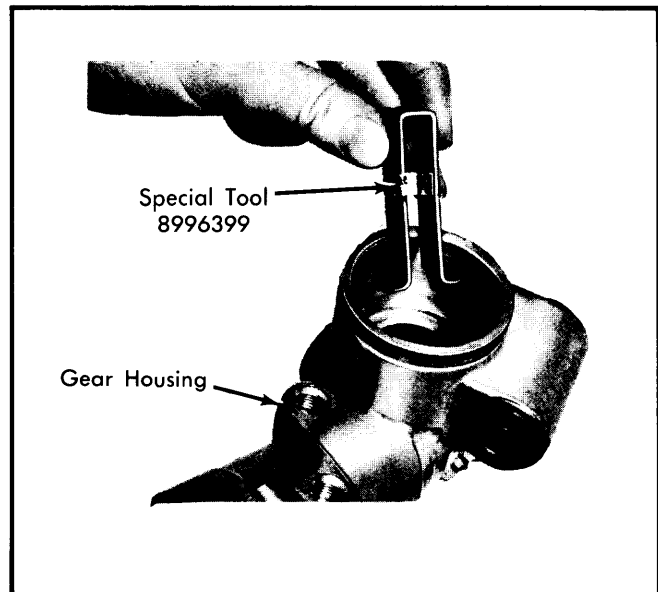

Fig. 4 Removing Inner Rack Seal Using Special Tool and Long Rod

Reassembly – 1) Lubricate pinion gear, rack teeth, bearings and dust cover seal with lithium grease. Lubricate all hydraulic parts with power steering fluid. DO NOT use ATF fluid.

2) Install lower pinion bearing (enclosed side of bearing facing downward) and lock ring (with chamfer on lock ring facing outwards). Install upper pinion bushing and hydraulic seal into pinion housing of gear housing using special tool (8996407). Install rack inner hydraulic seal onto rack. Use a thin plastic sheath or metal foil to cover rack teeth to protect sealing lip of seal.

3) Install rack into housing. Install inner hydraulic seal into housing using rack piston as a press. Do not use more than 500 lbs. (227 kg) force. Install bushing in gear housing (smaller

SAAB POWER-ASSISTED RACK & PINION – 900 (Cont.)

bore facing in), then washer against bushing. Install new "O" ring on outer hydraulic seal support. Install old seal (if not damaged).

4) Slide sealing ring support carefully onto rack to avoid damaging sealing lip. Press sealing ring support into housing using suitable sleeve (8390148). Center rack so same amount extends from each end of housing. Rotate rack so that rack teeth will mesh with pinion gear teeth when it is installed.

5) Install pinion gear and spool valve in gear housing as follows: Hold pinion gear (with spool valve) so groove in end of shaft (for tensioning screw) points toward the left (9 o'clock

position) when the pinion teeth engage the rack teeth. Insert pinion. Pinion should rotate so that groove in end of pinion points toward front (12 o'clock position) with rack centered. See Fig. 5.

6) Install pinion lock nut and tighten. Install cover. Install washer, needle bearing, sealing ring, dust cover and lock ring onto top of pinion gear (spool valve). Protect seal lips with tape or plastic sleeve over splines of pinion.

7) Install bearing piston, spring and adjusting nut in gear housing. Tighten adjusting nut until bearing piston firmly contacts rack, then back off adjusting nut 30-50°. Install and tighten lock nut.

8) Install plastic sleeves (endstops) and inner ball joints, with tie rods, to rack ends. Hold rack in soft-jawed vice and tighten ball joints. Lock inner ball joints by tapping tab on ball joint into rack.

9) Install lock ring for sealing ring support in end of gear housing. Turn pinion until inner ball joint presses against sealing ring support. Press in support and, at same time, install sealing ring in groove with thin screwdriver. Install rubber bellows, breathing tube and hydraulic lines.

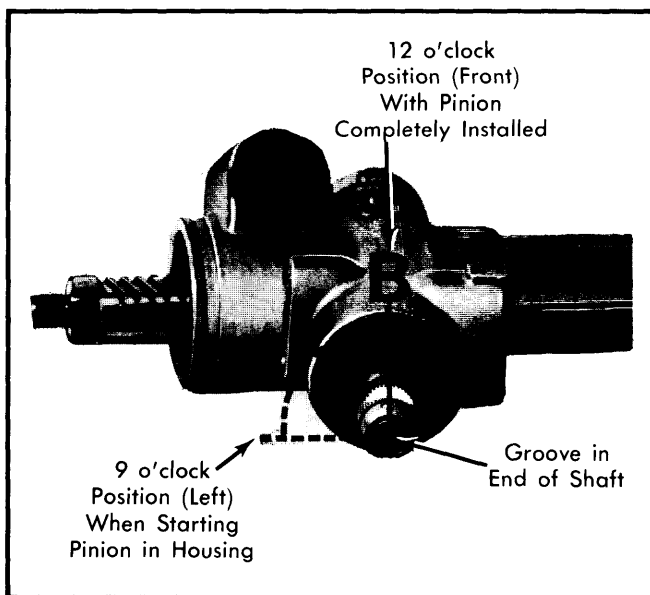

Fig. 5 Installing Pinion Gear (with Spool Valve) Into Gear Housing with Rack Installed

TIGHTENING SPECIFICATIONS

Application	Ft. Lbs. (mkg)
Hydraulic Lines	15-25 (2.0-3.4)
Ball Joint-to-Steering Arm	37-44 (5.0-6.0)
Pinion Gear Lower Lock Nut	22-34 (3.0-4.5)
Bearing Piston Lock Nut	48-55 (6.5-7.5)
Inner Ball Joint-to-Rack	59-72 (8.0-10.)
Gear Housing-to-Crossmember	44-60 (6.0-8.0)