

AUDI FOX RACK & PINION

Fox

ADJUSTMENT

RACK ADJUSTMENT

Loosen lock nut on steering gear cover. Hand tighten adjusting screw until it touches thrust washer. Hold screw in position and tighten lock nut. If steering is too tight or does not self center, readjust. If gear rattles when driven, adjustment is too loose.

CAUTION — Do not turn gear hard against either lock when vehicle is raised off ground or damage may result.

REMOVAL & INSTALLATION

STEERING GEAR

Removal — After removing both tie rod mounting bolts from rack, pry tie rods off steering gear. Remove lower instrument panel trim. Loosen bottom steering column mounting bolt and pry off clip. Drive bottom of column off gear, using a brass mandrel. Remove gear mounting bolts from body. Turn front wheels to right lock and remove steering gear through opening in right wheel well.

Installation — Before installing steering gear in vehicle, install the slider (in which both sealing sleeves are welded into the cup — see illustration). Install steering gear. To facilitate installation of tie rods, remove one bolt from the slider, install tie rod, and reinstall bolt. Repeat procedure for other tie rod. After tightening bolts, secure with lock plate.

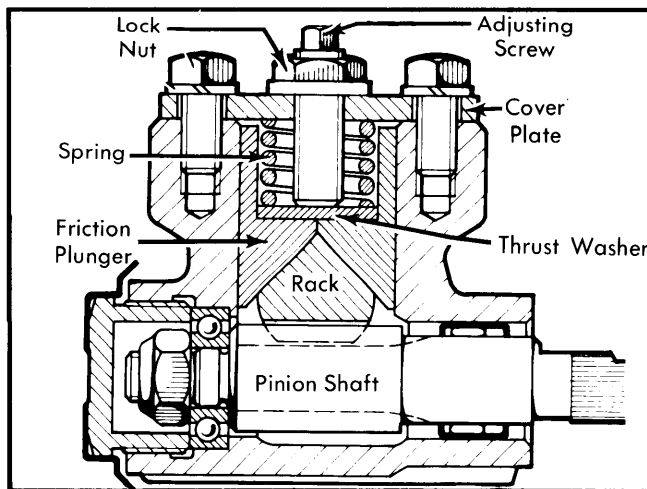

Fig. 2 Cross Sectional View of Pinion Shaft with Rack Adjustment

STEERING DAMPER

NOTE — Replacement of steering damper is the only service procedure recommended. Do not attempt repairs on this unit.

OVERHAUL

NOTE — Manufacturer does not recommend overhaul of this rack and pinion steering unit. If unit is determined defective, replace as assembly.

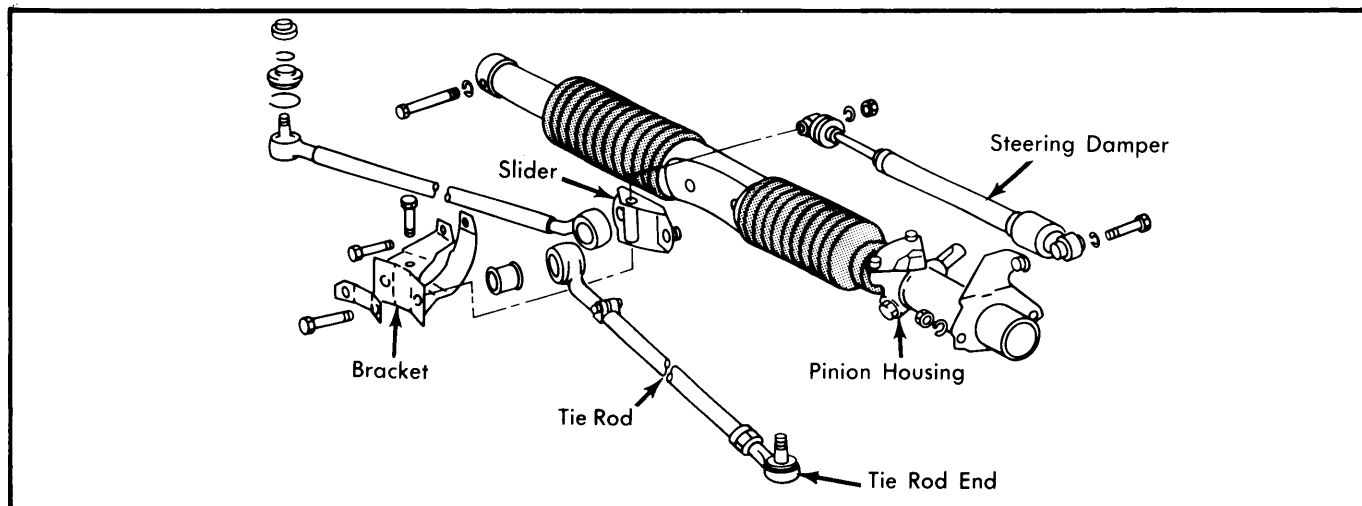

Fig. 1 Audi Fox Rack and Pinion Assembly