

Steering Columns

TOYOTA CELICA, CRESSIDA & PICKUP

Celica
Cressida
Pickup

DESCRIPTION

Passenger cars incorporate energy absorbing steering columns which collapse on impact. Steering shaft and column tube both telescope. Pickup steering shaft is solid and does not collapse. All columns attach to lower edge of instrument panel with a bolt-on bracket.

NOTE — For models with Tilt Wheel steering columns, see Tilt Wheel Steering Columns article in this section.

REMOVAL & INSTALLATION

NOTE — Removal and installation procedures are of a general nature and can be used for all models.

Removal — 1) Loosen pinch bolt (Fig. 1) attaching coupling yoke to worm shaft. Index mark coupling yoke and worm shaft. Loosen steering wheel nut and using a puller, remove steering wheel. For additional information, See Steering Wheel and Column Switches in STEERING Section.

2) Disconnect wiring harnesses for ignition switch, turn signals, horn, and dimmer switch. Remove switches. Unscrew column floor cover bolts. Remove lower instrument panel cover and air conditioning duct (if equipped). Remove bracket bolts and pull column out of vehicle.

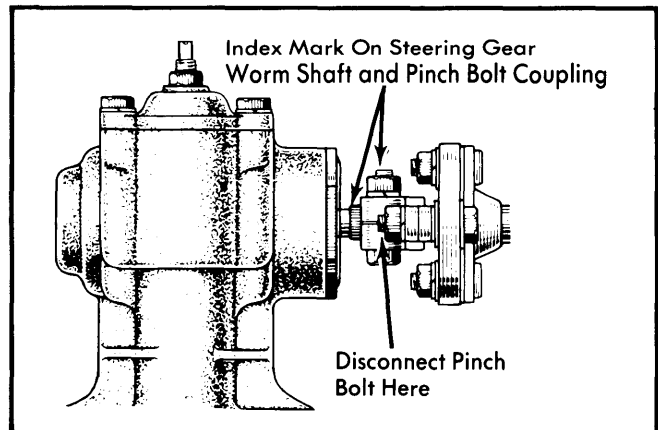

Fig. 1 Pinch Bolt Separation Point and Index Marking

Installation — 1) Insert steering column through column hole from inside of vehicle, align coupling yoke on steering worm, and tighten pinch bolt. **NOTE** — Yoke and worm are in proper alignment when yoke bolt hole is aligned with cut-away portion of worm spline.

2) Coat break-away bracket center portion with suitable weatherstrip adhesive. Finger tighten break-away bracket bolts. Tighten column hole cover bolts and break-away bracket nuts, then insert and tighten center bracket retaining bolt.

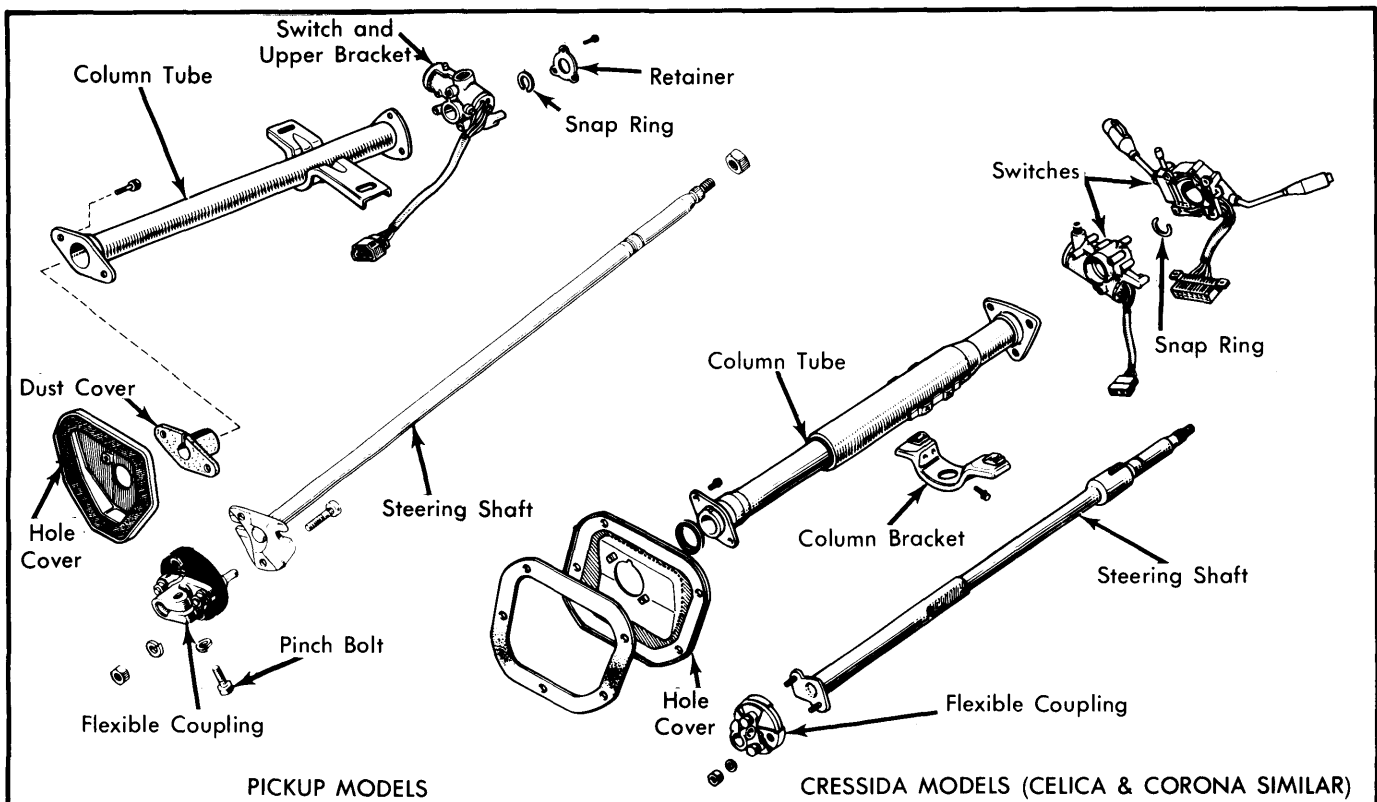

Fig. 2 Exploded View of Toyota Steering Columns (Except Tilt Wheels)