

MERCEDES-BENZ

240D
280 Series
300 Series
450 Series
6.9

DESCRIPTION

Steering column assembly includes an impact absorbing steering wheel, upper and lower column shafts and flexible coupling. Lower shaft on 123 Series models is corrugated for additional impact protection.

CHASSIS IDENTIFICATION

Application	Chassis Type
240D, 280E, 280CE, 300D, 300CD, 300TD	123
450SL, 450SLC	107
280SE, 300SD, 450SEL, 6.9	116

STEERING COLUMN

Removal - 1) On 123 Series, remove screws holding upper and lower cover on instrument panel and remove covers. On all models, disconnect battery and remove steering wheel. Remove instrument cluster by pulling outward as far as possible and loosening tachometer, temperature, and oil pressure connections.

2) On all models, remove steering lock. Disconnect wiring connectors. Remove Allen head screw of flexible coupling and all nuts and screws holding casing and column to dashboard. Remove steering column housing.

Installation - To install, reverse removal procedure. On 450 and 6.9 models, hold steering shaft in place with pin through hole in jacket tube. Check that lower tube on 123 Series is not bent or distorted. Use caution when installing jacket tube to prevent damage to this shaft.

STEERING COLUMN SHAFT

Removal, 123 Series (Lower) - 1) From engine compartment, remove both Allen head screws holding flexible coupling to worm shaft and steering shaft. Slide coupling down on worm shaft and off steering shaft.

2) From inside car, remove upper and lower cover from instrument panel/steering column. Remove Allen screws at upper coupling and slide coupling and lower shaft off of upper shaft.

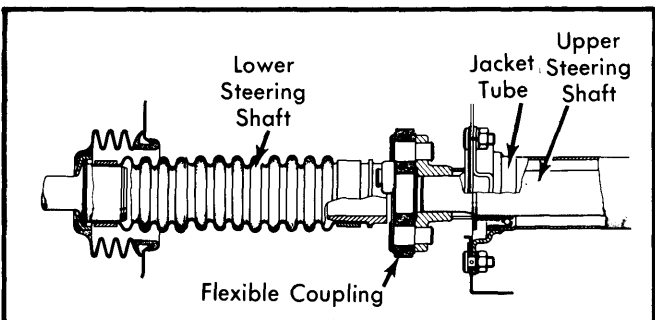

Fig. 1 Lower Steering Shaft (123 Models)

Installation - To install, lubricate inner lips of bellows seal at firewall and reverse removal procedures.

NOTE - Wheels must be in straight ahead position and notch on upper shaft must point directly upward during installation.

Removal, 123 Series (Upper) - 1) With column out of car, remove combination switch. Remove jacket tube casing, then remove spacing ring from steering shaft.

2) Remove gripper ring, compression spring, supporting ring and ball bearing from steering shaft. Knock steering shaft upward out of jacket tube with plastic hammer.

Installation - Inspect and replace bearings and races if required. Reverse removal procedure and reinstall upper steering shaft.

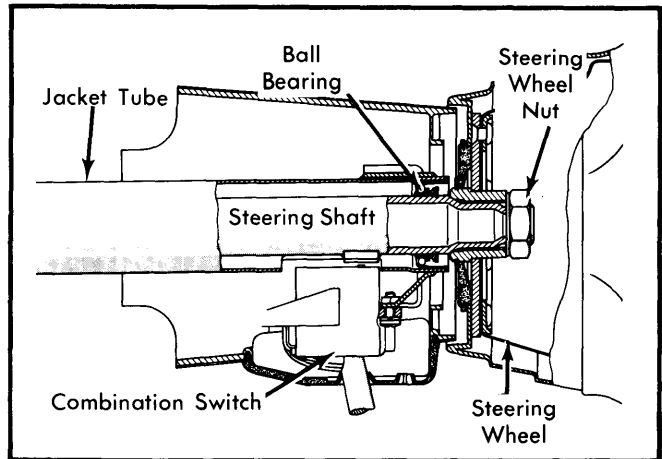

Fig. 2 Typical Steering Wheel and Shaft

Removal, 107 and 116 Series - 1) Remove steering wheel and combination switch rubber cover. Loosen switch mounting screws on bearing body and pull switch out slightly. Loosen screws holding cable of contact carbon on combination switch.

2) Remove Allen screw from upper end of steering coupling. Remove screws from jacket tube and pull steering shaft with bearing body out of jacket tube.

Installation - Replace bearings and races as required and reverse removal procedure. Check shaft adjustment; pin inserted through hole in jacket casing should locate check bore of steering shaft. Mark on end of shaft should be up when installing.

NOTE - Steering shaft length should be 31.7" (805 mm); tap gently with plastic mallet to adjust length before installation.

TIGHTENING SPECIFICATIONS

Application	Ft.Lbs. (mkg)
Steering Wheel	37 (5)
Jacket Tube-to-Cross Member	7 (1.0)
Jacket Tube-to-Lower Bracket	18 (2.5)
Flexible Coupling (Allen)	18 (2.5)