

Steering Columns

CHRYSLER CORP. IMPORTS – FRONT-WHEEL-DRIVE MODELS

Champ
Colt Hatchback

DESCRIPTION

Collapsible steering system is comprised of a two-piece (upper and lower) column shaft, joined by a collapsible (bellows type) section. The bellows section contracts axially under impact without affecting turning motion.

REMOVAL & INSTALLATION

STEERING COLUMN

Removal – 1) Remove steering column cover. Pull out column switch connectors, then pull switch out toward steering wheel end.

NOTE – When removing steering column as an assembly, leave all connector clamps intact.

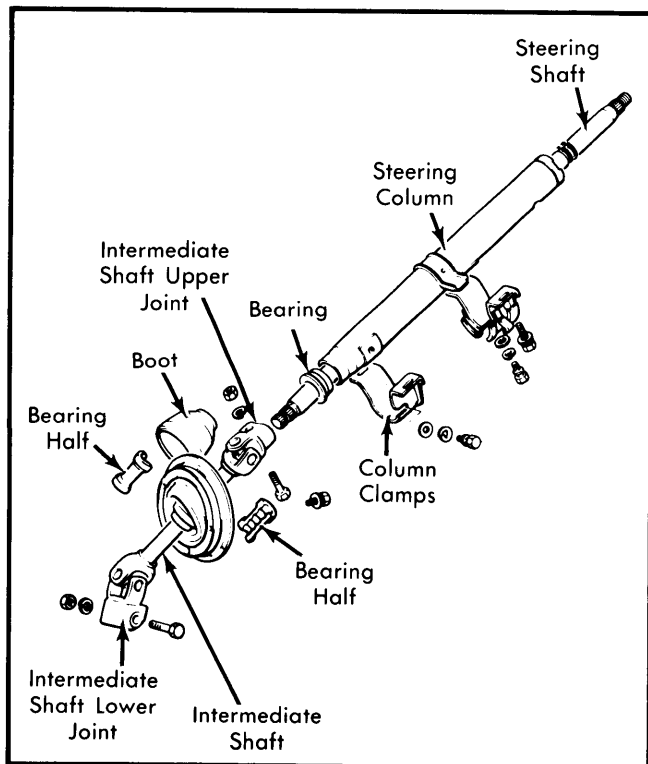

Fig. 1 Exploded View of Steering Column

2) Remove steering shaft upper coupling bolt. Remove bolts securing steering column brackets to frame. Disconnect steering shaft from coupling (inside vehicle) and remove steering column assembly.

3) Remove intermediate shaft lower coupling bolt (at steering gear). Remove dust cover mounting bolts. Remove intermediate shaft (with dust cover) toward inside of vehicle.

Installation – 1) Install dust cover to intermediate shaft. Make sure bearing side of cover faces steering shaft side of intermediate shaft. See Fig. 2 and 3.

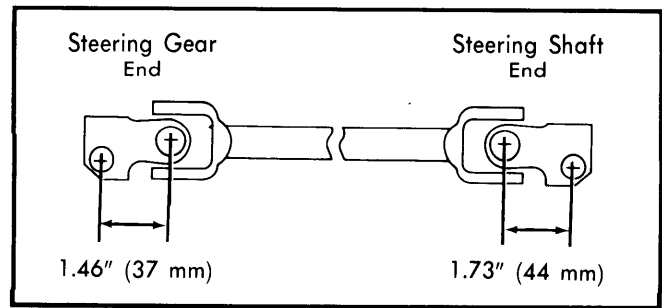

Fig. 2 Determining Correct Intermediate Shaft Installation Position

2) Apply grease to bearing and dust cover, then install bearing (two pieces) into dust cover. Attach intermediate shaft lower joint to steering gear and temporarily tighten dust cover bolts. Now tighten lower joint clamp bolt.

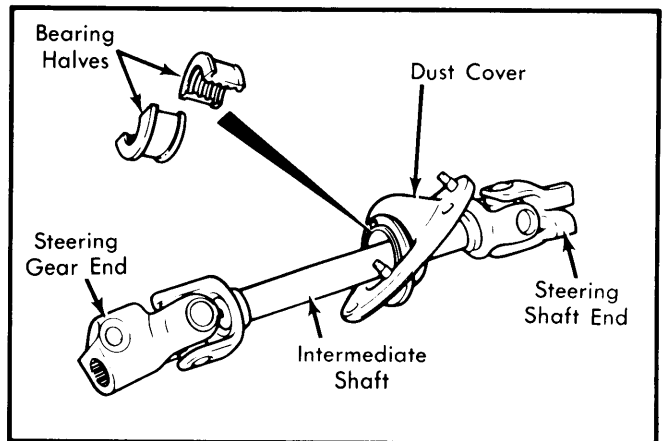

Fig. 3 Dust Cover and Bearing Installation

3) Connect intermediate shaft upper joint to steering shaft. Attach steering column brackets to dash. Tighten clamp bolt of intermediate shaft and column bracket bolts.

4) Loosen dust cover bolts and position dust cover so no clearance exists between joint and dust cover sliding surfaces. Tighten dust cover bolts. Adjust steering wheel position if necessary.

OVERHAUL

Disassembly – 1) Remove the two-piece bearing from dust cover of intermediate shaft. Remove dust cover from intermediate shaft.

2) Remove snap ring from steering shaft (steering wheel end). Unlock steering wheel lock (with ignition key), then remove steering shaft from column by lightly tapping shaft with soft (rubber or plastic) mallet.

3) If steering lock is to be removed, cut a slot in mounting screws with hacksaw. Use a flat blade screwdriver to remove screws then remove steering lock. Always use new screws and bracket when replacing steering lock.

CHRYSLER CORP. IMPORTS – FRONT-WHEEL-DRIVE MODELS (Cont.)

4) If steering column bracket is removed, cut a slot in mounting bolt with hacksaw. Remove bolts with flat blade screwdriver. Always use new bolts when installing bracket to steering column.

Inspection – Check steering shaft for runout and length. Runout should be .02" (.5 mm) or less, length should be 23.17" (588.5 mm). Check for a worn or damaged bearing. On intermediate shaft, check for play, noise or rough rotation in joints. Also check for a damaged dust cover. Replace components as required.

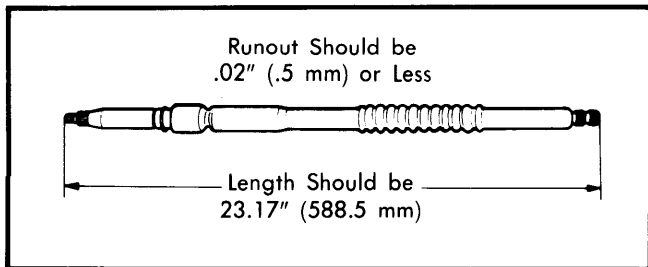

Fig. 4 Check Steering Shaft for Length and Damage

Reassembly – 1) Install steering shaft in steering column and install snap ring. Install and tighten column tube bracket bolt until bolt head snaps off.

NOTE – Torque needed to snap bolt head off should be approximately 9 ft. lbs. (1.2 mkg).

2) Fill bearing with grease and install in end of steering column. Make sure bearing is fully seated. Align steering lock with column boss. Make sure that steering lock is operational (by using ignition key to make lock function) before tightening lock securing screw.

NOTE – Steering lock securing screws are special one way design.

TIGHTENING SPECIFICATIONS	
Application	Ft. Lbs. (mkg)
Column Tube-to-Bracket Bolt	
Torque Required to Snap Head Off	9 (1.2)
Column Support Bracket Bolts	7 (1.0)
Clamp Joint Bolts	
Upper and Lower	11-14 (1.5-2.0)
Steering Wheel Nut	29-36 (3.9-4.9)