

AUDI 5000

5000

DESCRIPTION

The Audi 5000 uses a two-piece steering column/shaft assembly. The steering shaft is designed with an offset slip joint that engages the flange tube. In a collision, the gear box and flange tube may be moved rearward, but the force will not be transmitted through the upper column shaft. An anti-theft locking device prevents the steering wheel from turning when the ignition key is removed.

REMOVAL & INSTALLATION

Removal – 1) Disconnect battery ground wire and loosen flange tube-to-pinion shaft clamp bolt. Pull off horn pad by hand and remove steering wheel with suitable puller.

2) Insert screwdriver through access hole at bottom of switch cover and loosen clamp. Remove switch assembly and disconnect ignition switch wiring. Place ignition switch in "ON" position.

3) Centerpunch shear bolts holding steering lock. Drill out shear bolts. Remove switch and unbolt mounting flange from under dash. Remove steering column and shaft as a unit.

Disassembly – Remove retaining ring, spring and support ring. Pull steering shaft out of column from the bottom. If necessary, press bearing race out of column.

Reassembly – Examine race and replace if excessively worn. Slide steering shaft back into column tube, then replace support ring, spring, and use a new retaining ring to lock in place.

Installation – 1) Place column assembly in vehicle. Install steering lock shear bolts finger tight and check operation of lock. Bolt mounting flange onto bracket.

2) Connect ignition wiring. Install flange tube over steering column pins and press on pinion shaft. Hold flange tube and shaft together with pliers and check length of shaft protruding from upper end of column. Adjust by moving flange tube on pinion shaft until distance is 2.56" (65 mm). See Fig. 2.

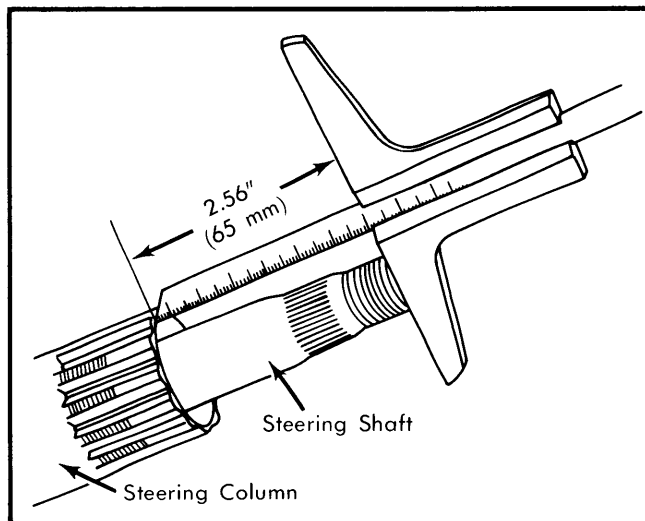

Fig. 2 Steering Shaft Installation Measurement

3) Tighten shear bolts until heads break. Install switch assembly flush with dashboard. With wheels in straight position, turn signal lever in middle position and cancelling lug to right, install steering wheel. Tighten steering wheel nut to 36 ft. lbs. (5 mkg). Gap between wheel and switch assembly should be 1/8" (3 mm). Adjust if necessary and tighten flange lamp bolt on pinion shaft.

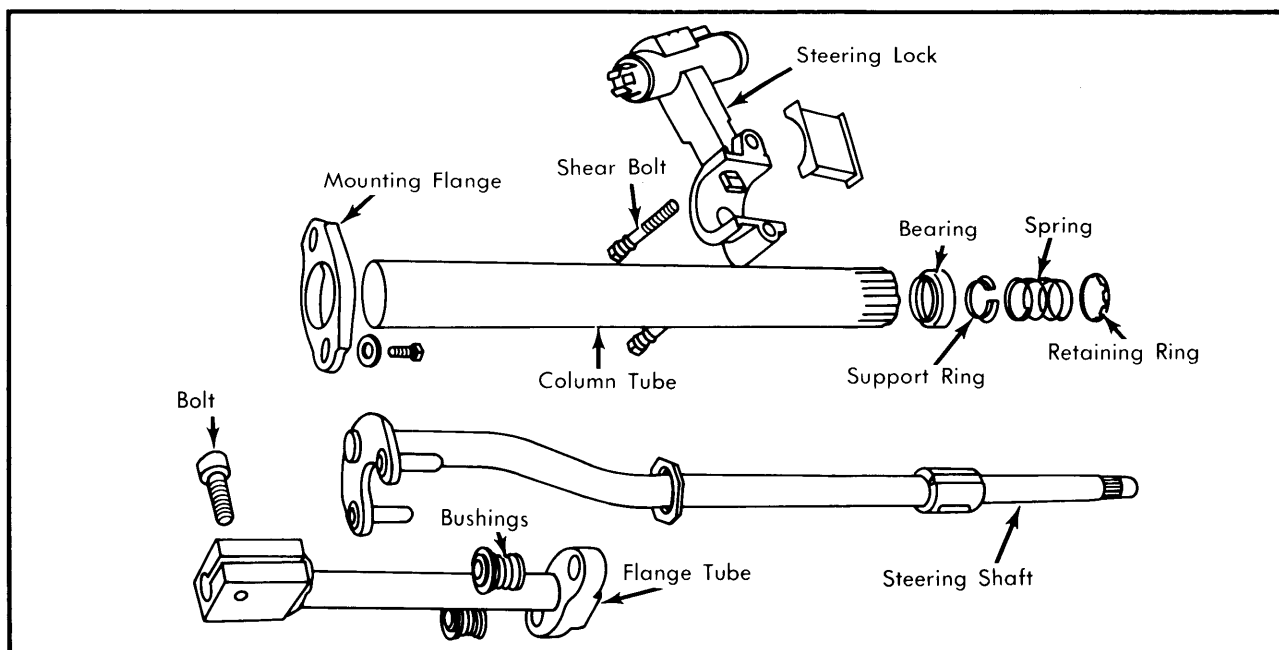

Fig. 1 Exploded View of Audi 5000 Steering Column