

# Steering Columns

## AUDI FOX

Fox

### DESCRIPTION

The Audi Fox uses a two piece safety steering column with a slip joint flange connection. A metal lattice column support is also used to help absorb shock in the event of a collision.

### REMOVAL & INSTALLATION

#### STEERING COLUMN

**Removal** - 1) Disconnect battery ground strap. Remove steering wheel. See Audi Fox under STEERING WHEELS & COLUMN SWITCHES in this Section.

2) Remove all steering column switches.

3) From under hood, remove pinch bolt holding steering column flange to pinion shaft.

4) Work under brake pedal and unbolt mounting flange from bracket. Disconnect electrical wires from ignition switch. Put ignition switch in "ON" position.

5) Centerpunch shear bolts holding steering lock on steering column. Drill out shear bolts. Remove steering lock. Remove steering column and shaft as a unit. It may be necessary to drive flange tube off pinion shaft with a drift.

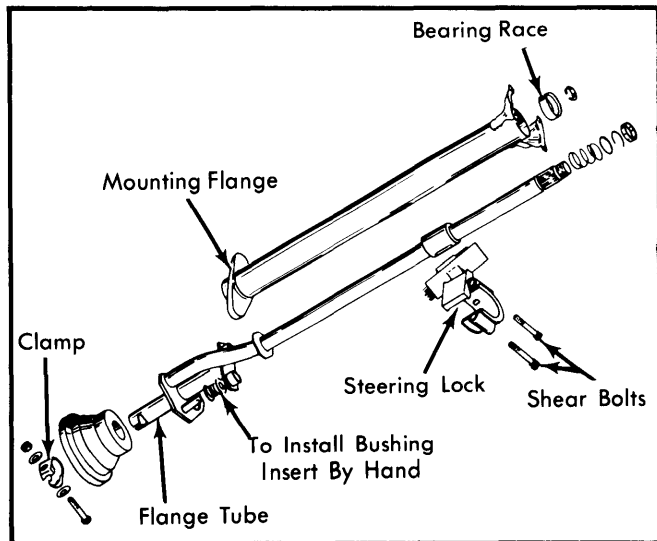

Fig. 1 Exploded View of Fox Steering Column

**Disassembly** - Pull off steering wheel spacer ring and snap ring. Remove flat washer and spring. Pull steering shaft out through bottom of column. Press race out of column.

**Reassembly** - Examine race and replace if excessively worn. Slide steering shaft back into column then refit spring and snap ring.

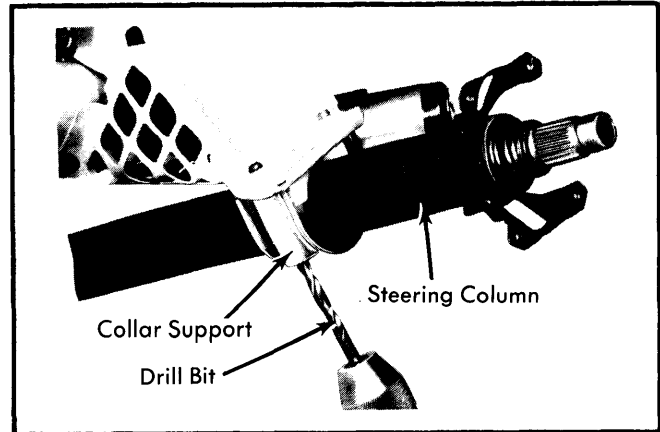

Fig. 2 Using a Drill to Remove Steering Column Shear Bolts

**Installation** - 1) Position column assembly back in vehicle. Install steering column lock. Make sure lock lug will snap into recess in steering column. Fit new shear bolts finger tight.

2) Bolt steering column mounting flange onto bracket so long side of flange faces right side of vehicle. Snug up flange bolts and shear bolts.

3) Connect electrical wires to ignition switch. Fit column trim. Place front wheels straight-ahead.

4) Make sure column bushings are in position on pins at lower end of steering column. Line holes in flange so flange will slide down over pins on steering column. It will be necessary to use drift to drive flange tube onto steering gear pinion shaft. Make sure flange seats to stop on pinion. Tighten pinch bolt.

5) Maneuver steering column until steering lock operates effectively. Tighten shear bolts until head snap off. Refit steering wheel.

### TIGHTENING SPECIFICATIONS

Application	Ft. Lbs. (mkg)
Steering Gear Box-to-Frame .....	14 (2.0)
Column Mounting Flange Bolts .....	7 (1.0)
Steering Wheel Nut .....	36 (5.0)
Gear Box Pinch Bolt .....	22 (3.0)