

RENAULT R-5

R-5

DESCRIPTION

System is torsion bar type with a trailing arm. Trailing arms are mounted off chassis and have torsion bars connected to in-board edge.

ADJUSTMENT

WHEEL ALIGNMENT SPECIFICATIONS & PROCEDURES

See *Wheel Alignment Specifications and Procedures* in *WHEEL ALIGNMENT* Section.

RIDING HEIGHT ADJUSTMENT

See *Riding Height Adjustment* in *WHEEL ALIGNMENT* Section.

REMOVAL & INSTALLATION

TRAILING ARM

Removal — Raise rear of vehicle and place on safety stands. Disconnect, then carefully remove sway bar. Remove shock absorber. Disconnect brake lines and plug openings. Put torsion bar adjusting cams in zero position. Remove torsion bars from both sides. Remove mounting bolts and slide complete arm assembly from vehicle.

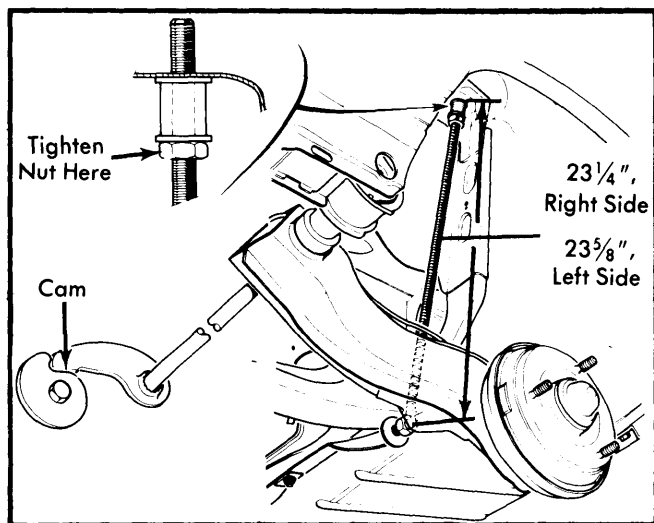

Fig. 1 Trailing Arm and Torsion Bar Assembly

Inspection — Check all bushings and spacers for obvious signs of wear or damage. Use suitable puller and/or mandrel (with press) to replace bushings.

Installation — To install, reverse removal procedure and note: Bleed brake system. Recheck brake pressure equalizer. Check rear wheel alignment.

TORSION BAR

Removal — Raise vehicle and place on safety stands. Loosen lock nut on cam and adjust until cam is zeroed. Remove shock absorber. Fit fabricated tool where shock absorber has been removed. Tighten nut until adjuster lever is raised from cam. Remove torsion bar.

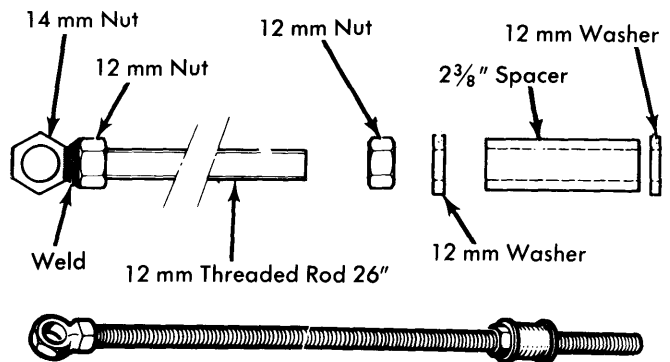

Fig. 2 Specifications for Tool Fabrication

NOTE — Before installing torsion bar, adjust nut on tool to $23\frac{1}{4}$ " (590 mm), right side and/or $23\frac{5}{8}$ " (600 mm), left side. This will allow torsion bar to be inserted.

Installation — Put adjuster lever so it touches cam. Lightly coat torsion bar splines with grease, then insert into lever and arm. Tighten cam lock nut. Take off tool. Install shock absorber. Lower vehicle. Measure under body (riding height).

SHOCK ABSORBER

Removal — Work from inside trunk and remove upper nuts. Raise vehicle and place on safety stands. Remove lower mounting nut and take off shock absorber.

Installation — To install, reverse removal procedure. Make sure upper mounting is attached first.