

Rear Suspension

JAGUAR

XJ6
XJ12
XJS

DESCRIPTION

Independent, coil spring type suspension. Outer bearing carrier and hub assembly is supported by control arms at bottom and utilizes drive axles as upper support. Suspension is controlled by two coil spring/shock absorber assemblies mounted at each rear wheel. Movement of lower control arms are controlled by radius arms connected to control arms at rear and to chassis members at front.

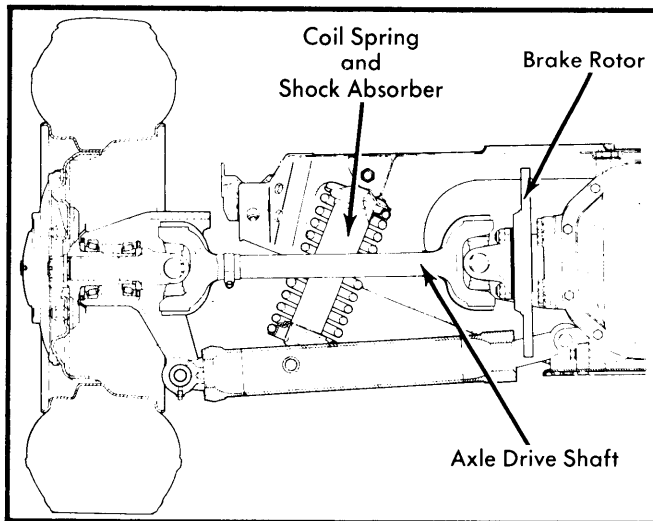

Fig. 1 Jaguar Rear Suspension Assembly

ADJUSTMENTS

WHEEL ALIGNMENT SPECIFICATIONS & PROCEDURES

See *Wheel Alignment Specifications and Procedures* in *WHEEL ALIGNMENT* Section.

REMOVAL & INSTALLATION

COIL SPRING & SHOCK ABSORBER

NOTE — Rear springs can be removed with rear suspension installed in vehicle.

Removal — Raise vehicle and support at lift points with jack stands. Position floor jack under control arm. Remove nut and bolt mounting top of shock absorbers to the suspension assembly crossmember. Remove washers and nuts securing shock absorbers to lower mounting. Using a drift, remove mounting piece. Withdraw shock absorber and coil spring assembly. Using a spring compressor, collapse spring until collets and spring seat can be removed. Release pressure and separate shock absorber from spring.

Installation — To install spring and shock absorber assembly, reverse removal procedure and tighten all nuts and bolts.

RADIUS ROD

Removal — 1) Raise and support vehicle on safety stands forward of radius rods. Remove tire and wheel. Remove bolt and spring washer securing safety strap to body. Remove lock wire and bolt securing radius rod to body, then remove safety strap.

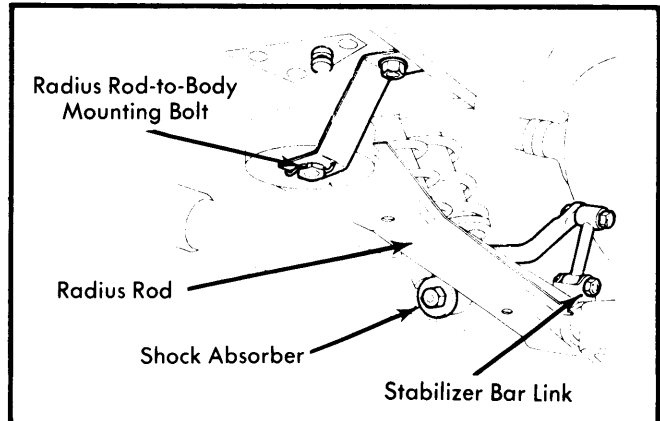

Fig. 2 Installed Position of Radius Rod

2) Remove forward lower shock absorber mounting pin. Using a punch, remove pin rearward. Bend tab washer and remove bolt mounting radius rod to control arm.

Installation — Replace any damaged radius rod bushings. When pressing bushings into radius rod, bushing should protrude from each side equal amounts. To install, reverse removal procedure.

REAR SUSPENSION ASSEMBLY

Removal — 1) Raise and support vehicle forward of radius rods. Remove tires and wheels. Place floor jack (with adaptor to hold suspension assembly) under rear suspension.

2) Disconnect intermediate exhaust pipes at both ends. On XJS models, remove rear mufflers.

3) On XJ12 and XJ6 models, remove intermediate exhaust pipe from vehicle. Block rear mufflers out of way.

4) Disconnect radius rod-to-body mounting hardware.

5) On XJS models, separate stabilizer bar from radius rods.

6) Separate brake line union from body bracket. Disconnect brake lines at flexible hoses and plug openings. Disconnect propeller shaft at differential. Lower shaft out of way.

7) Release parking brake. Separate actuating lever cable. Disconnect opposite side cable at trunnion and retain cable out of way.

8) On models equipped with overdrive units, disconnect speedometer and electrical wire.

9) On XJS models, remove bolts attaching suspension mounting rubbers to body.

JAGUAR (Cont.)

10) On XJ12 and XJ6 models, remove 8 self-locking nuts and bolts and 4 nuts keeping mounting brackets to body.

11) Lower suspension to ground and slide from vehicle. Guide intermediate exhaust pipe from suspension assembly.

Installation — Reverse removal steps and bleed brake system.

LOWER CONTROL ARM

Removal, XJ12 and XJ6 — 1) Drain differential. Remove suspension assembly as previously described. Place suspension on bench in an inverted state.

2) Remove 6 nuts mounting support plate to crossmember. Remove 8 bolts mounting support plate to lower control arm inner fulcrum brackets.

3) Remove fulcrum shaft and refit dummy shaft. Collect shims and oil seal retaining washers from each side of shaft. Remove lock nut from shock absorber fulcrum pivot and drift shaft rearward through control arm. Move shock absorber toward suspension middle.

4) Disconnect radius rod from control arm and remove shock absorber pivot assembly. Remove nut from lower control arm inner fulcrum shaft and tap shaft out. Guide control arm from vehicle.

5) Collect all thrust washers, seal retainers, seals, bearing tubes, needle bearings and spacer from each inner control arm boss.

Installation — 1) Lightly coat bearing cage with grease and press into inner fulcrum shaft boss. Stamped markings face outward. Insert bearing tube and press in other bearing. Repeat procedure for each boss.

2) Fit thrust washers to control arm. Insert control arm to inner fulcrum mounting bracket. Make sure radius rod bracket faces front of suspension.

3) Fit dummy shaft from each end to keep bearings and insert control arm with mounting bracket. Tap in fulcrum shaft.

NOTE — Be careful not to drop thrust washers off control arm.

4) Reverse removal procedure for installation of remaining components.

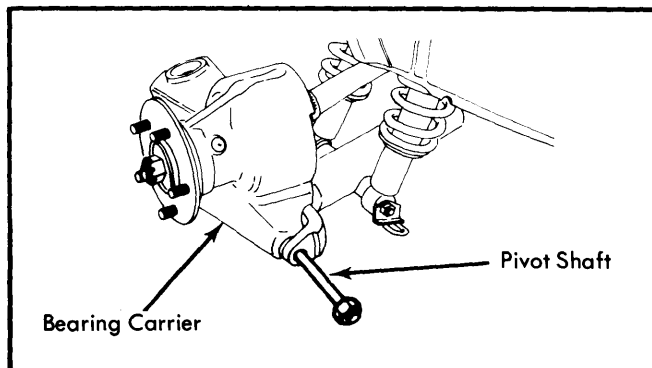

Fig. 3 Fitting Dummy Pivot Shaft

Removal, XJS — 1) Raise and support vehicle with stand placed ahead of radius rods. Remove tire and wheel.

2) Remove lock nut and drift out bearing carrier fulcrum shaft. Fit dummy shaft for support. Collect shims and oil seal retainers.

3) Lift bearing carrier up, clear of control arm. Keep in position with heavy wire attached to crossmember. Remove bolt mounting stabilizer bar link to radius rod. Move link out of way. Separate radius rod from body.

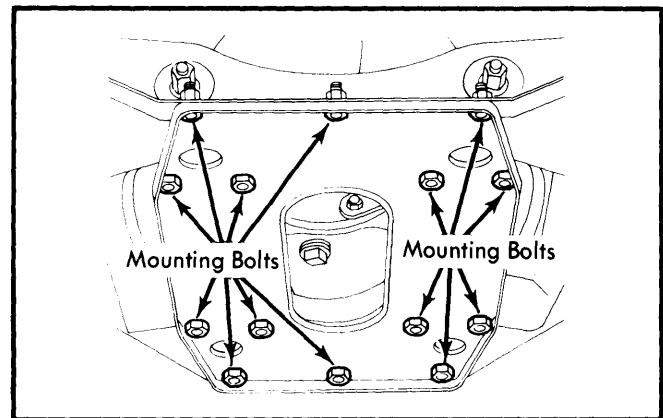

Fig. 4 Bolts and Setscrews Mounting Support Plate to Crossmember and Inner Fulcrum Brackets

4) Remove 14 bolts mounting support plate to crossmember and inner fulcrum brackets. Separate shock absorber at upper mount. Drift out pivot pin.

5) Separate inner fulcrum from control arm. Guide out control arm and radius rod.

Installation — 1) Smear bearing cage with grease and force bearing into lower control arm. Marking cast on bearing faces out. Insert bearing tube for other end and force in opposite end bearing. Repeat procedure for other boss.

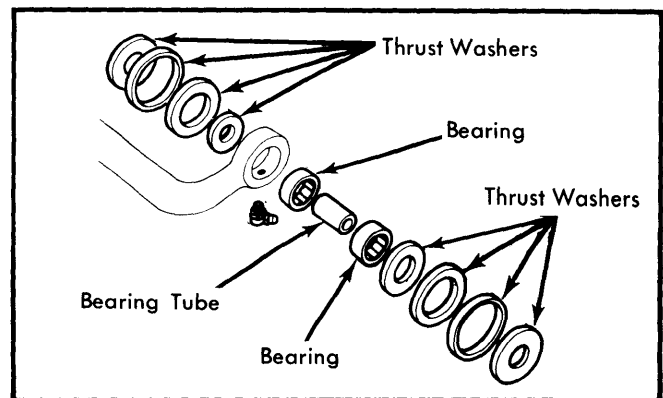

Fig. 5 Fulcrum Boss Assembly

2) Assemble radius rod to control arm. Lightly coat thrust washers, new oil seals and oil seal retainers with grease. Fit assemblies into place on control arm.

Rear Suspension

JAGUAR (Cont.)

3) Insert control arm to inner fulcrum mounting bracket. Make sure radius rod bracket faces toward front of suspension.

4) Insert dummy shaft from each end to keep bearings positioned then locate control arm in bracket. Slip in fulcrum shaft while pushing out dummy shaft. Install lock nut.

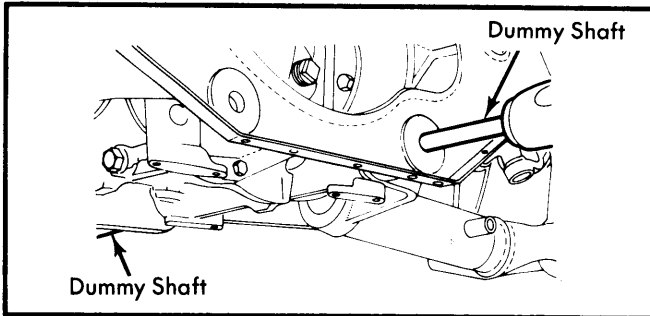

Fig. 6 Locating Control Arm in Mounting Bracket with Dummy Shafts

5) To install remaining components, reverse removal procedure.

STABILIZER BAR & LINKS

Removal, XJS — Raise vehicle and place on safety stands. Remove left rear wheel. Loosen exhaust pipe clamp nuts on right side forward of crossmember. Remove bolts mounting stabilizer bar to top of connecting links. Remove brackets mounting stabilizer bar to floorpan. Pull exhaust pipe apart. Maneuver stabilizer through left fender opening. Remove nuts and bolts mounting connecting link, then separate from radius rod.

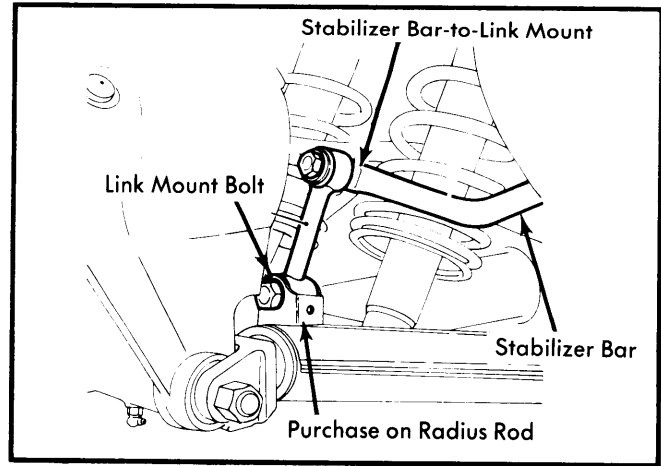

Fig. 7 Installed View of Stabilizer Bar and Connecting Link

Installation — To install stabilizer bar and connecting links, reverse removal procedure. Make sure exhaust system does not leak.

TIGHTENING SPECIFICATIONS

Application	Ft. Lbs. (mkg)
Radius Rod-to-Control Arm.....	60-70 (8.3-9.7)
Radius Rod-to-Body.....	40-45 (5.5-6.2)
Shock Absorbers.....	32-36 (4.4-5.0)
Support Plate-to-Crossmember and Inner Fulcrum Mounting.....	14-18 (1.9-2.5)
Inner Fulcrum Shaft.....	45-50 (6.2-6.9)
Stabilizer Bar Bracket-to-Body.....	14-18 (1.9-2.5)