

TOYOTA CELICA, COROLLA & CRESSIDA

Celica
Corolla
Cressida

REMOVAL & INSTALLATION

DESCRIPTION

Independent strut type suspension consisting of vertically mounted strut assemblies, lower control arms, strut rods and a stabilizer bar. Individual strut assembly is mounted at top to inner fender by a thrust bearing and at bottom to lower control arm by means of a ball joint. Strut assembly consists of a shock absorber built into strut outer tube, a coil spring mounted on outside of strut tube and a steering knuckle integral with bottom of strut tube. A strut rod is mounted between lower control arm and frame. A stabilizer bar is mounted to front frame members and connected at ends to lower control arms. The suspension crossmember that serves as support for all suspension components is removable.

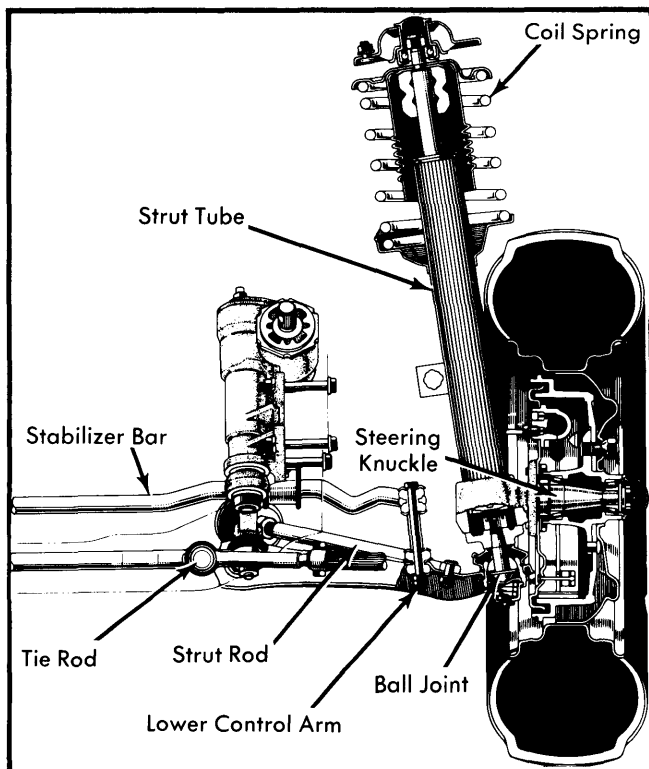

Fig. 1 Assembled View of Front Suspension Assembly (Corolla Shown; Celica & Cressida Similar)

ADJUSTMENT

WHEEL ALIGNMENT SPECIFICATIONS & PROCEDURES

See *Wheel Alignment Specifications & Procedures* in **WHEEL ALIGNMENT** Section.

WHEEL BEARING ADJUSTMENT

See *Wheel Bearing Adjustment* in **WHEEL ALIGNMENT** Section.

BALL JOINT CHECKING

See *Ball Joint Checking* in **WHEEL ALIGNMENT** Section.

STRUT ASSEMBLY

Removal – 1) Raise and support vehicle. Remove front wheel. Disconnect brake tube and flexible hose.

2) Remove 3 nuts retaining top of strut assembly to vehicle. Remove bolts holding lower end of strut tube to steering knuckle.

3) Pull down on control arm to gain clearance and remove strut assembly (with brake and hub assembly attached) from vehicle.

Disassembly – 1) Install assembly in vise, clamping portion of strut tube below flange.

2) Use suitable spring compressor to collapse spring enough to remove strut rod top nut. Relieve pressure on spring, remove spring and disassemble shock absorber top end retaining components.

3) Lift shock absorber piston rod from cylinder. On Corolla, lower end components may be disassembled. Fig. 2. On other models, piston valve assembly on lower end is integral with piston rod.

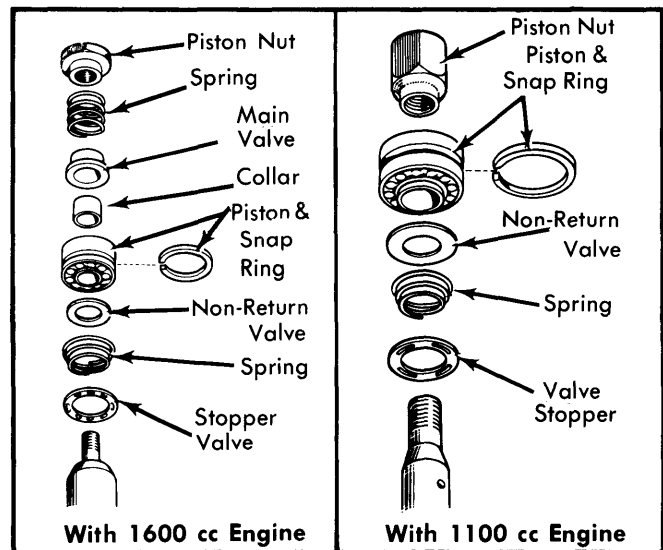

Fig. 2 Lower End Components of Piston Rod for Corolla Models

Reassembly – Thoroughly clean and inspect all components. Replace any damaged parts. Install shock absorber components into cylinder in reverse of disassembly procedure, noting the following:

- Follow appropriate illustration for reassembling Corolla piston rod components. Fig. 2.
- After installing piston nut, stake it in place.
- When installing base valve onto cylinder, use a soft-face hammer to drive into place.
- Add specified amount of new shock absorber oil to cylinder.
- Before fully tightening ring nut, pull piston rod out of cylinder about 3-4".

Front Suspension

TOYOTA CELICA, COROLLA & CRESSIDA (Cont.)

Shock Absorber Oil Amount

Application	Ounces (cc)
Celica	12.0 (325)
Corolla	
With 1100 cc Engine	9.5-9.8 (280-290)
With 1600 cc Engine	10.6 (315)
Cressida	10.8 (320)

Installation — To install strut assembly in vehicle, reverse removal procedure, noting the following:

- After top end of strut is attached to mounting, fill bearing recess, which protrudes into engine compartment, with multi-purpose grease.
- Always use new self-locking nut on top of piston rod.

CONTROL ARM

Removal — 1) Raise and support front of vehicle. Remove front wheel. Remove strut assembly-to-knuckle mounting bolts.

2) On Corolla and Cressida, detach tie rod end ball joint from steering arm. On Celica, detach ball joint from steering arm.

3) On all models, separate stabilizer bar and strut bar from control arm (stabilizer bar shield may have to be removed first on some models).

4) Remove control arm pivot bolt and remove control arm and ball joint assembly from vehicle.

Disassembly — 1) On Corolla and Cressida, place control arm assembly in vise and use suitable puller to remove steering arm from ball joint.

2) Pry dust cover from ball joint and discard (also discard dust cover snap ring or retaining wire).

3) Press bushing out of control arm toward front side of arm, using suitable press and arbor.

Reassembly — Use suitable support and press in new bushing. Position new ball joint dust cap and install new retaining wire or snap ring.

Installation — To install, reverse removal procedure.

STABILIZER BAR

Removal — Disconnect stabilizer bar from both control arms. Remove engine protective cover, if equipped. Remove bolts

securing mounting brackets to chassis and remove stabilizer bar.

Installation — To install, reverse removal procedure. Make sure components connecting stabilizer bar to control arms are installed properly.

STRUT ROD

Removal — Raise vehicle and place safety stands under vehicle. Remove nut from front of strut rod and remove washer, retainer, and rubber grommet. Remove bolts connecting strut rod to control arm and remove rod from vehicle.

Installation — On Corolla, install inside retaining nut so its inner edge is 3.43" (87.2 mm) from outer end of threaded portion of strut rod. On Celica, set distance between outer side of staked nut and inner mounting hole on other end of rod at 14.9" (379 mm); on Cressida, set this distance at 15.9" (405 mm). Place rod in vehicle and tighten mounting hardware.

SUSPENSION CROSSMEMBER

Removal — Disconnect control arms as previously outlined. Place a jack under engine for support and remove nuts securing motor mounts to crossmember. Remove protective cover from under engine. Remove bolts securing crossmember to body and remove crossmember.

Installation — To install, reverse removal procedure. Make sure components connecting stabilizer bar to control arms are installed in correct order.

TIGHTENING SPECIFICATIONS

Application	Ft. Lbs. (mkg)
Control Arm-to-Crossmember	
Celica, Corolla	51-65 (7.0-9.0)
Cressida	⓪65-94 (9.0-13.0)
Control Arm-to-Strut	
Celica, Corolla	29-40 (4.0-5.5)
Cressida	43-53 (6.0-7.4)
Control Arm-to-Stabilizer	11-15 (1.4-2.2)
Ball Joint-to-Knuckle Arm	51-65 (7.0-9.0)
Knuckle Arm-to-Strut Tube	
Corolla	51-65 (7.0-9.0)
Celica, Cressida	58-86 (8.0-12.0)
Piston Rod-to-Mounting Plate	29-40 (4.0-5.5)
Piston Rod Ring Nut	73-108 (10.0-15.0)
Lower Piston Nut (Corolla Only)	
KE Series	43-54 (6.0-7.5)
TE Series	14-22 (1.9-3.1)

⓪ — With vehicle at full curb weight.