

PORSCHE 911SC & TURBO

**911SC
Turbo**

DESCRIPTION

Independent strut type suspension with torsion bars. Strut assemblies are mounted to inner fender panels at top by thrust bearings. Bottom of strut assemblies are mounted to control arms by ball joints. Steering knuckle and shock absorbers are integral with individual strut assembly. Control arms pivot in mounts connected to body at front and in mounts integral with suspension crossmember at rear. Torsion bars anchor to control arm at front and to suspension crossmember at rear. Suspension crossmember also serves as mount for steering gear and is removable.

ADJUSTMENT

WHEEL ALIGNMENT SPECIFICATIONS & PROCEDURES

See *Wheel Alignment Specifications & Procedures* in **WHEEL ALIGNMENT** Section.

WHEEL BEARING ADJUSTMENT

See *Wheel Alignment Specifications & Procedures* in **WHEEL ALIGNMENT** Section.

BALL JOINT CHECKING

See *Ball Joint Checking* in **WHEEL ALIGNMENT** Section.

REMOVAL & INSTALLATION

STRUT ASSEMBLY AND THRUST BEARING

Removal — 1) Raise vehicle and place safety stands under body. Remove wheel and tire. Remove brake rotor and brake caliper.

NOTE — If necessary, refer to appropriate article in **BRAKE SYSTEMS** section.

2) Remove tie rod end strut nut and separate tie rod end from steering arm. Unscrew adjusting screw from torsion bar adjusting lever and remove lever. Remove ball joint retaining bolt at bottom of strut assembly and push control arm down to separate strut assembly from ball joint.

3) Remove center nut from upper strut assembly mount from inside luggage compartment. Remove lock washer, tab washer and strut assembly. Mark position of pressure plates on fender panel and remove Allen head bolts and pressure plates. Remove thrust, bearing and support.

NOTE — Thrust bearing can be removed without completely removing strut assembly by disconnecting upper mount and pulling down on control arm to separate from thrust bearing.

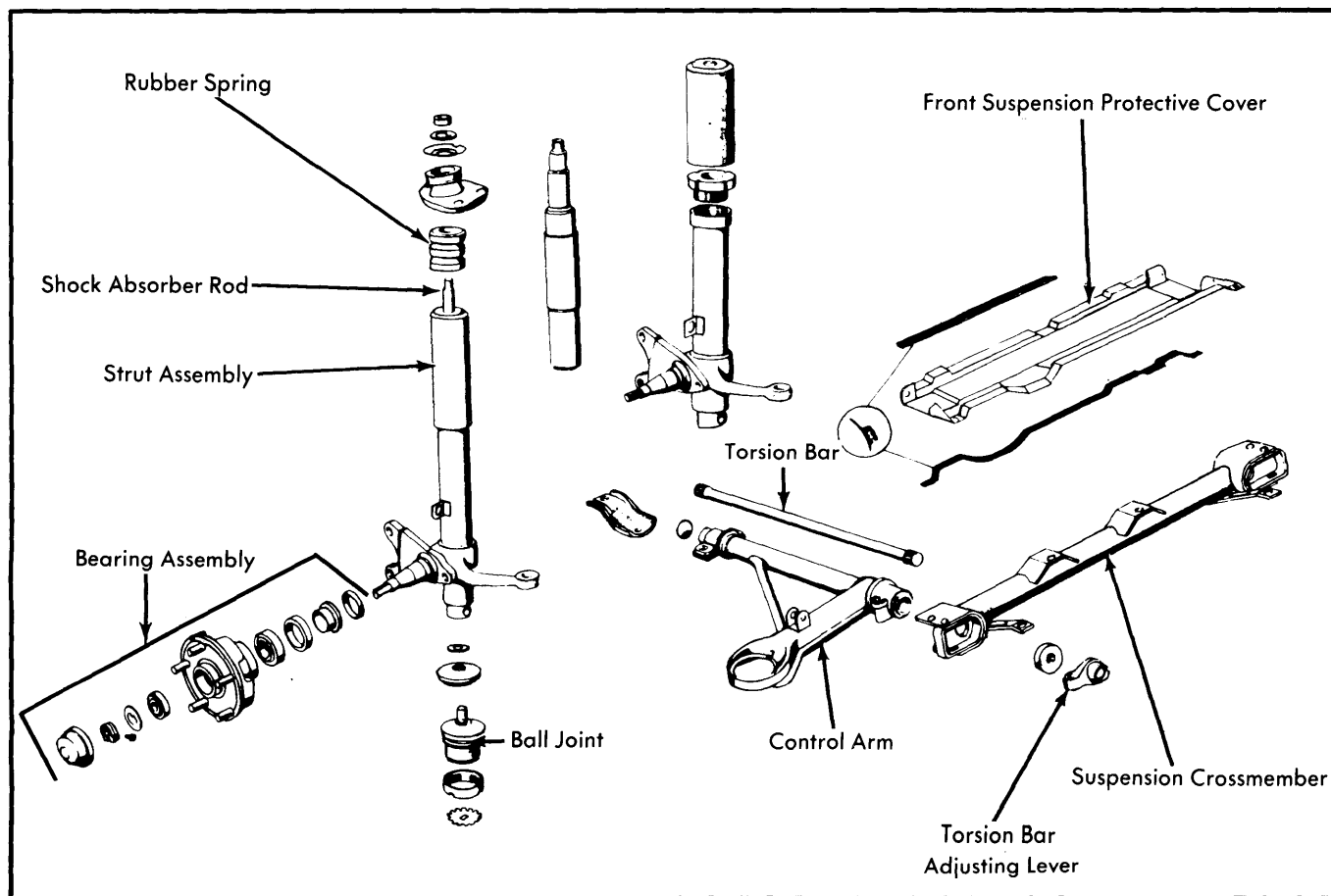

Fig. 1 Exploded View of Front Suspension Assembly

Front Suspension

PORSCHE 911SC & TURBO (Cont.)

Installation — 1) Install thrust bearing and support. Place pressure plates in proper position and tighten Allen head bolts. Inspect strut assembly for leaks, if leak is discovered, strut assembly must be replaced.

2) Push rod to bottom of stroke, if flange does not bottom out against strut tube, replace strut assembly. There should be no variation of pressure when pushing in or pulling out on rod.

3) Install strut assembly in proper position in vehicle. Install hollow rubber spring, new lock washer, and tighten nut. Fit strut assembly to ball joint and tighten nut.

NOTE — Make sure steel washer is between ball joint and stud.

4) Push control arm lever down to stop and install adjusting lever on torsion bar. Grease threads of adjusting screw with suitable grease and install screw. Make sure closing cover is correctly seated against adjusting lever.

5) Install tie rod and retighten nut. Install remaining components. See appropriate article in BRAKE SYSTEM Section. Tighten all nuts and bolts, bleed brake system, check wheel alignment and riding height.

CONTROL ARM & BALL JOINT

Removal — 1) Raise vehicle and place safety stands under body. Remove wheel and tire. Remove adjusting screw from torsion bar lever and remove lever. Disconnect strut assembly from control arm as previously outlined. Remove rear control arm mounting bolt at suspension crossmember. Remove two bolts securing front control arm mount to body. Slide control arm with torsion bar out of suspension crossmember.

CAUTION — If both control arms are being removed, reinstall rear control arm mounting bolt in suspension crossmember before removing opposite side.

2) Secure control arm in a vise and remove ball joint retaining nut using a suitable wrench. Remove ball joint from control arm. Control arm should pivot smoothly in mounts. If control arm binds or is distorted, it must be replaced.

3) Inspect torsion bars for damaged serrations. Check sealing bellows on ball joint, replace if damaged or cracked. Remove sealing bellows with a flat chisel and install using suitable mandrel to press bellows on with.

Installation — 1) Install ball joint in control arm and tighten grooved nut. Secure nut by bending over tab on lock washer. Grease entire torsion bar and install in control arm. Place control arm in proper position in vehicle and tighten mounting bolts (front to rear).

2) Install strut assembly on ball joint and tighten retaining bolt. Push down on control arm until it contacts stops and install torsion bar seal and adjusting lever. Slide adjusting lever against torsion bar until it reaches stop. Grease adjusting bolt threads and install in lever. Make sure closing cover is correctly seated against adjusting lever. Install control arm protective cover. Install wheel and tire, lower vehicle and check riding height and wheel alignment.

SUSPENSION CROSSMEMBER

Removal — Raise vehicle and place safety stands under vehicle. Remove front axle protective cover. Remove steering gear bolts from crossmember. Remove rear control arm mounting bolts as previously outlined and remove suspension crossmember. Place crossmember on level surface and check for distortion. Inspect for cracks or damage.

Installation — Place crossmember in proper position in vehicle and install control arm mounting bolts as previously outlined. Install steering gear bolts and tighten. Install front suspension protective cover. Lower vehicle and check riding height and wheel alignment.

FRONT AXLE STABILIZER

Removal — Remove stabilizer shackles. Unbolt stabilizer lever retaining nuts and extract lever. Remove stabilizer mounting cover hardware and gently pry cover from vehicle.

Installation — Check all rubber grommets for signs of wear and replace components as necessary. Coat rubber parts with suitable lubricant. Reinstall stabilizer mounting cover, center stabilizer, then tighten attaching bolts. Seat stabilizer lever in position so stabilizer protrudes approximately .118" (3 mm) beyond lever. Tighten retaining nuts and install shackles.

FRONT AXLE ASSEMBLY

Removal — Disconnect brake hose and plug opening. Disconnect stabilizer bar at crossmember. Remove tie rod shield. Remove bolts at carrier and control arm brackets. Place jack under crossmember. Disconnect steering shaft. Remove upper strut mounting hardware. Carefully pull front axle assembly from vehicle.

Installation — To install, reverse removal procedure.

TIGHTENING SPECIFICATIONS	
Application	Ft. Lbs. (mkg)
Strut Assembly-to-Ball Joint Securing Bolt	47 (6.5)
Strut Assembly Thrust Bearing	58 (8.0)
Pressure Plate Allen Head Bolts	34 (4.7)
Front Control Arm Mount	34 (4.7)
Control Arm & Suspension Crossmember Mounting Bolt	65 (9.0)
Steering Gear Bolts	34 (4.7)
Ball Joint-to-Control Arm Grooved Nut	108 (14.9)
Front Protective Clamp Allen Head Bolt	32 (4.4)
Suspension Protective Cover-to-Body Bolts	34 (4.7)
Suspension Protective Cover-to-Crossmember Bolts	11 (1.5)
Tie Rod End Strut Nut	32 (4.4)