

Front Suspension

FIAT 131

131

DESCRIPTION

Strut type front suspension consisting of a vertically mounted strut assembly. Strut assembly is mounted to body at the top by means of a thrust bearing and lower end of strut is connected to steering knuckle. Strut assembly consists of hydraulic shock absorber with a coil spring mounted over outside. Lower control arm is connected to steering knuckle through ball joint and to front crossmember. A stabilizer bar is mounted to lower control arm and to frame.

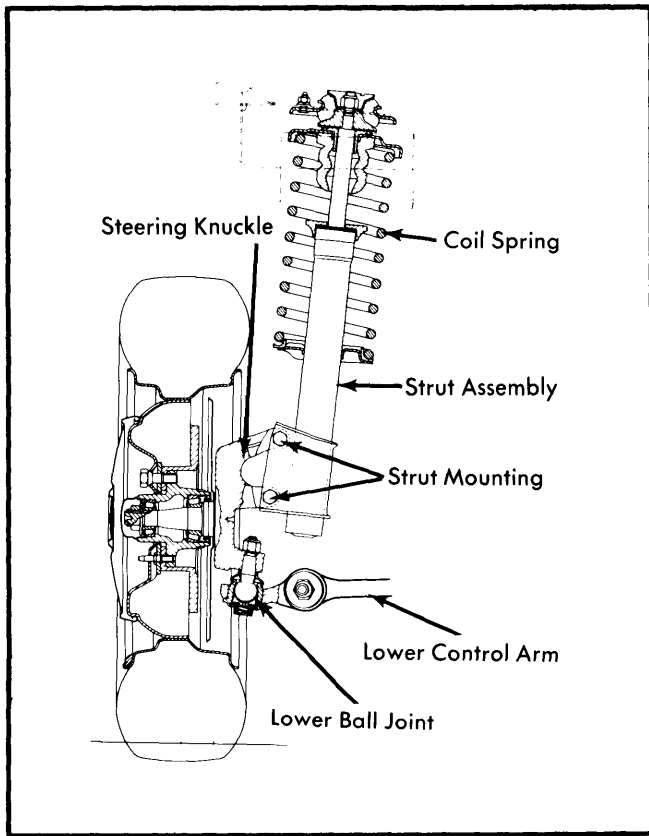

Fig. 1 Fiat 131 Front Suspension Assembly

ADJUSTMENTS

WHEEL ALIGNMENT SPECIFICATIONS & PROCEDURES

See *Wheel Alignment Specifications and Procedures* in *WHEEL ALIGNMENT* Section.

WHEEL BEARING ADJUSTMENT

See *Wheel Bearing Adjustment* in *WHEEL ALIGNMENT* Section.

BALL JOINT CHECKING

See *Ball Joint Checking* in *WHEEL ALIGNMENT* Section.

REMOVAL & INSTALLATION

FRONT SUSPENSION ASSEMBLY

Removal – Raise vehicle, support with safety stands, and remove wheel and tire. Disconnect brake hose from tube at clip mounted in fender well. Disconnect tie rod from steering knuckle. Disconnect stabilizer bar from lower control arm. Remove control arm-to-crossmember attaching bolt and separate control arm from crossmember. Position a jack under suspension assembly, then remove nuts and washers attaching top of strut assembly to body. Carefully lower suspension assembly from vehicle. Individual components may be removed from suspension assembly as follows: Disconnect control arm by removing ball joint stud nut and separating ball joint and lower control arm from steering knuckle. Remove shock absorber assembly by removing nuts and bolts attaching assembly to steering knuckle. Remove coil spring by using a coil spring compressor to compress the spring and removing spring retainer attaching nut.

Installation – Install suspension assembly in vehicle and secure strut assembly to body. Install control arm to stabilizer bar, and then to crossmember. Install attaching nuts and bolts loosely. Install tie rod to steering knuckle, and connect brake hose to tube. Install wheel and tire. Lower vehicle and tighten nuts and bolts to specifications with weight of vehicle on ground. Check wheel alignment.

CROSSMEMBER

Removal – Remove (4) bolts mounting steering box to crossmember. Remove engine mount bolts and suitably support engine. Disconnect lower control arms from crossmember. Remove (4) crossmember to frame bolts and remove crossmember.

Installation – To install, reverse removal procedure.

STRUT ASSEMBLY

Removal – 1) Remove (3) nuts mounting strut assembly to inner fender panel. Raise vehicle and place on safety stands. Remove wheel. Remove nuts and bolts mounting strut to steering knuckle. Remove strut complete with coil spring.

2) To remove coil spring from strut, proceed as follows: Use a spring compressor (A74277) and collapse coil until tension is relieved. Remove retainer mounting nut from top end of strut. Release spring compressor and remove coil.

Installation – To install, reverse removal procedure.

TIGHTENING SPECIFICATIONS

Application	Ft. Lbs.(mkg)
Ball Joint-to-Steering Knuckle	58(8)
Control Arm-to-Crossmember	65(9)
Strut Assembly-to-Knuckle	36(5)
Strut Assembly-to-Upper Mount	43(6)
Strut Upper Mount-to-Body	18(2.5)
Stabilizer Bar-to-Crossmember	65(9)
Stabilizer Bar-to-Control Arm	43(6)