

FIAT 128

128
Sedan
Station Wagon
3P

DESCRIPTION

Suspension is independent, strut type. Consists of double-action shock absorbers with surrounding coil springs. Strut assemblies are mounted to inner fender panel at top and to steering knuckle at bottom. Steering knuckle is also bearing carrier for drive axles. Lower control arm is connected to knuckle by ball joint. Stabilizer bar is also incorporated.

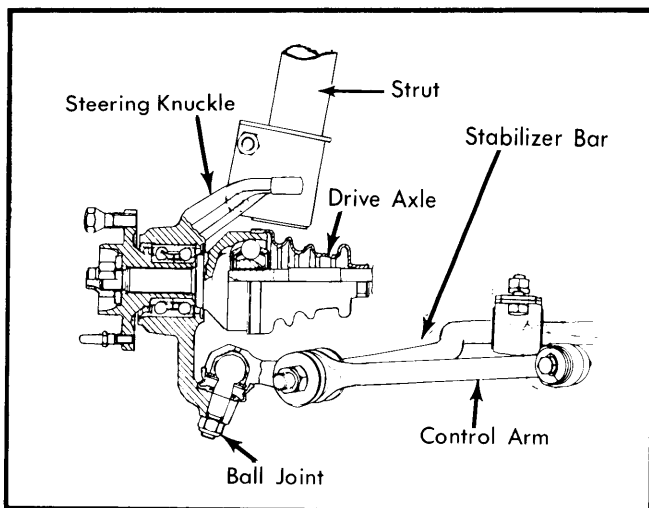

Fig. 1 Assembled View of Fiat 128 Front Suspension

ADJUSTMENTS

WHEEL ALIGNMENT SPECIFICATIONS & PROCEDURES

See *Wheel Alignment Specifications and Procedures* in **WHEEL ALIGNMENT** section.

WHEEL BEARING ADJUSTMENT

See *Wheel Bearing Adjustment* in **WHEEL ALIGNMENT** section.

BALL JOINT CHECKING

See *Ball Joint Checking* in **WHEEL ALIGNMENT** section.

REMOVAL & INSTALLATION

COMPLETE SUSPENSION ASSEMBLY

NOTE — This procedure is for complete suspension assembly on one side only.

Removal — 1) Raise and support front of vehicle. Remove brake caliper, without detaching brake hose, and suspend out of way (be sure there is no strain on hose or line).

2) Remove nut from tie rod end stud and separate tie rod end from steering knuckle. Remove nut from stabilizer bar at control arm. Note any shims at this connection.

3) Remove control arm pivot bolt from chassis mount. Detach upper strut assembly mount from fender panel. Remove axle nut from hub. Pull out on suspension assembly to separate axle from hub. Remove suspension assembly and secure axle to prevent pulling out of differential.

Installation — To install, reverse removal procedure, tightening axle nut before lowering vehicle and tightening all other nuts and bolts with vehicle resting on ground. Be sure stabilizer shims are in proper position.

STRUT ASSEMBLY

Removal — Raise and support front of vehicle. Detach upper strut mount from fender panel. Remove bolts holding strut to steering knuckle. Pull knuckle down to separate and remove strut assembly.

Disassembly and Reassembly — Install suitable spring compressor and compress spring enough to remove upper strut nut. Slowly release spring and remove upper mount and spring. To reassemble, reverse disassembly procedure.

NOTE — If replacing coil springs, be sure same color-coded class of spring is installed (different colors show different weights).

Installation — To install, reverse removal procedure, tightening nuts to specifications. Be sure lower mount nuts are tightened after vehicle is at curb weight.

CONTROL ARM, BUSHINGS & BALL JOINTS

Removal — Remove complete suspension assembly as outlined. Remove ball joint stud nut and separate from steering knuckle.

Disassembly — To replace control arm bushings, drill out metal sleeve from inside rubber bushings and remove bushings. If ball joint is defective, replace entire control arm assembly.

Reassembly — Place outer washer, bushing and sleeve on centering pin of suitable bushing installation tool (A.74221). Place control arm over bushing. Position inner bushing and washer on control arm. Place this assembly in a vise and press into place. Sleeve will bellow out over washers, securing bushings in control arm.

Installation — To install, reverse removal procedure.

TIGHTENING SPECIFICATIONS

Application	Ft. Lbs. (mkg)
Front Axle-to-Hub Nut	
Exc. 3P	101 (14.0)
3P	112 (15.5)
Control Arm Pivot Bolt	
Exc. 3P	18 (2.5)
3P	32 (4.5)
Stabilizer Bar-to-Control Arm	43 (6.0)
Stabilizer Bar-to-Chassis	22 (3.0)
Strut-to-Control Arm (3P)	51 (7.0)
Ball Joint Nut	58 (8.0)
Strut Assembly Mount	
Upper	18 (2.5)
Lower	43 (6.0)