

## DATSUN PICKUP

### Pickup

### DESCRIPTION

Front suspension is an independent type with upper and lower control arms which are connected by ball joints. This suspension also incorporates a torsion bar which connects to lower control arm inner end and to frame bracket, a strut rod which connects to lower control arm outer end and an optional stabilizer bar. A double-acting shock absorber is also used. See Fig. 1.

### ADJUSTMENT

### WHEEL ALIGNMENT SPECIFICATIONS & PROCEDURES

See *Wheel Alignment Specifications & Procedures* in *WHEEL ALIGNMENT* Section.

### WHEEL BEARING ADJUSTMENT

See *Wheel Bearing Adjustment* in *WHEEL ALIGNMENT* Section.

### BALL JOINT CHECKING

See *Ball Joint Checking* in *WHEEL ALIGNMENT* Section.

### REMOVAL & INSTALLATION

### SHOCK ABSORBER

**Removal** - 1) Raise and support front of vehicle. Remove wheel assembly.

2) While holding upper stem of shock absorber, remove lock nut, adjusting nut, washer and bushing from upper end of shock. Remove nut and bolt at lower end and remove shock absorber.

**Installation** - To install, reverse removal procedure and tighten nuts and bolts to specifications.

### TORSION BAR

**Removal** - 1) Raise and support front of vehicle. If removing left torsion bar, remove catalytic converter first.

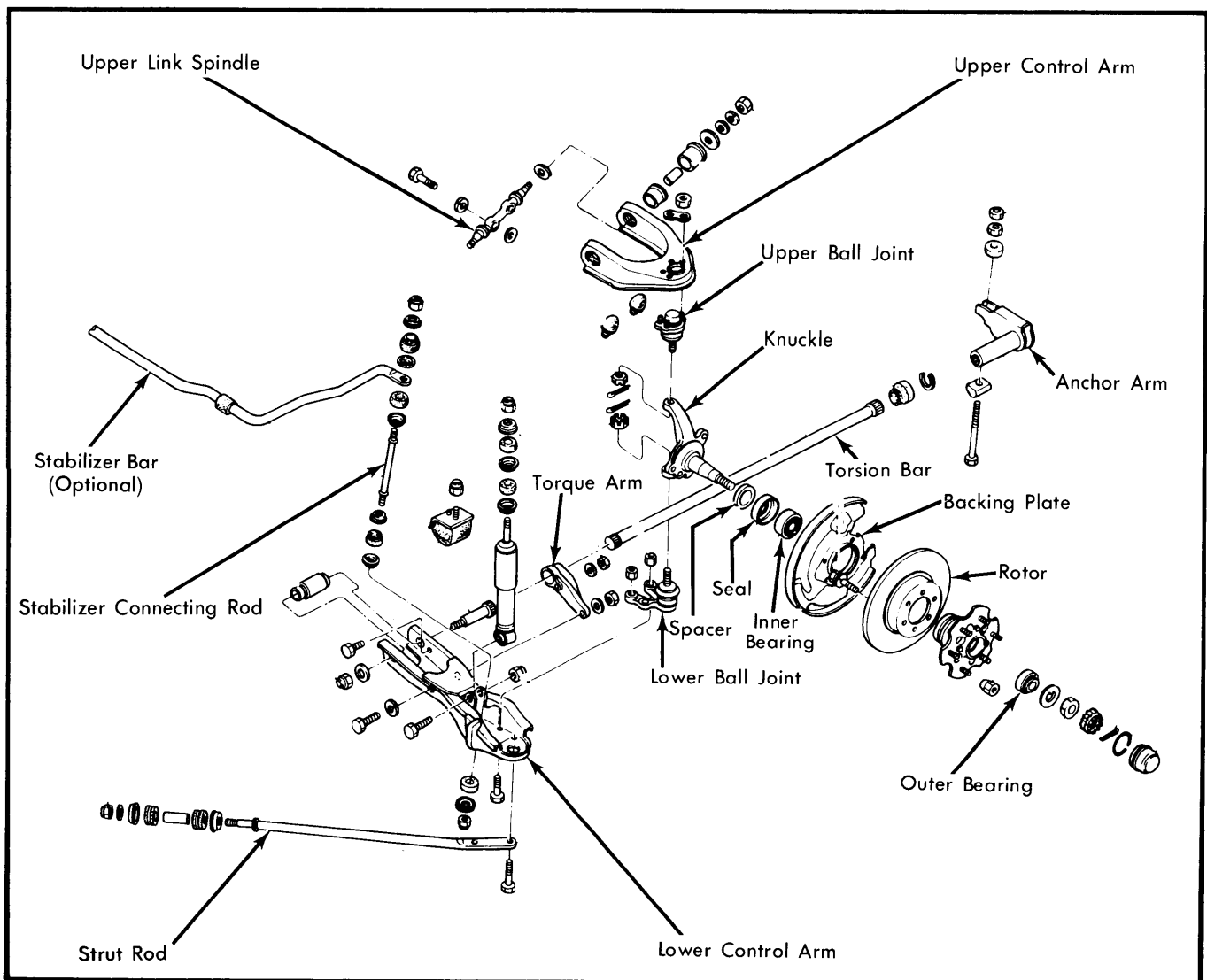

Fig. 1 Exploded View of Datsun Pickup Front Suspension

# Front Suspension

## DATSUN PICKUP (Cont.)

2) Loosen nuts at anchor arm bolt. Remove dust cover at back end of torsion bar and detach snap ring. Pull anchor arm rearward and withdraw torsion bar.

**Installation** - 1) Coat serrated portions of torsion bar with grease and position bar into torque arm.

**NOTE** - Torsion bars are identified for left and right installations with an "R" and "L" on end of bar.

2) Install anchor arm and tighten adjusting nut to obtain specified dimension for "A" when bar is in contact with rebound bumper. See Fig. 2.

3) Install snap ring and dust cover. Temporarily tighten adjusting nut until dimension "B" is obtained.

4) Install wheel assembly and lower vehicle. Be sure vehicle is at curb weight (full fuel tank and no passengers). Tighten anchor arm bolt lock nut to specification.

### Dimensions for Setting Torsion Bar

Application	In. (mm)
Dimension "A" .....	.28-.67 (7-17)
Dimension "B" .....	2.36-2.76 (60-70)

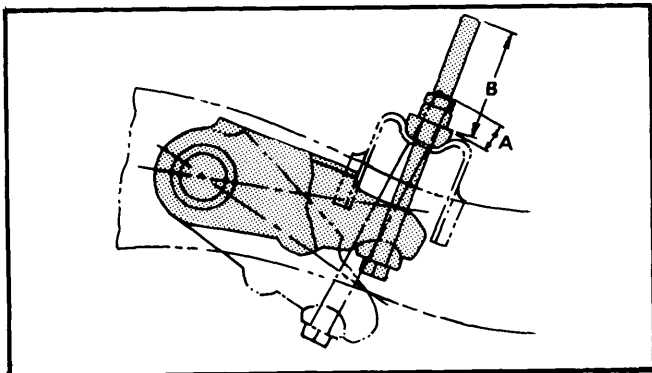

Fig. 2 View Showing Measuring Points for Installation of Anchor Pin

### UPPER CONTROL ARM & BALL JOINT

**Removal** - 1) Raise and support front of vehicle. Remove wheel assembly. Loosen torsion bar anchor arm lock nut and adjusting nut.

2) Remove cotter pin and nut from upper ball joint and separate ball joint from steering knuckle with suitable tool.

3) Loosen bolts holding upper ball joint to upper control arm and remove ball joint.

4) Remove bolts retaining upper link spindle and remove spindle and upper control arm from mounting, collecting all camber adjusting shims present.

5) Remove nuts and washers at both ends of upper link spindle. Place assembly on a vise and press upper link spindle from one end and remove rubber bushing. Press from other end and remove other bushing. Remove spindle from upper control arm.

**Installation** - 1) Apply soapy solution or other lubricant to rubber bushing and press into place from outer side of control arm until bushing protrudes as specified for dimension "C". See Fig. 3.

2) Position upper link spindle into control arm, with spindle washer having its beveled edge inward as shown.

3) Press-fit bushing on other end of spindle and control arm as described in step 1) above.

4) After bushings are installed, check dimensions "C" "D" and "E" to be sure they match given specifications.

### Dimensions for Installing Upper Control Arm Bushings

Application	In. (mm)
Dimension "C" .....	.18 (4.5)
Dimension "D" .....	5.7-5.8 (144.6-146.6)
Dimension "E" .....	1.1 (28.3)

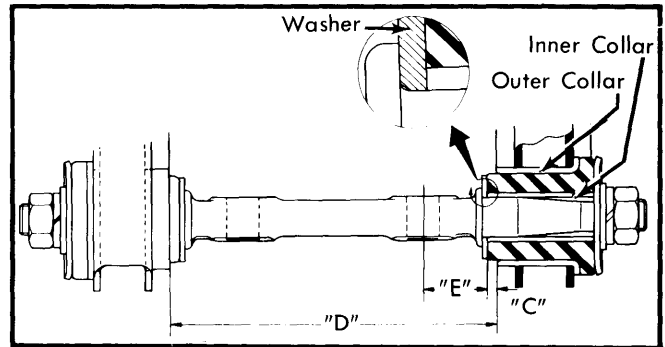

Fig. 3 Showing Installed Positions of Bushings for Upper Control Arm

5) Install upper control arm assembly to its mounting by setting upper link spindle-to-control arm position as shown. See Fig. 4. Tighten mounting bolts to specifications, installing camber shims to original positions.

6) Install upper ball joint to upper control arm, tightening mounting nuts to specifications.

7) Position upper ball joint stud into steering knuckle hole and install retaining nut and cotter pin. Be sure grease does not contact tapered area of ball joint stud and knuckle or ball joint stud threads.

8) Install tire and wheel. Adjust vehicle riding height. See "Riding Height" under appropriate article in WHEEL ALIGNMENT section. Check and adjust wheel alignment.

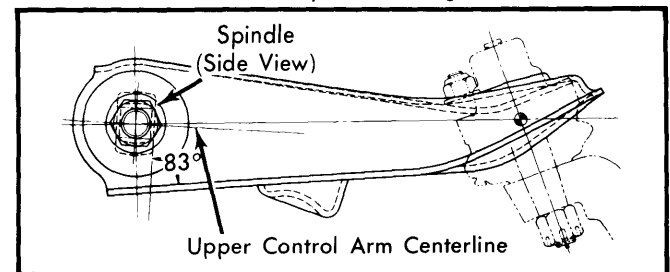

Fig. 4 Side View of Upper Control Arm Showing Alignment of Spindle in Relation to Control Arm Centerline

## DATSUN PICKUP (Cont.)

### LOWER CONTROL ARM & BALL JOINT

**Removal** — 1) Raise and support front of vehicle. Remove wheel assembly. Remove shock absorber as described in this article.

2) Loosen torsion bar anchor arm lock nut and adjusting nut and remove anchor arm bolt. Remove dust cover and snap ring and move anchor arm and torsion bar rearward as far as possible.

3) Detach stabilizer connecting rod from lower control arm. Remove strut rod from lower control arm. Remove cotter pin and nut and remove lower ball joint from knuckle.

4) Remove lower control arm spindle by tapping on front end of spindle and driving toward rear. Move torsion bar down as required. Remove spindle.

5) Remove lower ball joint by removing retaining nuts and bolts. Using suitable drift (ST36070000), drive out lower control arm bushings. Fig. 5. Remove bolt attaching torque arm to lower control arm and remove torque arm.

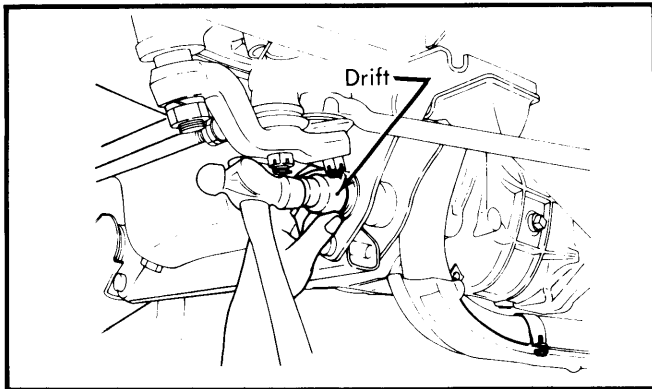

**Fig. 5 Removing Bushings from Lower Control Arm**

**Installation** — To install, reverse removal procedure, tightening nuts and bolts to specifications. Be sure grease does not contact tapered area of ball joint stud or knuckle hole and does not contact ball joint threads. Adjust vehicle riding height. See appropriate article in *WHEEL ALIGNMENT* section.

### STRUT ROD

**Removal** — Remove bolt holding strut rod to lower control arm and separate these parts. Remove nut attaching strut rod to bracket and remove rod with bushings, collar and washers.

**Installation** — To install, reverse removal procedure, noting the following: Swing strut rod a few times to settle bushings and washers; do not allow grease or oil to contact rubber bushings; tighten retaining nuts and bolts to specifications.

### STABILIZER BAR

**Removal** — Remove nut holding stabilizer connecting rod to lower control arm. Remove bolt holding stabilizer mounting bracket to frame. Remove nut attaching stabilizer and connecting rod and remove these parts.

**Installation** — To install, reverse removal procedure, noting the following: Install stabilizer so white paint mark is on left side and be sure locating mark is positioned inside frame mount bushing.

### TIGHTENING SPECIFICATIONS

Application	Ft. Lbs. (mkg)
Shock Absorber Upper Nut .....	12-16 (1.7-2.2)
Shock Absorber Lower Nut .....	22-30 (3.1-4.1)
Anchor Bolt Lock Nut .....	22-30 (3.1-4.1)
Upper Control Arm Spindle Nut .....	56-76 (7.7-10.5)
Upper Link Spindle-to-Frame .....	80-108 (11.1-15.0)
Upper Ball Joint-to-Control Arm .....	12-16 (1.7-2.2)
Upper Ball Joint-to-Knuckle .....	58-72 (8-10)
Lower Ball Joint-to-Control Arm .....	28-38 (3.9-5.3)
Torque Arm-to-Lower Control Arm	
Outer Nut .....	20-27 (2.7-3.7)
Inner Nut .....	26-33 (3.6-4.6)
Lower Control Arm Spindle Nut .....	80-108 (11.1-15.0)
Lower Ball Joint-to-Knuckle .....	127-141 (17.5-19.5)
Strut Rod-to-Lower Control Arm .....	28-38 (3.9-5.3)
Strut Rod-to-Bracket .....	22-30 (3.0-4.2)