

Wheel Bearing Adjustment

TRIUMPH

adjustment is correct, a force of 2.2-3.1 lbs. (1.0-1.4 kg) will be required to rotate wheel.

NOTE — A force of 1.9-3.2 lbs. (.85-1.45 kg) is required to rotate wheel when measured at axle nut.

TOYOTA

Land Cruiser — Rotate drum and tighten adjustment nut to 43 ft. lbs (6 mkg). This will seat bearings. Loosen adjustment nut about $\frac{1}{8}$ turn. If brake drum rotates properly, install lock washer and tighten lock nut.

Pickup — Tighten front axle castle nut to 36 ft. lbs. to seat bearings, then back off until nut is finger tight. Retighten nut to 36 ft. lbs. and back off $\frac{1}{6}$ - $\frac{1}{3}$ turn and install cotter key. When properly adjusted, bearing preload should be as shown in table, when checked with pull scale attached to hub bolt.

All Other Models — Tighten castle nut bearing retainer nut 18.8-23.2 ft. lbs. and turn brake drum back and forth to seat bearing. Loosen nut until can be turned with fingers. Tighten nut to finger tight using a socket without the handle. If not aligned for cotter key installation, tighten until installation possible. Preload at hub (hub rotating) should be within specifications.

Bearing Preload Specifications

Application	Preload Lbs. (kg)
Corona77-1.9 (.35-.86)
Pickup66-1.98 (.30-.90)
Corolla, Celica66-1.5 (.30-.68)
Cressida	2.3-3.5 (1.0-1.6)

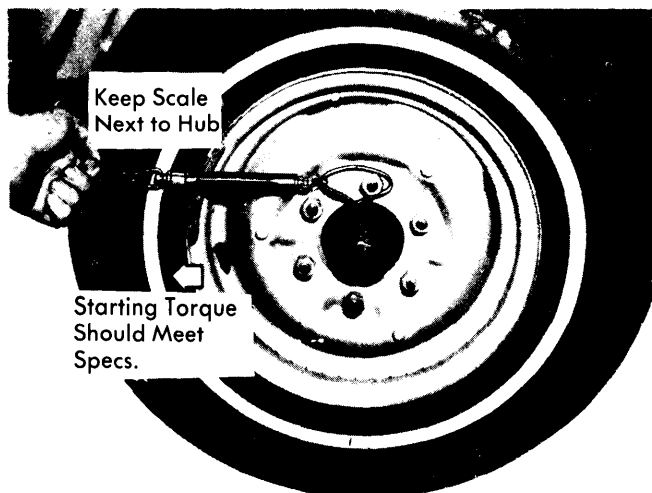

Fig. 1 Using a Pull Scale to Measure Wheel Bearing Starting Torque

TR7 — Raise and support front of vehicle, then remove wheel and tire. Check hub for excessive end play. If adjustment is necessary, remove grease cap and cotter key. Tighten spindle nut to 5 ft. lbs. (.7 mkg), then back nut off one flat and install cotter key.

All Others — Raise and support front of vehicle, then remove wheel and brake caliper. Attach a dial indicator and measure wheel bearing end play. If end play exceeds .003-.005" (.08-.13 mm), remove cotter key and loosen or tighten spindle nut until end play is within specifications. Install new cotter key.

NOTE — Do not exceed 5 ft. lbs. (.7 mkg) when torquing spindle nut.

VOLKSWAGEN

Type 1 (Front) — Torque adjusting nut to 7 ft. lbs. (1.0 mkg) while hand turning drum. Measure bearing play using a dial indicator. Hand tighten adjustment nut until bearing play is about .001-.005" (.03-.12 mm). Tighten retainer clamp.

Type 2 (Front) — Adjust clamp nut while rotating wheel. Adjustment is completed when thrust washer can be moved with a screwdriver and finger pressure.

All Others (Front) — Front wheel bearings are pressed into bearing housing and no adjustment is required. Tighten front axle nut on Dasher to 145 ft. lbs. (20 mkg) for M 18x1.5 nuts or 175 ft. lbs. (24 mkg) for M 20x1.5 nuts. For Rabbit and Scirocco models tighten nuts to 175 ft. lbs. (24 mkg).

Dasher, Rabbit & Scirocco (Rear) — Wheel bearings are correctly adjusted if thrust washer can be moved slightly with a screwdriver. **NOTE** — This will provide axial play of approximately .001-.003".

VOLVO

All Models — While rotating hub, torque nut to 50 ft. lbs. Loosen nut $\frac{1}{3}$ turn and check for hub rotating freely with no end play. If necessary to align cotter key holes loosen nut and install cotter key.

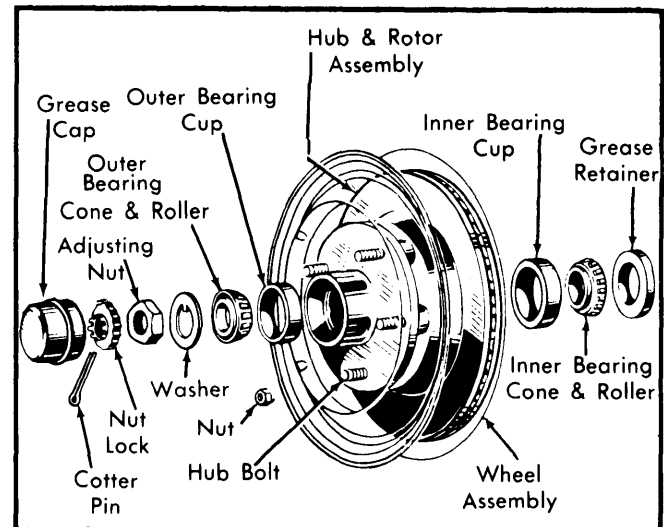

Fig. 2 Exploded View of Wheel Bearing Components with Disc Brakes