

VOLVO

240 Series
260 Series

DESCRIPTION

Volvo models may be equipped with either Girling disc brake calipers on all 4 wheels or with Girling calipers on front wheels and ATE calipers on rear wheels. Brake system incorporates 2 separate circuits: Hydraulic disc brake and mechanical parking brake. Service brakes are operated by a tandem master cylinder attached to a vacuum operated power assist unit. Master cylinder feeds hydraulic pressure to each circuit. One circuit feeds lower front caliper pistons and right rear caliper. Other circuit feeds upper front caliper pistons and left rear caliper. Additionally, valves are installed in both circuits to equally distribute braking power. A warning light, mounted on instrument panel, indicates pressure differences between circuits.

ADJUSTMENT

DISC BRAKES

Disc brakes are self-adjusting; therefore, no adjustment in service is required.

PARKING BRAKE

1) Remove center console rear ash tray, then working through ash tray hole, loosen parking brake cables adjusting screw until cables are slack. Raise and support rear of vehicle, then remove wheels. Align hole in parking brake drum with starwheel adjuster.

2) Tighten starwheel until drum can just be rotated by hand, then back off adjuster until drum just rotates freely. Install rear wheels. Tighten parking brake cable adjusting screw until parking brake is fully applied when lever is pulled three or four notches. Install ash tray and lower vehicle.

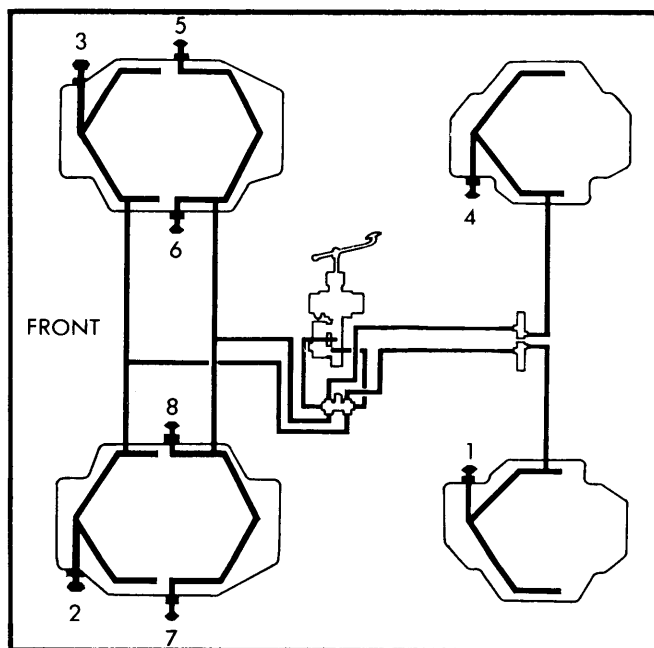

Fig. 1 Schematic of Bleeding Sequence

HYDRAULIC SYSTEM BLEEDING

NOTE — To ensure the best possible results, bleed brakes in proper sequence.

1) Start at left front brake. Connect bleed tubes to all three bleeder screws and immerse opposite end of tubes in a container partially filled with brake fluid. Pump brake pedal ten times, then keep pedal depressed and using assistants, open all three bleeder screws simultaneously. When pedal reaches end of travel, close all bleeder screws. Continue operation until all air is bled from caliper assembly. Repeat procedure on right front brake.

2) Depress brake pedal several times to level out master cylinder. Connect a bleed tube to right rear brake bleeder screw and immerse opposite end of tube in a container partially filled with brake fluid. Open bleeder screw and gravity bleed (no pumping of pedal) caliper assembly. Close bleeder screw when brake fluid is free of air bubbles. Repeat procedure on left rear brake.

REMOVAL & INSTALLATION

DISC PADS

Removal (All Types) — Raise and support vehicle. Remove wheel. Remove spring locks. Pull out one lock pin and hold damper springs in place. Remove springs and other lock pin. Use tool 2917 (or equivalent) and pull disc pads from caliper. If pads are to be reinstalled, index mark.

Installation, All; Front — Using tool 280 (or equivalent), seat pistons in caliper bore. **NOTE** — Use of screwdriver is discouraged because pads, seals or piston can be easily damaged. Insert pads and fit guide or lock pins, spring locks and tension springs.

Installation, Rear; ATE — Press pistons into caliper until bottomed in bore. Before installing disc pads, ensure pistons are in proper position to prevent brake squeal; piston recess should incline 20° in relation to lower guide area on caliper (See Fig. 2). Check piston angle using template SVO 2919 (or equivalent) and correct if necessary. Install disc pads and one guide pin. Install damper spring and remaining guide pin and secure with locking clips. After installation, depress brake pedal several times to position pads against rotor.

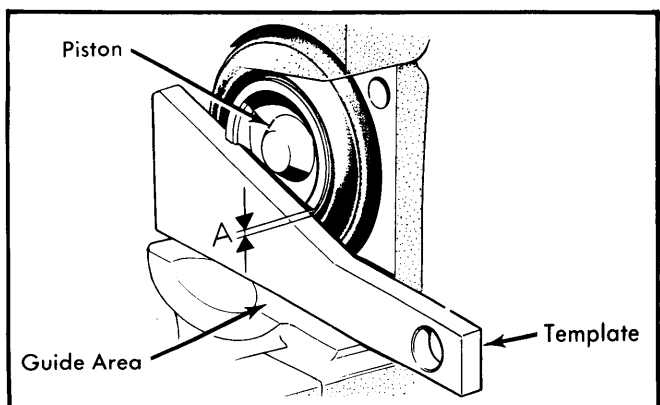

Fig. 2 Checking Piston Angle on Rear Brakes

VOLVO (Cont.)

Installation, Rear; Girling — Select new disc pads and fit to caliper. If caliper is equipped with intermediate plates between pad and caliper, reinstall plates. If round damper washers are used, reinstall with smaller contact face toward pad. **NOTE** — *DO NOT install intermediate plates in caliper with round damper washers.* Fit one lock pin and install damper spring, then insert last lock pin. Check free movement of pads.

CALIPER ASSEMBLY

Removal — Raise and support vehicle, and remove wheel. Disconnect brake line connections at caliper, and cap lines to prevent entry of foreign matter. Remove caliper mounting bolts and lift caliper from vehicle.

Installation — Position caliper assembly on mounting bracket, and install attaching bolts. After installing bolts, check clearance between disc pads and rotor on both sides of rotor; maximum deviation between sides should not exceed .022" (.01 mm). If clearance is not within specifications, correct by adding shims to caliper. Connect hydraulic lines to caliper and bleed brakes.

DISC BRAKE ROTOR

Removal — Raise and support vehicle, remove wheel. Remove caliper assembly as previously outlined. Unscrew rotor lock bolts. Pull rotor from wheel hub.

Inspection — Before removing rotor, mount a dial indicator and check rotor runout. Runout must not exceed .004" (.1 mm). Measure rotor thickness through one revolution, thickness must not vary more than .001" (.03 mm).

Installation — To install, reverse removal procedure.

PARKING BRAKE SHOES

Removal — Remove center console rear ash tray and loosen parking brake cable adjusting nut until cables are slack. Raise and support rear of vehicle and remove wheels. Remove caliper (without disconnecting hydraulic line) and support out of way, then remove rotor. Remove brake shoe return springs and lift off shoes and adjuster.

Installation — Reverse removal procedure and note the following: Replace brake drum (rotor) if out-of-round more than .008" (.2 mm). Apply a thin coat of heat resistant graphite grease to brake shoe sliding surfaces and to adjusting starwheel. After installation, adjust parking brake. See *Parking Brake*.

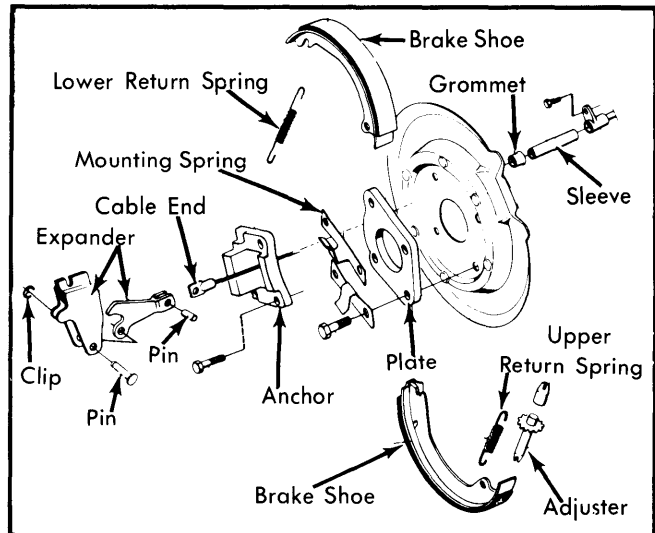

Fig. 3 Exploded View of Parking Brake Assembly

MASTER CYLINDER

Removal & Installation — Disconnect hydraulic lines at master cylinder and cap openings to prevent entry of foreign matter. Remove cylinder attaching hardware, and remove cylinder assembly from vehicle. To install, reverse removal procedure, and bleed hydraulic system.

POWER BRAKE UNIT

Removal — Remove master cylinder from vehicle. Disconnect vacuum hose and support unit at power brake unit. Remove power booster attaching hardware, then remove yoke lock nut and yoke. Tilt power booster forward slightly, and remove unit from vehicle.

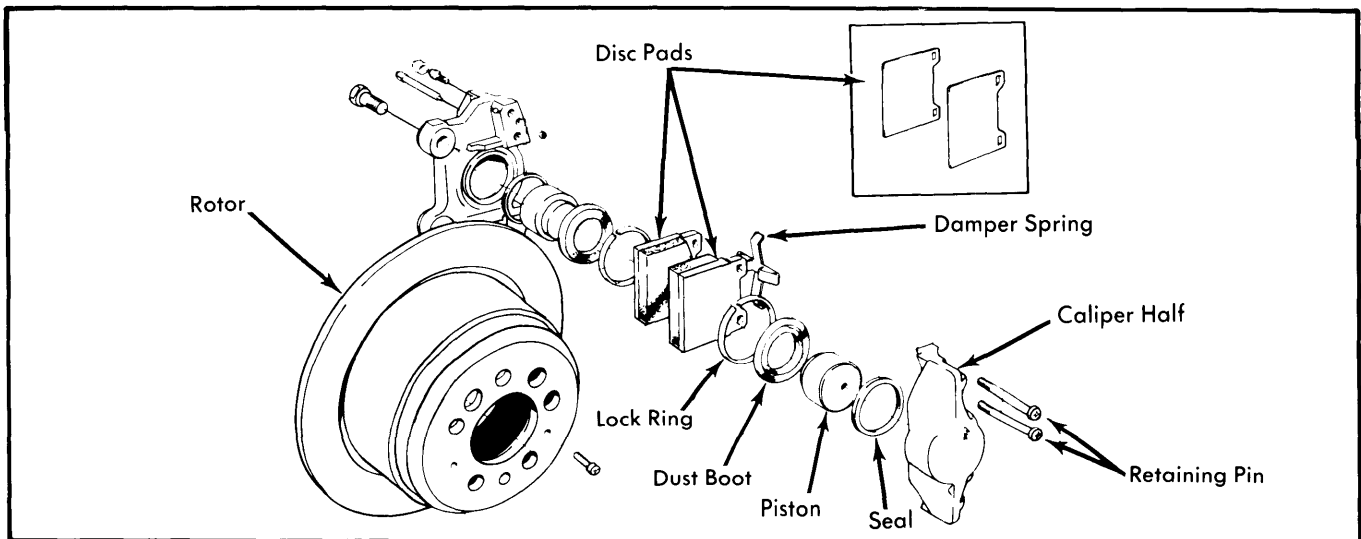

Fig. 4 ATE Rear Caliper Assembly Components

Brakes

VOLVO (Cont.)

Installation — Position power brake unit on vehicle, and attach yoke to push rod. Install and tighten push rod lock nut.

Install and tighten power booster mounting hardware, and install master cylinder to booster. Install vacuum hose, and bleed hydraulic system.

Check Valve Replacement — Remove vacuum hose clamps at check valve, and remove check valve from vehicle. When installing check valve into vacuum hose, install valve with arrow on valve housing pointing toward intake manifold.

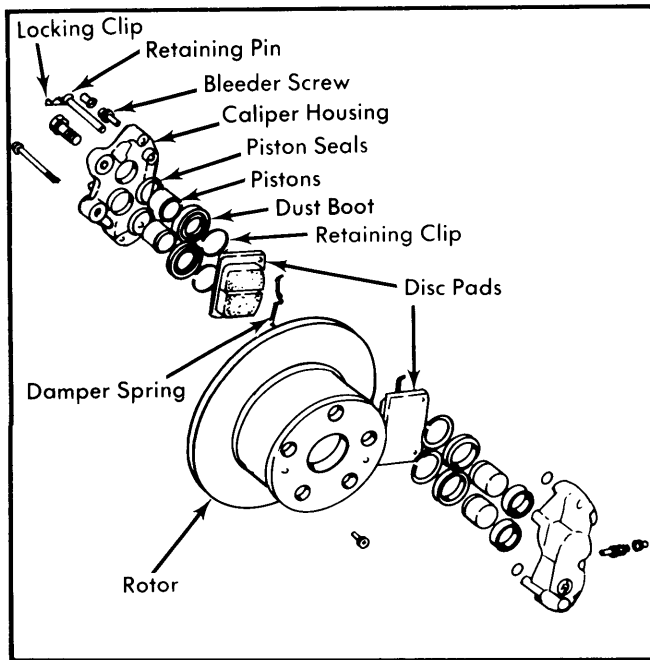

Fig. 5 Girling Front Caliper Assembly

Filter Replacement — Remove power brake unit from vehicle. Remove rubber dust boot, and filter retainer washer. Withdraw silencer and filter from end of booster. To install, reverse removal procedure, making sure slots in filter and silencer are 180° apart.

OVERHAUL

BRAKE CALIPER

Disassembly — Remove caliper from vehicle. Remove disc pads from caliper. Remove piston dust covers and retaining clips. Position a piece of wood between pistons, and carefully apply compressed air at fluid inlet port to force pistons out of cylinder bores. Remove piston seal from cylinder bore, then remove bleeder screw. **NOTE** — DO NOT separate caliper halves.

Inspection — Clean all parts in brake fluid or denatured alcohol. Inspect cylinder bores for scoring, grooving, or corrosion. If any cylinder bore is found to be damaged, replace caliper housing.

Reassembly — Lubricate all parts with clean brake fluid just prior to reassembly. Fit new piston seals in cylinder bore, then

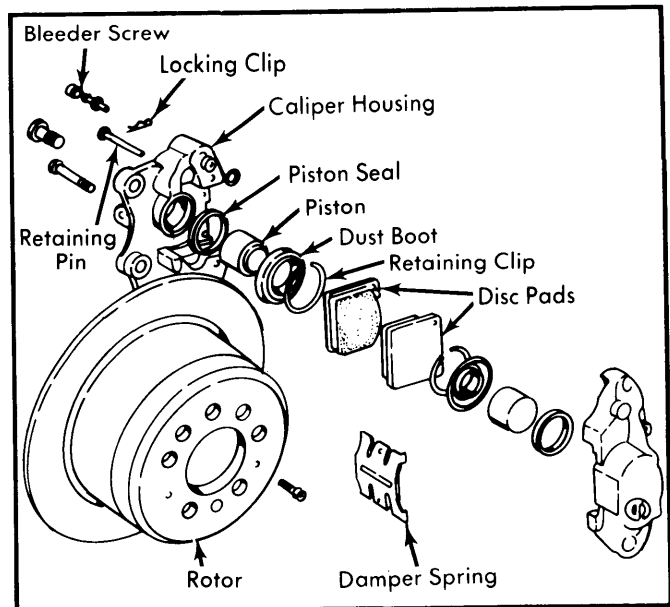

Fig. 6 Girling Rear Caliper

install pistons. On ATE rear brakes, ensure piston is at 20° incline as shown in Fig. 2. Install rubber dust boots and retaining clips. Install bleeder screw, then fit disc pads.

MASTER CYLINDER

Disassembly — Remove master cylinder from vehicle, and clamp mounting flange in a vise. Remove reservoir from cylinder, and remove rubber sealing rings. Remove piston stop screw, and remove retainer ring from end of cylinder bore. Remove pistons from cylinder bore.

Inspection — Clean all parts in clean brake fluid or denatured alcohol and blow dry with compressed air. Inspect cylinder bore for scratches, scoring or corrosion. If cylinder is scored or scratched, it should be replaced.

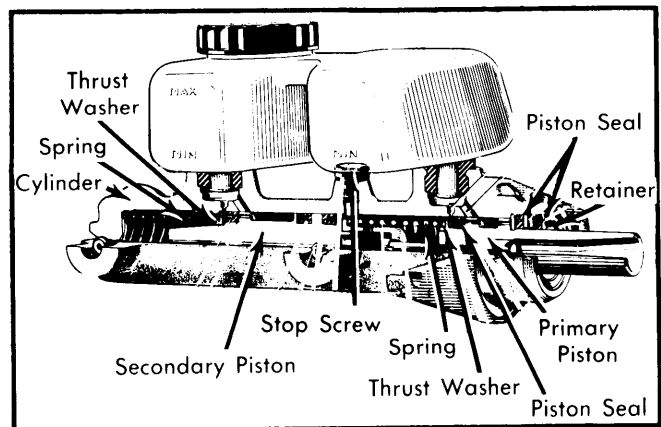

Fig. 7 Master Cylinder Assembly

Reassembly — Lubricate all parts with clean brake fluid prior to reassembly. Position washer, seal, and back-up ring on

VOLVO (Cont.)

secondary piston. Install spring thrust washer on piston, and install piston assembly into cylinder bore. Install washer, seal, and back-up ring on primary piston. Install spring, with plate and sleeve on piston, then install piston assembly into cylinder bore. Push piston into cylinder bore, and install piston stop screw. Install reservoir sealing rings, and install reservoir.

2) Place washer and "O" ring on diaphragm screw. Remember to lightly coat end of screw with suitable thread locking compound. Install diaphragm assembly. Insert valve housing aligned with index marks. Fit valves and seals. Make sure domed side disc faces diaphragm. Install valve housing cover with spring and gasket.

VACUUM PUMP

NOTE — Repair kits are available for valve and diaphragm.

Disassembly — 1) Place pump in soft jawed vise. Index mark valve housing with cover. Remove valve housing. Remove diaphragm, washers, and spring from pump.

2) Turn pump over. Remove bottom cover. Remove actuating lever pin. Slide out pump lever, pump rod and nylon bushing.

Reassembly — 1) Place bushing on pump rod. Put rod in pump housing. Fit lever and pin. Install bottom cover and gasket.

TIGHTENING SPECIFICATIONS

Application	Ft. Lbs. (mkg)
Front Caliper Mounting Bolts	65-70 (9.0-9.7)
Rear Caliper Mounting Bolts	45-50 (6.2-6.9)
Wheel Nuts	70-95 (9.7-13.1)
Master Cylinder Bolts	20-35 (2.8-4.8)
Brake Fluid Lines	6-9 (.83-1.2)

DISC BRAKE ROTOR SPECIFICATIONS

Application	Disc Diameter In. (mm)	Lateral Runout In. (mm)	Parallelism In. (mm)	Original Thickness In. (mm)	Minimum Refinish Thickness In. (mm)	Discard Thickness In. (mm)
240 Front	10.35 (263)	.004 (.10)	.0012 (.03)	.563 (14.3)	.557 (13.14)	...
	Rear	11.06 (281)	.004 (.10)	.0012 (.03)	.378 (9.6)	.331 (8.4)
260 Front	10.35 (263)	.004 (.10)	.0012 (.03)	.95 (24)	.90 (22.8)	...
	Rear	11.06 (281)	.004 (.10)	.0012 (.03)	.378 (9.6)	.331 (8.4)