

TOYOTA

Celica
Corolla
Corona
Cressida
Pickup
Land Cruiser

ADJUSTMENTS

BRAKE PEDAL HEIGHT

All Models (Exc. Land Cruiser) — Loosen stop light switch lock nut and turn switch to obtain correct brake pedal height. If correct height cannot be obtained by adjusting switch, loosen push rod lock nut and lengthen or shorten push rod as necessary to obtain correct height.

DESCRIPTION

All models use front disc brakes and drum rear brakes. Dual piston master cylinders are used on all models. All vehicles are equipped with some kind of pressure differential valve (combination valve). Any model can be fitted with a power assist unit. Not all power units are the same. All parking brakes are cable actuated, internal expanding shoe type. Land Cruiser parking brake is mounted on rear of transfer case, all other models use a parking brake incorporated in rear wheel brakes. Land Cruiser models use a separate vacuum pump to supply vacuum to power assist unit.

Brake Pedal Height

Application	Height In. (mm)
Celica	6.48 (164.5)
Corolla	6.65 (169)
Corona	6.2-6.6 (157-168)
Cressida	6.1-6.5 (156-166)
Pickup	
Man. Trans.	6.3 (160)
Auto. Trans.	6.5 (166)

BRAKE APPLICATION TABLE

Application	Brake System [Ⓛ]
Corona, Corolla (2T-C Eng.), Celica	"F" Type
Corona, Cressida, Pickup	Girling Type
Corolla (3K-C Eng.)	"PS" Type

Land Cruiser — On models with power brake unit, loosen stop light switch and adjust pedal height with push rod. Readjust stop light switch to make proper contact. On models without power brake unit, loosen push rod and adjust pedal height by turning stop light switch.

Ⓛ — Land Cruiser information unavailable.

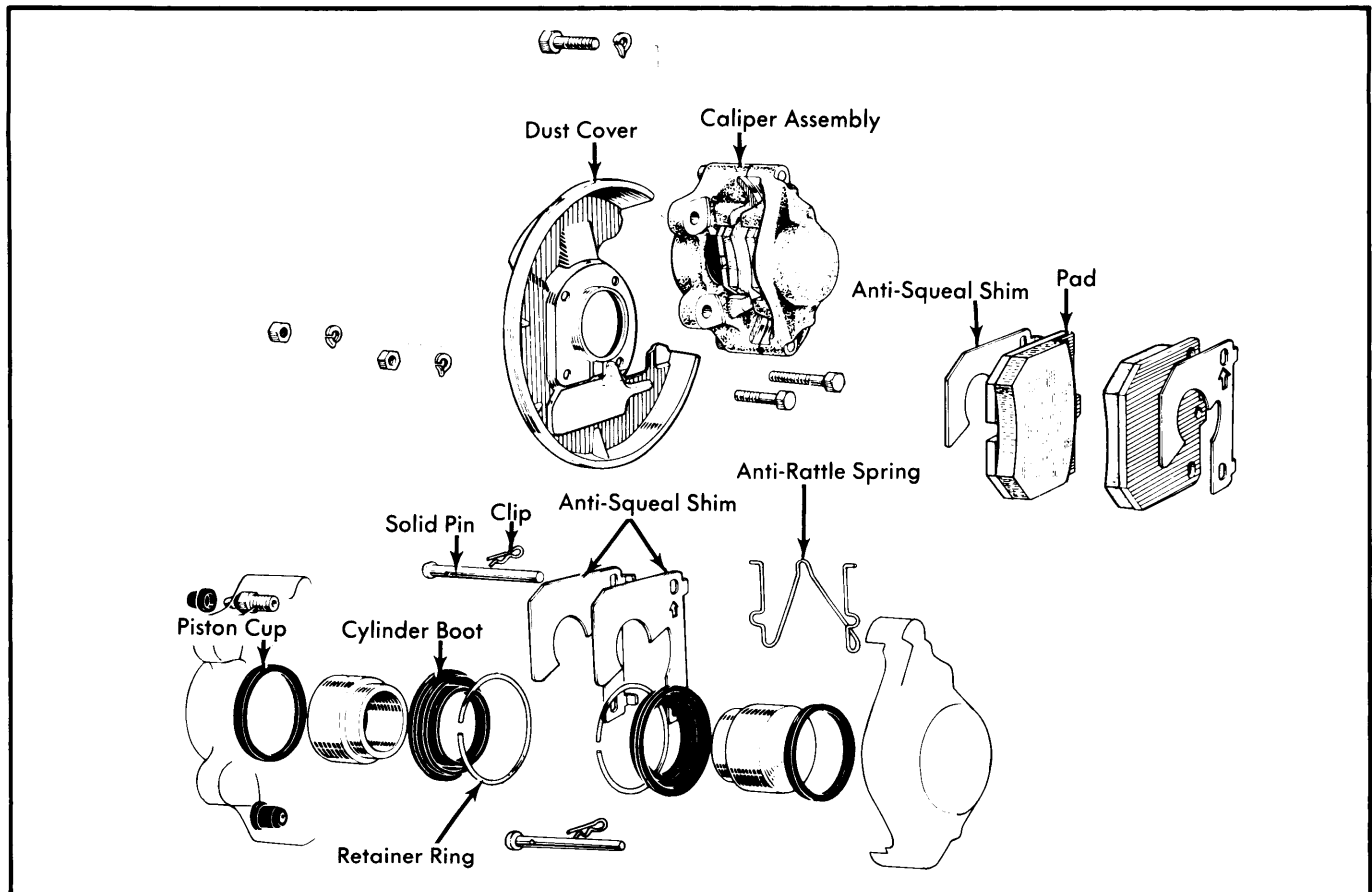

Fig. 1 Exploded View of Girling Type Disc Brake Components

TOYOTA (Cont.)

Brake Pedal Height

Application	Height In. (mm)
FJ40 Series	8.46 (215)
FJ55 Series	7.28 (185)

DISC BRAKES

Disc brakes are self-adjusting; therefore, no adjustment in service is required.

DRUM BRAKES

Manual Adjusting — One or two adjusting screws may be used on some vehicles. **CAUTION** — On double adjusting screw type, do not adjust both screws at the same time. Pump brake pedal several times, and ensure brake cylinder reservoir is full. Raise vehicle and remove adjusting hole plug from backing plate. Using a suitable adjusting tool, turn adjusting screw until shoes make full contact with brake drum, and wheel will not turn. Pump brake pedal, then turn adjuster back until wheel turns with light shoe drag.

PARKING BRAKE

Land Cruiser — With brake handle fully released, turn shaft of adjusting cam (on brake backing plate) counterclockwise until shoe seats against drum. Back off adjuster one notch at a time until drum locks when foot brake is applied, and spins freely when released. After adjusting shoes, adjust brake handle for travel of 6-9 notches from released to applied position. Adjust by turning cable adjusting nut or turnbuckle.

Corolla — Correct adjustment is obtained when rear wheels are locked and brake lever travel is 5-8 notches. To adjust, remove cable adjusting cap at rear of lever and turn cable adjusting nut until correct lever travel is obtained. Replace and lightly tighten adjusting cap. Check and adjust brake warning light switch so that light is off when brake lever is released.

Celica, Corona, Cressida — Fully release parking brake lever. Working under vehicle, loosen brake cable lock nut and tighten turn buckle about 1" (.039 mm). Tighten lock nut. If equipped with "U" shaped cable equalizer, adjust so slack is taken up from cable. Parking brake is properly adjusted when lever travels of 3-8 notches locks rear brakes.

Pickup — With brake handle fully released, turn cable adjusting nut at equalizer on frame until cables to rear wheels are slightly slack and there is no drag on rear wheels. After adjustment, brake handle travel should be about 8 notches and brake warning light should go out. If light remains on, adjust switch position so light goes on when brake is applied and off when handle is released.

BRAKE BLEEDING

NOTE — Master cylinder reservoir(s) must be kept full at all times during bleeding. Starting at wheel cylinder farthest from master cylinder, connect a tube to bleeder screw and put other end of tube in a glass container half full of clean brake fluid. Slowly pump brake pedal several times, then hold pedal in depressed position. Open bleeder screw slightly, and close screw when fluid starts to flow from tube. Repeat procedure until fluid coming from tube shows no signs of air.

REMOVAL & INSTALLATION

DISC BRAKE PADS

Removal, F Type — Raise and support front of vehicle; remove wheel. Pull four spring clips out and remove cylinder guides. Hang disc cylinder assembly out of way. Remove disc pads and inspect for wear.

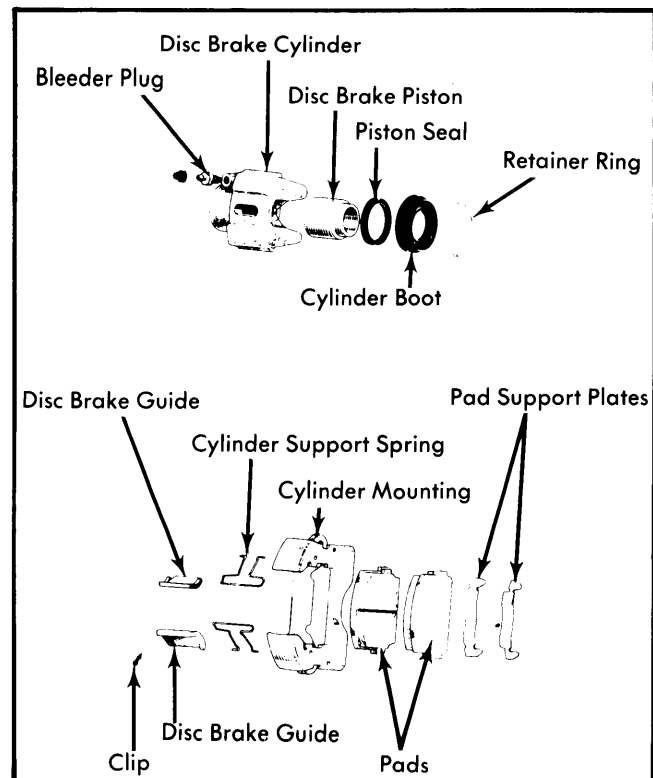

Fig. 2 Expanded View of F Type Disc Brake Components

Installation — Clean piston and cylinder assembly, then seat piston into cylinder bore. If piston won't easily reseat into cylinder bore, crack bleed valve to relieve pressure. Insert cylinder assembly into position. Refit new disc pads, cylinder guides, and spring clips. If hydraulic line has been disconnected, bleed brake system.

Removal, Girling Type — Raise and support front of vehicle; remove wheel. Remove clips, pins, and springs; then take out pads and anti-squeal shims. If vehicle is equipped with Electrical Sensor Panel, separate wire harness from steering knuckle wire harness clamp. Pull out pads and separate connection between pad and wear sensor.

Installation — Install by fitting anti-squeal shim so folded portion will be facing pad and arrow will face in direction of rotation. If ESP equipped, mount wear sensor in inner side pad before installing pad. Install springs, pins, and clips. Refit ESP wiring, ensuring wiring harness is not kinked.

Brakes

TOYOTA (Cont.)

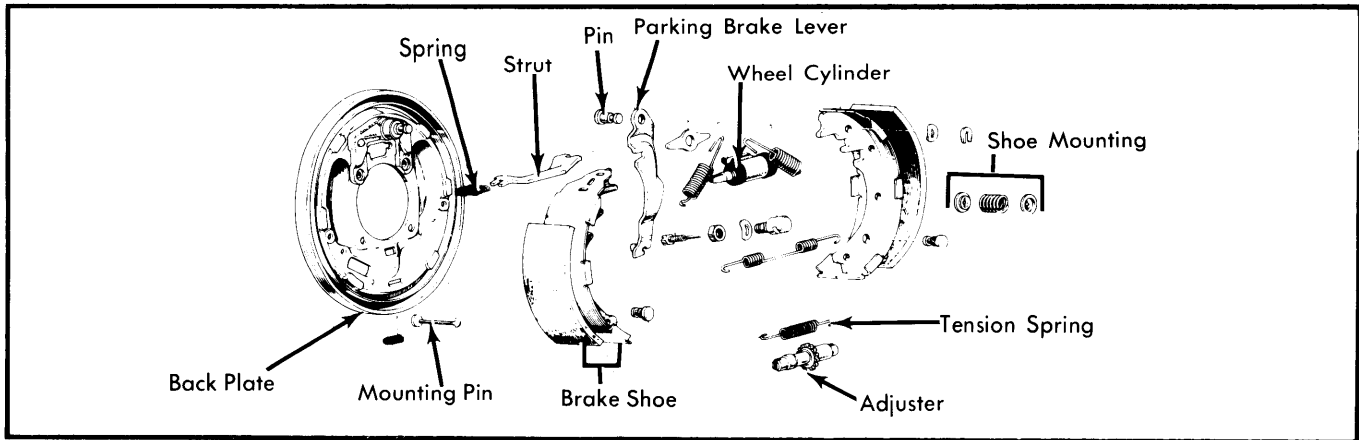

Fig. 3 Exploded View of Toyota Pickup Rear Brake Assembly

Removal & Installation, PS Type — Raise and support front of vehicle; remove wheel. Take out pad protector, anti-rattle springs, spring pins, and pads. Clean dirt from pin portion of torque plate. After cleaning piston assembly, seat into cylinder bore. Insert pads and install retaining pins, anti-rattle springs, and protector.

Installation — To install, reverse removal procedure and note: Tighten mounting bolts. Make sure brake tube is properly seated and that anti-rattle spring is tight.

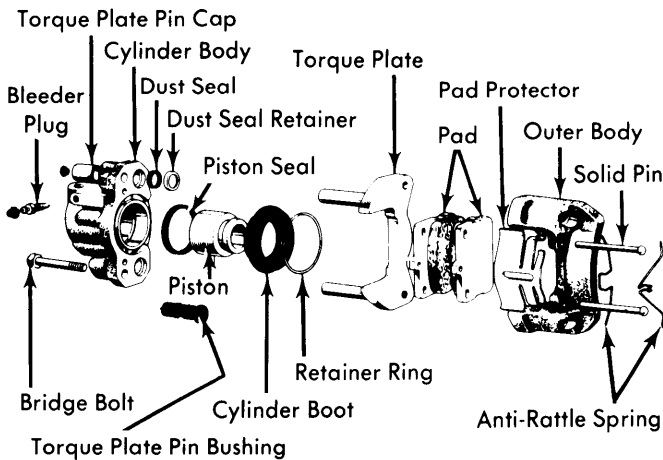

Fig. 4 Exploded View of PS Type Disc Brake Assembly

FRONT DISC CALIPER & PADS

Removal, Land Cruiser — Raise and suitably support front of vehicle. Disconnect and plug brake fluid line and inlet port. Remove caliper mountings and lift off rotor. Remove clip, mounting pin, and anti-rattle spring. Pull disc pads from caliper cavity.

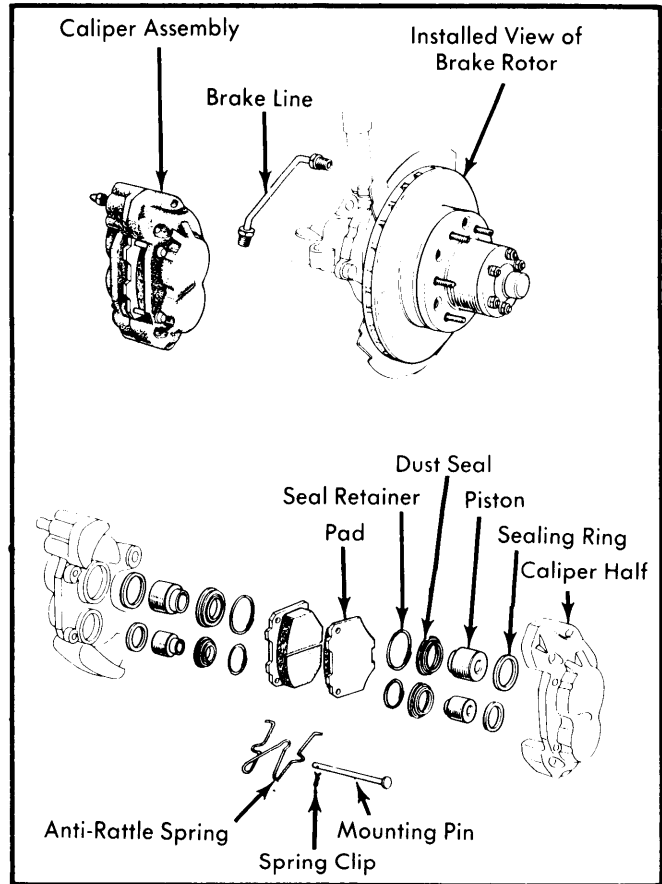

Fig. 5 Exploded View of Land Cruiser Front Disc Brakes

Inspection — Wipe all dirt from caliper cavity and look for possible leaks. Replace disc pads if worn beyond .039" (1 mm).

DISC BRAKE CALIPER

Removal, F Type — Raise and support front of vehicle; remove wheel. Pull four clips out and remove cylinder guides.

TOYOTA (Cont.)

Hang disc cylinder assembly out of way. Remove disc pads. Remove two bolts from rear of disc brake cylinder mounting and remove mounting along with cylinder support springs and pad support plates.

Installation — To install F type brake caliper, reverse removal procedure and note the following: It may be necessary to manually seat piston in cylinder bore to ease installation. Ensure cylinder guides and clips are in good condition.

Removal, All Others — Raise and support front of vehicle; remove wheel. Remove disc brake pads as previously outlined. Disconnect hydraulic fluid line from caliper inlet port. Remove caliper mounting bolts and carefully lift off caliper assembly.

Installation — To install, reverse removal procedure and note the following: Ensure caliper mounting bolts are properly torqued. Make sure disc pads are installed according to previously outlined procedure.

DISC BRAKE ROTOR

Removal, Except Land Cruiser — Raise and support vehicle; remove tire. Before removing rotor, measure runout and check against specifications. Proceed by removing hub grease cap, cotter pin, washer, and castle nut; carefully ease outer wheel bearing from hub. Remove caliper assembly as previously outlined. Pull hub and rotor from vehicle as an assembly. If necessary, hub and rotor can be further disassembled after index marking relationship.

Installation — To install hub and rotor assembly, reverse removal procedure and note the following: Ensure wheel bearings are packed with grease and that wheel bearing grease seal is satisfactory. Make sure wheel bearings are properly adjusted. See *Wheel Bearing Adjustment* in *WHEEL ALIGNMENT* Section.

Removal, Land Cruiser — Remove caliper assembly as previously outlined. Remove hub grease cap and take off snap ring. Remove cover nuts, washers and cone washers. Using suitable socket or wrench SST 09607-60020, remove lock nut, lock washer and wheel bearing adjusting nut. Slide off rotor and hub assembly. If necessary, index mark rotor and hub, then separate.

Inspection — Before rotor removal check runout. Set up dial indicator, remove play from wheel bearings, and take measurement. Runout must not exceed .005" (.13 mm). With rotor removed, measure thickness. Rotor thickness must not be less than .790" (20 mm).

Installation — To install, reverse removal procedure and note: Adjust wheel bearings. See *Wheel Bearing Adjustment* in *WHEEL ALIGNMENT* Section.

BRAKE DRUM

Removal, All Models Rear — Raise and support rear of vehicle; remove wheel. Remove set screws from brake drum, if equipped. Using hands only, pull drum from vehicle. It may be necessary to first loosen brake shoes if an adjustment hole is provided.

Installation — To install, reverse removal procedure and readjust brake shoes, if necessary.

BRAKE SHOES

Removal, All Models Rear — Raise and support vehicle. Remove wheel and brake drum. Remove parking brake cable from lever, and remove tension springs from shoes. Remove self-adjuster mechanism (if equipped). Remove shoe guide plate, shoe hold down pins and springs. Take out parking brake strut. Remove brake shoes from backing plate. Remove parking brake actuating lever, self-adjusting lever, and latch from brake shoe.

Installation — To install, reverse removal procedure and bleed hydraulic system.

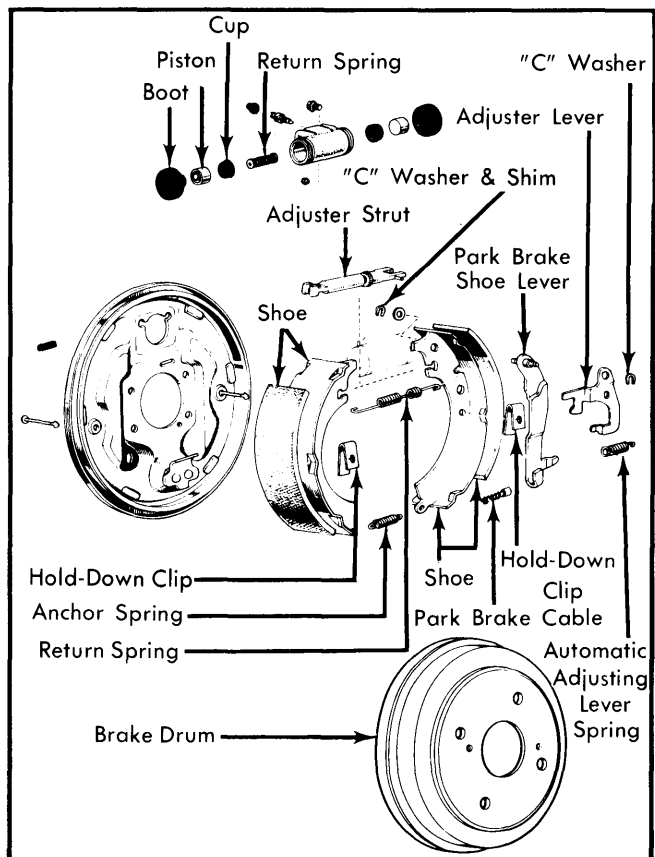

Fig. 6 Exploded View of Cressida Rear Brake Assembly with Automatic Adjuster Lever Shown

PARKING BRAKE

Removal, Land Cruiser — Drain oil from transfer case. Disconnect front of drive shaft and wire out-of-way. Remove drum mounting nut and slide drum off splines. Remove return springs and tension springs, then take off hold down springs and pins. Disconnect parking brake cable from shoes.

Inspection — Inspect shoes for excessive damage or wear. Replace shoes when lining thickness is less than .06" (1.5 mm).

TOYOTA (Cont.)

Installation — To install, reverse removal procedure and note: Make sure lower tension spring is installed so it lies between back plate and shoes. Refill transfer case with 1.8 quarts of SAE 90. Tighten drum mounting nut.

VACUUM PUMP

Removal, Land Cruiser — Disconnect vacuum line from pump assembly. Disconnect and plug oil lines. Remove mounting nuts and gently pry pump off studs.

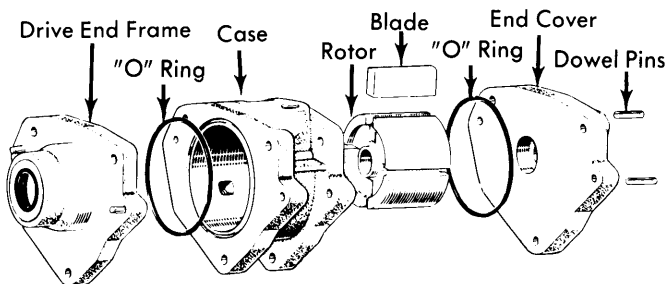

Fig. 7 Exploded View of Vacuum Pump for Land Cruiser

Installation — To install, reverse removal procedure and note: Run engine at idle speed. Loosen screw at vacuum pump outlet and check that oil is circulating.

MASTER CYLINDER

Removal, All Models — Disconnect any electrical lead from master cylinder switches. Separate hydraulic outlet lines and plug open ends of line. Remove nuts mounting master cylinder to power unit, if equipped. If vehicle is not power brake equipped, disconnect master cylinder push rod and lift from vehicle.

Installation — To install, reverse removal procedure and bleed hydraulic system.

POWER BRAKE UNIT

Removal & Installation — Remove master cylinder assembly from vehicle. Disconnect push rod clevis at brake pedal. Remove power booster attaching hardware, and remove booster assembly from vehicle. To install, reverse removal procedure.

OVERHAUL

NOTE — When overhauling caliper, wheel cylinder, or master cylinder assemblies, all rubber components should be replaced. If cylinder bores in any part are pitted, or scored more than light honing will repair, entire assembly should be replaced.

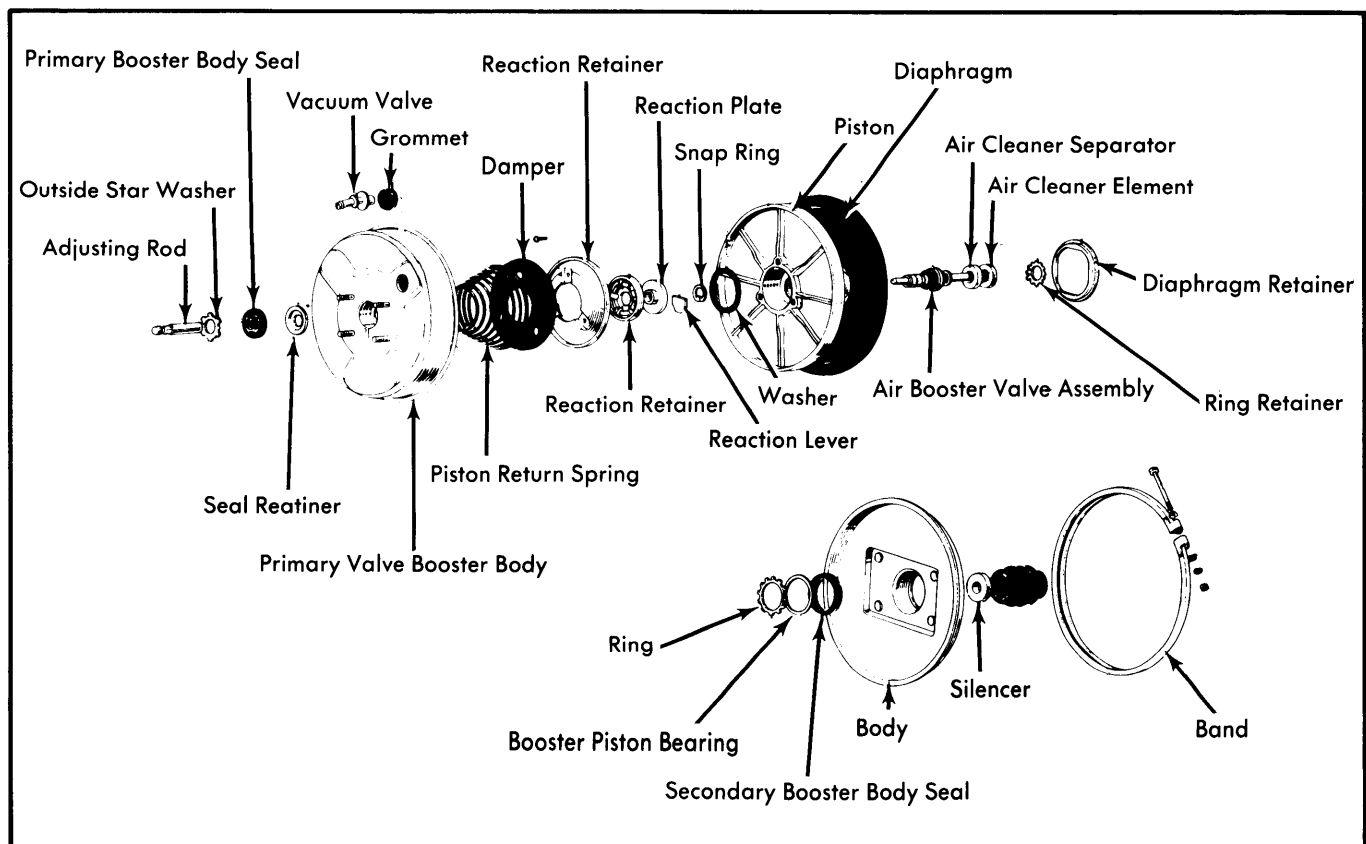

Fig. 8 Exploded View of ASCO Type Brake Booster Unit

TOYOTA (Cont.)

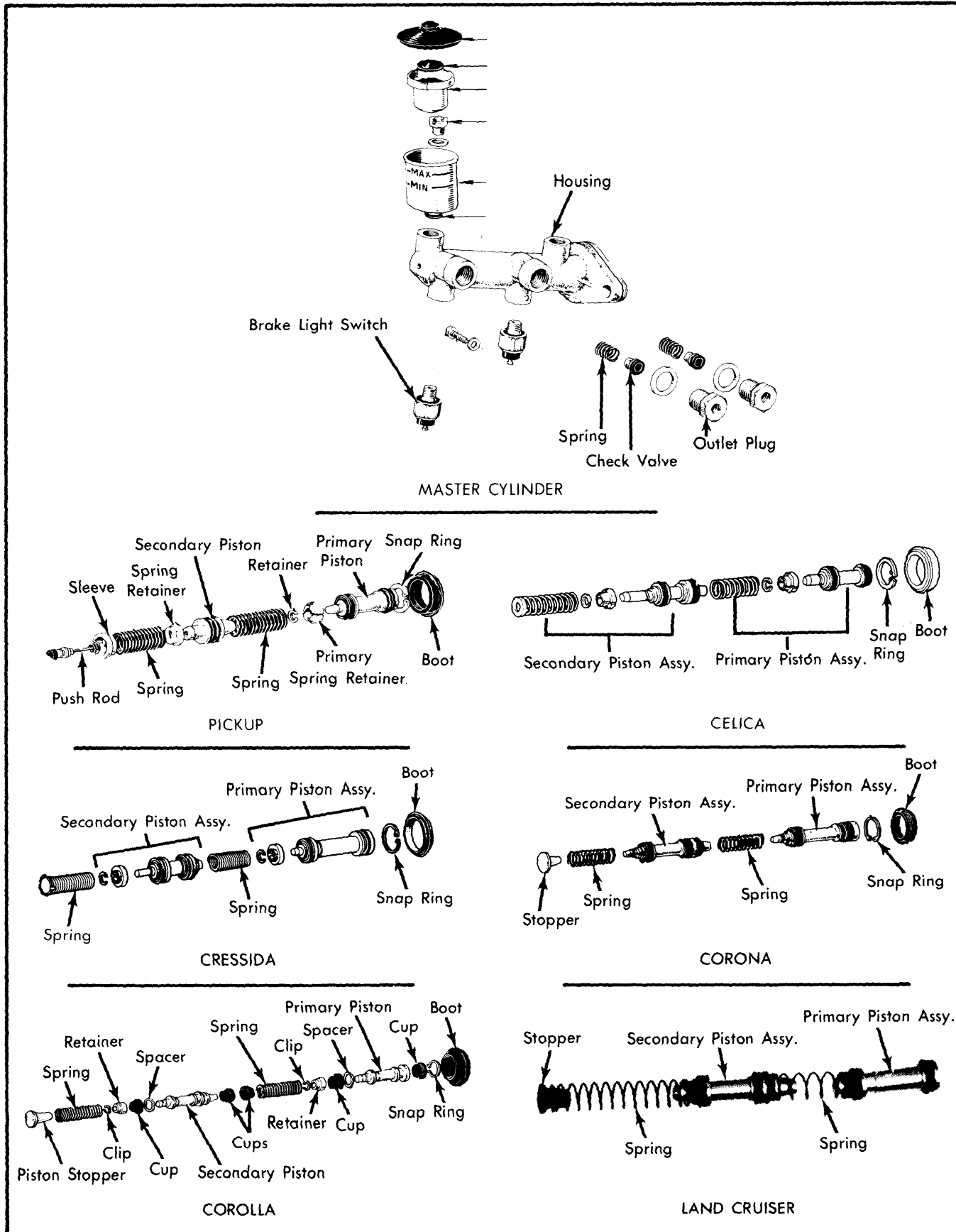

Fig. 9 Exploded View of Typical Master Cylinder Body and Detail of Each Model Primary and Secondary Piston Assemblies

TOYOTA (Cont.)

DISC BRAKE CALIPER

Disassembly, F Type — Remove retainer ring and take off cylinder boot. Apply light air pressure to fluid inlet port and force piston from cylinder. Remove seal from cylinder, being careful not to damage cylinder bore.

Inspection — Clean and inspect all components. Replace any parts found defective.

Reassembly — To reassemble, reverse disassembly procedure and note the following: Apply light coat of suitable grease/brake fluid to all components before reassembly. Bleed hydraulic system after installation.

Disassembly, Girling Type — Remove retainer ring from dust boot and pull off dust boot. Insert a small block of wood between pistons and apply light air pressure to inlet port to force pistons from cylinder bores. Remove seals from grooves in cylinder bores. **NOTE** — Do not separate caliper halves.

Inspection — Clean and inspect all components. Replace any parts found defective.

Reassembly — Lightly coat all components with brake fluid, then insert seal into cylinder bore groove. Carefully push pistons into cylinder, install rubber dust boots and retainer rings.

Disassembly, PS Type — Loosen both bridge bolts (caliper half mounting bolts) and separate cylinder casting from outer body. Pull out torque plate. Remove retainer ring and dust boot. Force light air pressure through fluid inlet port and expel piston. From caliper, remove following: Piston seal, bushings, hole plug, retainers and dust seals.

Inspection — Inspect all parts for wear or damage and replace as necessary. If torque plate pins are excessively worn or if pin weld parts are abnormally corroded, caliper must be replaced.

Reassembly — 1) Lightly coat all parts prior to reassembly with clean brake fluid. Fit dust seal, retainers, and bushings to cylinder. Ensure pin sliding surfaces and bushing bores are clean and smear with suitable grease from repair kit.

2) Fit piston seal on cylinder and push piston in by hand. Install dust boot and ring. Reassemble torque plate pins in cylinder body. Make sure torque plate is free to slide smoothly. Install bridge bolts and torque.

Disassembly, Land Cruiser — Remove caliper assembly and take out disc pads. Remove dust seal retainer ring and dust seal. Place a small block of wood into caliper cavity. Blow compressed air into brake fluid inlet port until piston is forced out; repeat procedure on opposite side. Using a pointed, but blunt tool, dig piston seal from caliper groove. **NOTE** — Do not separate caliper halves.

Inspection — Check cylinder bore and piston for excessive wear, damage or corrosion; replace parts as necessary. Inspect pad thickness, pad must not be worn beyond .039" (1 mm).

Reassembly — Lightly coat all components with brake fluid. Insert new piston seal, being careful that seals properly enter grooves. Fit piston and slide dust seal into position. With dust seal seated, fit retainer ring.

MASTER CYLINDER

Disassembly, All Models — Remove pressure switches and clamp cylinder flange in a soft jawed vise. Remove unions and bolts, outlet plugs, valves, and springs. Remove push rod boot. Take off snap ring, then remove push rod and rear piston assembly. Remove stop bolt from side of cylinder and remove front piston. Remove inlet valve seat and inlet valve. Disassemble pistons by removing springs, retainers, and cups.

Reassembly — To reassemble, reverse disassembly procedure using all new rubber parts and lubricating all components with clean brake fluid.

WHEEL CYLINDER

NOTE — Removal of wheel cylinder from backing plate is not necessary, except when replacement of cylinder assembly is required.

Disassembly — Remove adjuster lock spring and adjuster (if equipped). Remove bleeder screw. Remove cylinder boot(s), piston(s), cup(s), spring seat (if equipped), and spring.

Inspection — Clean all parts with solvent, and blow dry with compressed air. Check cylinder bore for out-of-round, corrosion, or scoring.

Reassembly — To reassemble, reverse disassembly procedure, using new rubber parts.

VACUUM PUMP

Disassembly, Land Cruiser — Drive dowel pins from end cover toward case. Separate end cover. Continue to drive dowels through case and stop with them flush with end frame. Remove end frame with pins still fitted. Remove both "O" rings and discard. Slide rotor and blades from case.

Inspection — Inspect end cover and casing for damage or wear. Casing bore must not be worn beyond 2.29" (5.82 mm). Check rotor-to-alternator shaft spline play. Rotor wear must not exceed .095" (2.4 mm). Inspect rotor blades for following wear limits: Height .47" (12 mm); length 1.377" (34.98 mm); width .036" (.92 mm). Check end frame bushing and oil seal. Bushing bore must not exceed .635" (16.14 mm). Replace oil seal by prying out and pressing in new one.

Reassembly — Lightly coat new "O" rings and insert into grooves. Refit rotor and blades. Drive in dowel pins.

POWER BRAKE UNIT

Disassembly, ASCO Type — Remove booster push rod. Remove clamping band and separate primary and secondary booster body halves. Remove boot and booster piston assembly from secondary body half. Remove outside star washer from secondary body and remove bearing and body seal. From primary body, remove seal and retainer. Disassemble booster piston by removing reaction retainers, lever, air valve, air cleaner element and separator. Using suitable remove tool (SST 09736-30020), take out diaphragm rotating it 45°, then remove diaphragm from piston. Remove vacuum check valve and grommet from booster body.

TOYOTA (Cont.)

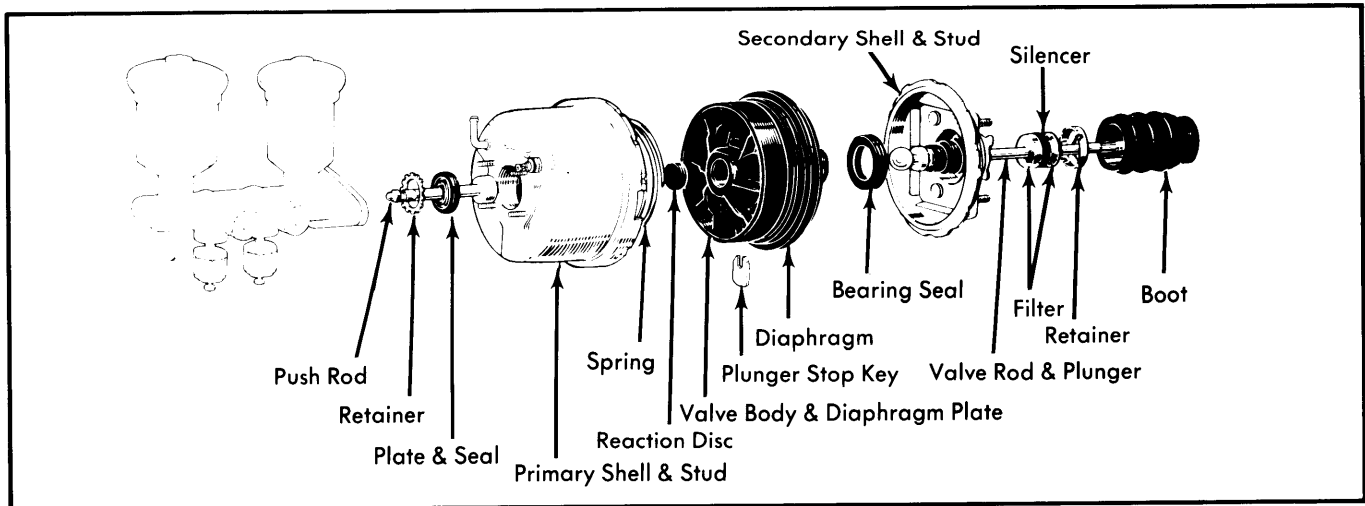

Fig. 10 Exploded View of JKK Brake Booster Unit

Inspection – Wash all parts in suitable cleaner. Inspect all components for excessive wear or damage and replace those that are found damaged.

Reassembly – To reassemble, reverse disassembly procedure and note the following: When assembling booster body seal to seal retainer, ensure seal retainer side is in the body inner side. When assembling body halves, align index marks.

Disassembly, JKK Type – Remove push rod clevis, nut, and boot. Index mark primary and secondary shell halves. Separate halves using suitable tool (SST 09738-22012). Remove diaphragm spring and push rod. Take out diaphragm plate and diaphragm spring from secondary shell half.

Disengage the diaphragm from plate, then remove silencer. Remove plunger stop key by lining up valve rod and plunger toward key hole with pieces facing downward; then remove valve and plunger rod from diaphragm plate. **NOTE** – Valve rod and plunger assembly can not be further disassembled. Remove reaction disc from diaphragm plate. If necessary, remove retainer and seal from primary shell. With a press, force bearing seal from secondary shell.

Inspection – Wash all parts in suitable cleaner. Inspect all components for any damage and replace those found defective. Ensure all rubber pieces are replaced during each overhaul.

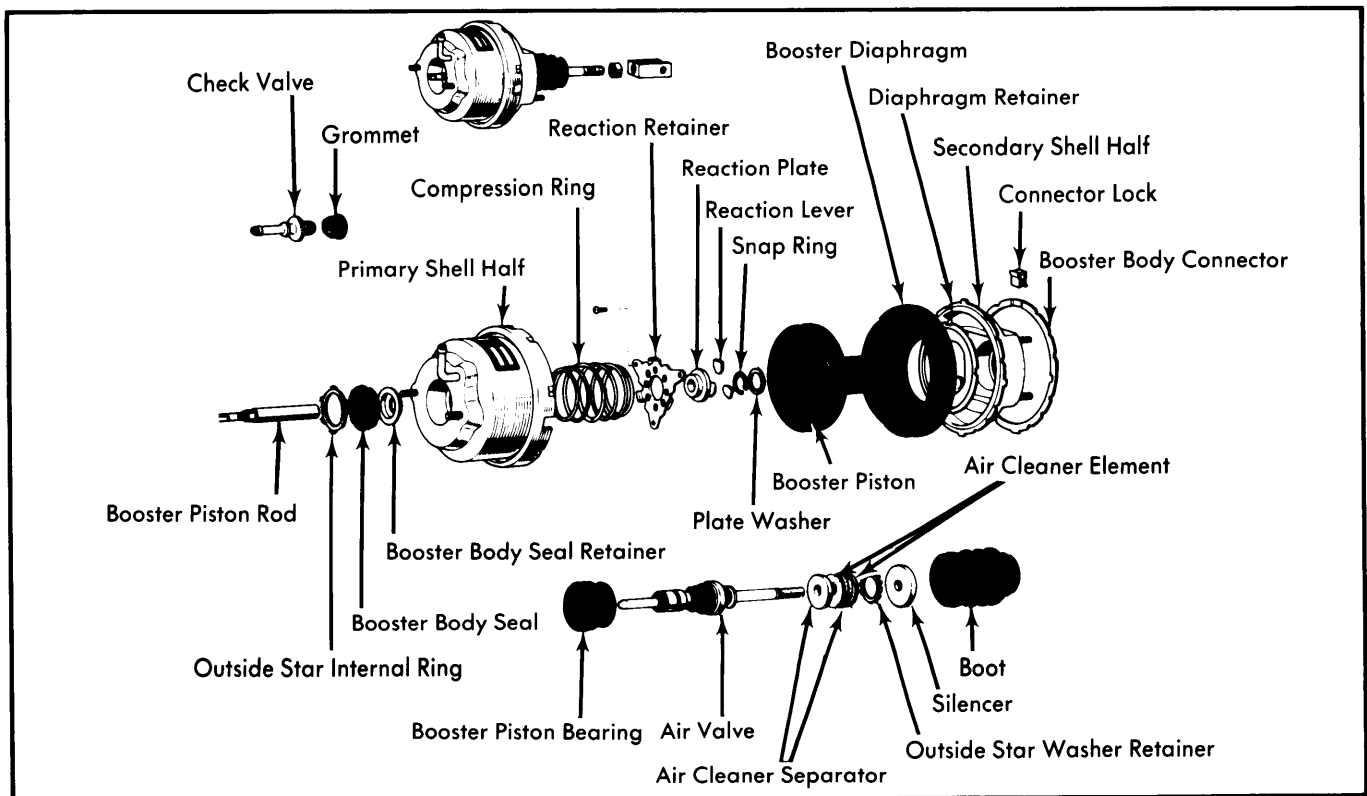

Fig. 11 Exploded View of Aisan Type Brake Booster Assembly

Brakes

TOYOTA (Cont.)

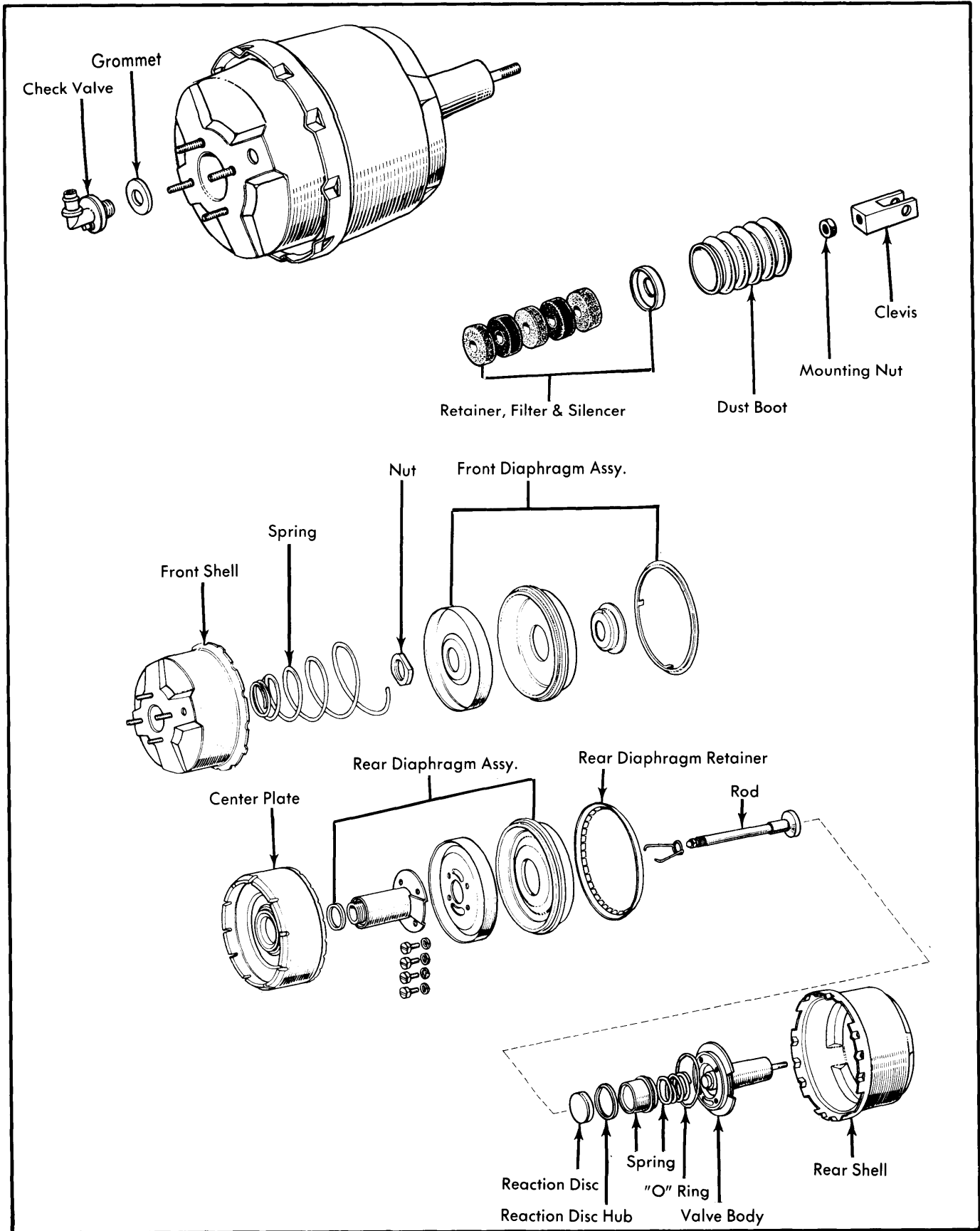

Fig. 12 Exploded View of Land Cruiser Power Brake Booster Assembly

TOYOTA (Cont.)

Reassembly — To reassemble, reverse disassembly procedure and note the following: Ensure retainer is fully seated in secondary shell half. Properly locate plunger key stop. Coat reaction disc with silicon grease. Make sure diaphragm edge has oil coating before final tightening.

Disassembly, Aisan Type — 1) Remove booster push rod, clips mounting booster body connector, and push rod clevis. Using suitable tool (SST 09738-20010) and a press, apply pressure to body; then turn booster body connector until slots (and body halves) are disengaged.

2) Remove the following from secondary shell half: Boot, booster piston assembly, and bearing. From primary shell side, remove outside star washer retainer ring and body seal.

3) Disassemble following parts from front of booster piston: Reaction retainer, plate, lever, and snap ring. From rear of booster piston take off: Mounting ring, air cleaner elements, separators and booster air valves. Remove diaphragm retainer using suitable tool (SST 09736-30020) and rotating retainer 45°. Take off diaphragm from piston.

Inspection — Wash all parts in suitable cleaner. Inspect all components for any damage and replace those found defective.

Reassembly — To reassemble, reverse disassembly procedure and note the following: Ensure that seal retainer is assembled to inner primary shell. Make sure when assembly is installed on dash panel, sunken part of primary body will be positioned downward.

Disassembly, Land Cruiser — Remove check valve and rubber grommet. Take off clevis mounting nut and withdraw

clevis, rubber dust boot, retainer, and filter/silencer assembly. Using a suitable tool (SST 09738-22012 & 09753-22010), separate front shell housing and diaphragm spring. Remove diaphragm nut and diaphragm retainer, then slide assembly apart. Remove hub bolts and take off rear diaphragm plate. Reaction disc assembly can now be removed along with valve body and "O" ring.

NOTE — Index mark front and rear diaphragms. Also, index mark front and rear shells for reassembly.

Inspection — Inspect shell cylinder, diaphragms, and center plate for cracks, damage or wear. Apply silicone grease to front and rear shell seals.

Reassembly — Reverse disassembly procedure and note: Fit reaction disc with protrusion directed toward valve body. Position center plate on hub with large groove facing front side. Make sure that front and rear shells are aligned with index marks. Adjust push rod length to .004-.020" (.1-.5 mm)

TIGHTENING SPECIFICATIONS

Application	Ft. Lbs. (mkg)
Caliper Mounting Hardware	
Land Cruiser, Cressida, Corona (Girling)	67-86 (9.3-11/9)
Celica, Corolla (2T-C)	40-54 (5.5-7.5)
Corolla (3K-C)	29-40 (4.0-5.5)
Rotor-to-Hub	20-40 (4.0-5.5)
Brake Drum Backing Plate	43-53 (6.0-7.3)
Bridge Bolt (Corolla (2T-C)	58-69 (8.0-9.5)

DISC BRAKE ROTOR SPECIFICATIONS ①

Application	Disc Diameter	Lateral Runout	Parallelism	Original Thickness	Minimum Refinish Thickness	Discard Thickness
Celica F Type006 (.15)492 (12.5)	.453 (11.5)
Corolla F Type & PS Type006 (.15)394 (10)	.354 (9.0)
Corona F Type006 (.15)492 (12.5)	.453 (11.5)
Girling Type006 (.15)492 (12.5)	.453 (11.5)

① — All measurements given in inches with millimeters in parens.

Brakes

TOYOTA (Cont.)

DISC BRAKE ROTOR SPECIFICATIONS						
Application	Disc Diameter In. (mm)	Lateral Runout In. (mm)	Parallelism In. (mm)	Original Thickness In. (mm)	Minimum Refinish Thickness In. (mm)	Discard Thickness In. (mm)
Cressida, Pickup Girling006 (.15)492 (12.5)	.453 (11.5)
Land Cruiser0047 (.12)790 (20.1)	.740 (19)

BRAKE DRUM SPECIFICATIONS				
Application	Drum Diameter In. (mm)	Original Diameter In. (mm)	Maximum Refinish Diameter In. (mm)	Discard Diameter In. (mm)
Corolla (3K-C)	7.87 (200)	7.87 (200)	7.953 (202)
Corolla (2T-C), Celica, Corona, Cressida	9.0 (228.6)	9.0 (228.6)	9.079 (230.6)
Pickup	10.0 (254)	10.0 (254)	10.078 (256)
Land Cruiser	11.50 (292)