

OPEL

All Models

DESCRIPTION

Brake system has a two-part circuit. Front brakes are one circuit, consisting of a dual piston caliper and a rotor. Leading-trailing, rear drum brakes make up other circuit. Drum brakes are self-adjusting. A dual piston master cylinder supplies the hydraulic pressure for brake system. Some models may be equipped with a Master-Vac power brake unit. All models are fitted with a mechanical parking brake. Control handle for parking brake is mounted between front seats and, when actuated, locks rear wheels.

ADJUSTMENT

DISC BRAKES

Disc brakes are self-adjusting.

DRUM BRAKES

Rear drum brakes are self-adjusting.

PARKING BRAKE

1) Adjustment is required when service brakes are working properly but parking brake handle must be pulled excess of eight notches to lock rear wheels.

2) Release parking brake and check cable for free movement. Take up cable slack by turning adjusting nut at yoke connection until lever travel is from five to eight notches.

PEDAL HEIGHT

Turn brake pedal push rod until pedal height is approximately $6\frac{3}{4}$ " (171 mm). Adjust stop light switch so brake pedal free play is eliminated. Tighten lock nuts.

HYDRAULIC SYSTEM BLEEDING

NOTE — To avoid damage to push rod seal, engine must be running during bleeding operation.

Attach a bleeder tube to bleeder screw and immerse opposite end of tube in a container partially filled with brake fluid. Open bleeder screw and allow pedal to be pushed through its full travel. Close bleeder screw and let pedal return to normal height. Continue procedure until all air is expelled from cylinder. Repeat bleeding procedure at remaining wheels.

REMOVAL & INSTALLATION

FRONT DISC BRAKE PADS

Removal — Raise vehicle and support on safety stands. Remove spring clips, mounting pins, damper ("M") spring, pad shims, and disc pads. Inspect pads for wear or damage and replace pads if worn beyond .067" (1.70 mm). Inspect caliper cavity for leaks. **NOTE** — All pads must be replaced at one time.

Installation — Seat piston into caliper bore using tool J-22430 (or equivalent). Fit anti-squeal shims to disc pads with arrow facing in direction of normal disc rotation. Fit damper ("M") spring and insert mounting pins. Install mounting pin spring clips.

FRONT DISC BRAKE CALIPER

Removal — Raise and suitably support vehicle. Remove wheel. Disconnect and plug caliper brake line. Remove mounting bolts and lift off caliper.

Installation — To install caliper assembly, reverse removal procedure. Bleed hydraulic system.

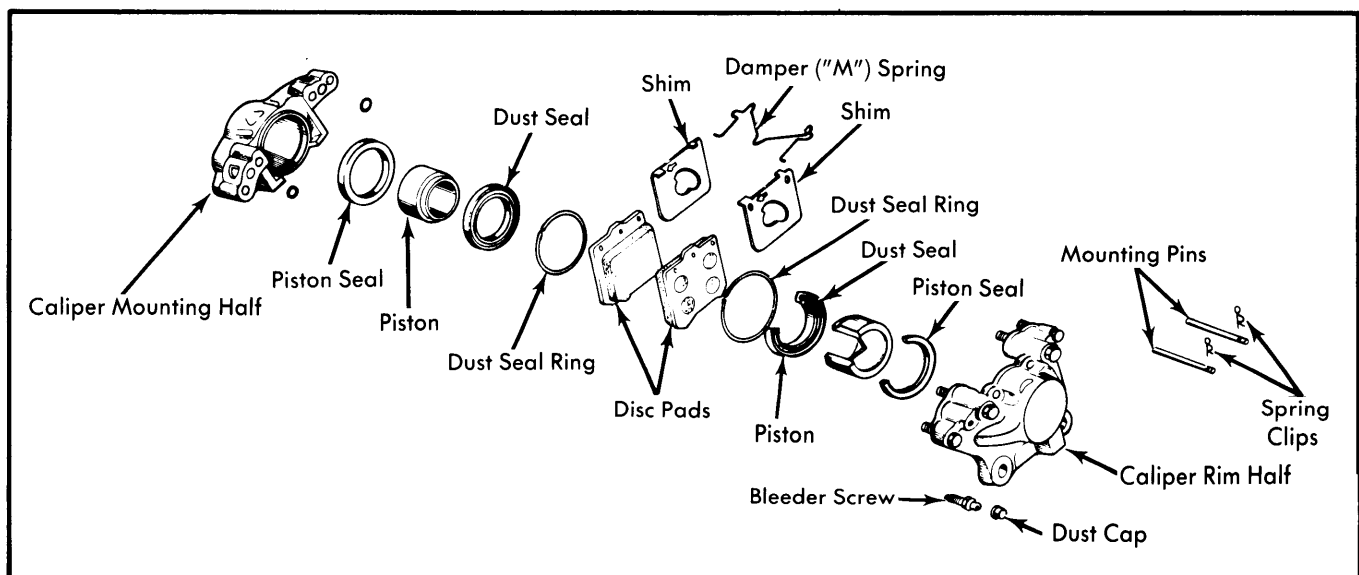

Fig. 1 Exploded View of Opel Front Disc Brake Assembly

OPEL (Cont.)

FRONT DISC BRAKE ROTOR

Removal — Raise and suitably support vehicle. Remove wheel. Remove caliper without disconnecting brake fluid line. Suspend caliper from upper control arm using a wire hanger. Remove grease cap and take out the outer wheel bearing assembly. Pull hub and rotor assembly from spindle. Remove bolts mounting rotor to hub and index mark before separating.

Installation — To install, reverse removal procedure and note the following. Make sure wheel bearings are properly tightened. See *Wheel Bearing Adjustment in WHEEL ALIGNMENT Section*. Measure brake rotor runout. If runout exceeds .006" (.15 mm), resurface or replace rotor.

REAR BRAKE SHOES

Removal — Raise and suitably support vehicle on safety stands. Remove wheel and drum. Remove return springs, shoe hold down pins, retainers and springs. Fully expand adjuster mechanism and disconnect strut. Remove primary shoe. Disconnect parking brake lever from cable; then remove secondary shoe. If necessary, wheel cylinder can now be removed.

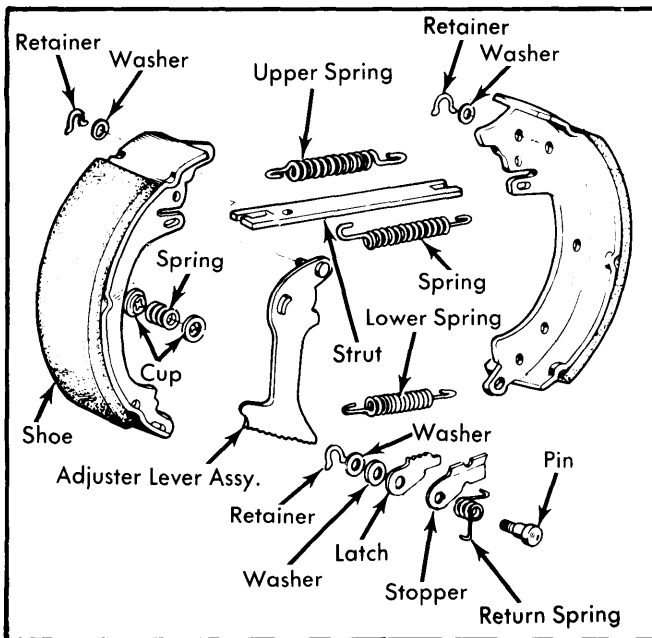

Fig. 2 Exploded View of Rear Brake Assembly

Installation — To install brake shoes, reverse removal procedure and note the following: Make sure brake shoes do not scratch wheel cylinder boots during installation. Halves of adjuster mechanism are not reversible. Right and left side self-adjuster components are not interchangeable.

MASTER CYLINDER

Removal — Disconnect front and rear brake lines from master cylinder. Take off nuts mounting cylinder to power brake unit support bracket. Separate brake fluid reservoir bracket and lift off master cylinder assembly complete with fluid reservoir and hoses.

Installation — To install master cylinder, reverse removal procedure.

POWER BRAKE UNIT

Removal — Remove master cylinder as previously outlined. Disconnect vacuum hose from check valve. Remove clevis pin and brake pedal arm. Remove nuts mounting power brake unit to fire wall spacer and lift unit from vehicle.

Installation — To install, reverse removal procedure and note the following: Adjust push rod length to .733" (18.6 mm). Adjust brake pedal height as previously outlined.

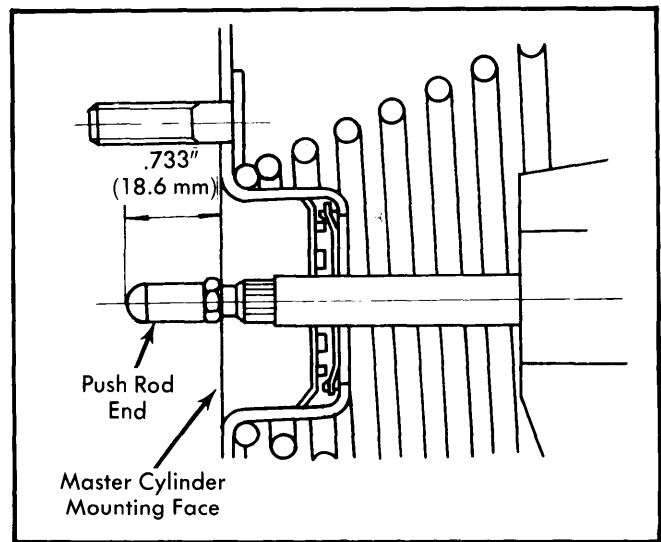

Fig. 3 Power Brake Unit Push Rod Measurement Points for Adjustment

OVERHAUL

FRONT DISC BRAKE CALIPER

Disassembly — Remove each piston dust seal ring, then take out dust seal. Fit clamp J-2242 (or equivalent) to caliper mounting half piston, then force air pressure into fluid inlet to push rim half piston from caliper bore. Repeat procedure on opposite side to remove other piston. Remove seals from grooves in piston bores. **NOTE** — Use a pointed, but not sharp instrument to dig out seal.

Inspection — Inspect cylinder bores for signs of wear or scoring. Check calipers and adaptor plates for distortion, replace as necessary.

Installation — Lightly coat seals and cylinder bore walls with suitable grease. Fit new seals to grooves in caliper bore. Insert one piston and push to bottom of caliper bore. Install dust seal and seal ring. Repeat procedures on opposite side piston.

Brakes

OPEL (Cont.)

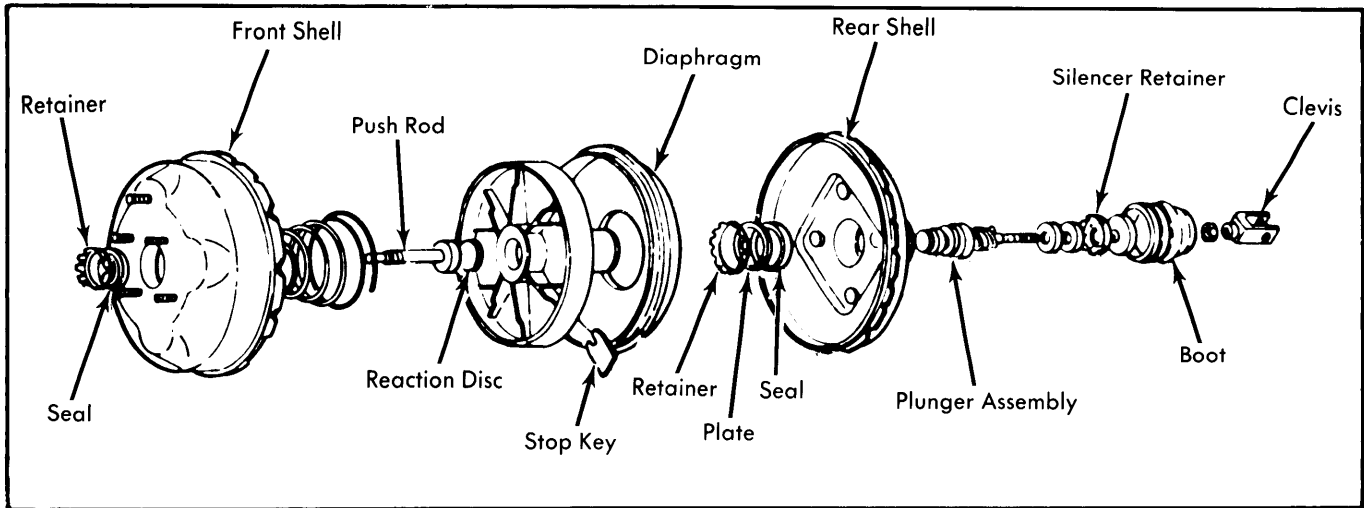

Fig. 4 Exploded View of Opel Master-Vac Power Brake Assembly

REAR WHEEL CYLINDER

Disassembly – Pull off rubber dust boots. Push from one side until pistons, cups, and return spring are forced from cylinder.

Inspection – Check cylinder bore for damage, wear or score marks. Check clearance between cylinder and bore. Clearance should not exceed .006" (.15 mm).

Reassembly – Lightly coat pistons, cups, and return spring, then reverse disassembly procedure for remaining components.

MASTER CYLINDER

Disassembly – Empty excess brake fluid from master cylinder reservoir. Separate reservoir from cylinder body. Remove brake line connectors and take out check valves, springs and retainers. Insert screwdriver and push in primary piston enough to remove secondary stop bolt and snap ring. Withdraw both piston assemblies and separate remaining components.

Inspection – Clean all parts in brake fluid and dry with compressed air. Inspect master cylinder bore for damage or wear. Measure bore diameter, value should be .875" (22.2 mm). If pistons are found defective or damaged, replace entire piston assembly. Always replace piston cup during overhaul. Master cylinder to piston clearance should be no more than .006" (.15 mm).

Reassembly – To reassemble, reverse disassembly procedure and not the following: Lightly coat all components with brake fluid before reassembling. Make sure check valve with hole is installed on front side. Insert primary piston and fit snap ring, then push in with screwdriver and install stop bolt.

POWER BRAKE UNIT

Disassembly – 1) Index mark shell halves. Remove nuts and spacer from rear shell. Remove clevis. Use tool J-22805-01 (or

equivalent) and clamp front shell in vise. Use tool J-9504-01 (or equivalent) and turn rear shell counterclockwise to remove. Take off rear shell and diaphragm retaining spring.

2) Take out diaphragm plate assembly. Remove retainer from rear shell, then take out plate and seal. Slip off diaphragm and silencer retainer, then pull out stop key. Remove plunger assembly and reaction disc. Pull push rod, retainer and seal from front shell assembly.

Inspection – Clean all components and dry with compressed air. Check all diaphragms and seals for signs of weakening; replace as necessary. Check plunger for wear; replace if worn.

Reassembly – 1) Apply silicone grease to sliding surfaces of all components. Install plate, seal, and retainer. Install plunger assembly complete with filter and silencer. Be sure poppet valve is not projected beyond retainer. Install diaphragm plate. Fit retainer and diaphragm on diaphragm plate. Put diaphragm assembly on rear shell, then fit boot and clevis.

2) Install seal assembly to front shell. Install retainer and push rod. Use holding tool J-22805-01 (or equivalent) and mount front shell in vise. Install diaphragm spring between shell halves, then force in and rotate rear shell clockwise until fully seated and aligned with index marks.

TIGHTENING SPECIFICATIONS

Application	Ft. Lbs. (mkg)
Caliper Mounting Bolts	36 (4.9)
Caliper Brake Line	11 (1.5)
Master Cylinder-to-Power Brake Unit	10 (1.4)
Master Cylinder Brake Line	12 (1.6)
Master Cylinder Brake Line Connector	87 (12.0)
Master Cylinder Stop Bolt	14 (1.9)
Wheel Cylinder Mounting Bolt	7 (.97)

OPEL (Cont.)

BRAKE SYSTEM SPECIFICATIONS				
Application	Drum Diam. In. (mm)	Wheel Cylinder Diameter		Master Cylinder
		Front In. (mm)	Rear In. (mm)	Diameter In. (mm)
All Models	8.980 (228.1)	①	.812 (20.6)	.875 (22.2)

① — Front disc brakes.

BRAKE DRUM SPECIFICATIONS				
Application	Drum Diameter In. (mm)	Original Diameter In. (mm)	Maximum Refinish Diameter In. (mm)	Discard Diameter In. (mm)
All Models	8.980 (228.1)	8.980 (228.1)	9.040 (229.6)	9.060 (230.1)