

## MERCEDES-BENZ

230  
240D  
280 Series  
300D  
450 Series  
6.9

## DESCRIPTION

Service brake system utilizes 4-wheel disc brakes, hydraulically operated by a step-type tandem, or tandem master cylinder, connected to a power unit. Step-type master cylinder can be identified by stop screw location, top center of master cylinder. Tandem master cylinder stop screw is located at bottom center of master cylinder. Brakes are manufactured by Teves or Bendix and incorporate a two or three chamber reservoir with a fluid level sensor contact built into each chamber. Warning light is activated when fluid level is low. Parking brakes are cable actuated, internal expanding shoe type, housed in rear brake rotors.

## ADJUSTMENT

## PEDAL HEIGHT

Adjust pedal height by loosening 2 hex nuts and turning stop light switch. Proper pedal free position is approximately 5.91" (150 mm) from pedal stop.

## PEDAL FREE PLAY

Adjust pedal free play to .197-.591" (5-15 mm) by loosening 2 hex nuts and turning stop light switch. Stop light switch contact button should extend .236-.315" (6-8 mm) when adjusted.

## DISC PADS

Self-adjusting, no adjustment required.

## PARKING BRAKE

Remove one wheel lug bolt at each rear wheel. Raise and support vehicle, and rotate wheels until lug bolt hole is positioned over parking brake adjuster (approximately 45° in upward and forward direction from wheel center). Using a screwdriver

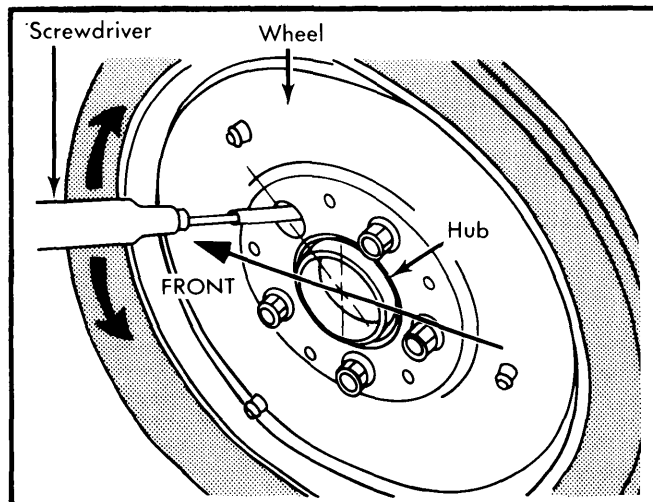

Fig. 1 Fitting Parking Brake Adjuster Tool Into Adjusting Mechanism

inserted through lug bolt hole, turn adjuster until wheel cannot be turned by hand. Back off adjuster until wheel can be turned by hand without restriction.

## HYDRAULIC SYSTEM BLEEDING

Beginning with cylinder farthest from master cylinder, attach one end of bleeder tube to bleeder screw, and submerge opposite end in a jar half full of clean brake fluid. Pump brake pedal several times, and with pedal at bottom of stroke, open bleeder screw. Close bleeder screw when fluid stops flowing from tube, then release pressure on brake pedal. Repeat procedure until fluid flowing from tube shows no sign of air.

## REMOVAL &amp; INSTALLATION

## DISC PADS

**Removal** — Raise vehicle, support with safety stands and remove wheels. If equipped, remove shaft cover plate from caliper. Drive out retaining pins toward inside of vehicle and remove cross spring. Loosen bleed fitting and using suitable extractor tool, remove disc pads from caliper assembly.

**NOTE** — All bolts are self-locking, hex-head and should be used once only.

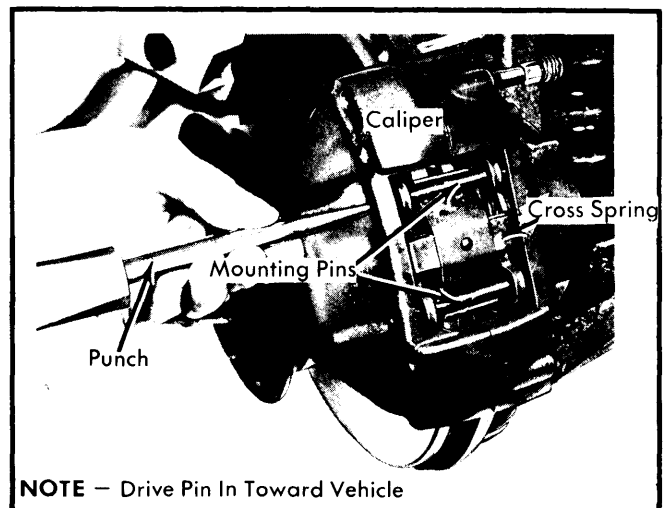

Fig. 2 Knocking Out Disc Pad Mounting Pins On Teves Model Brakes

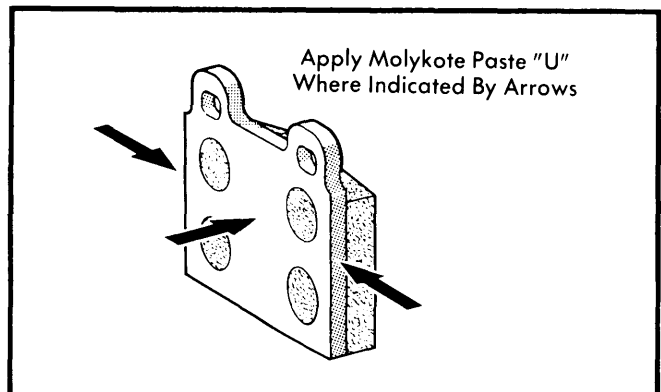

Fig. 3 Typical Mercedes-Benz Disc Brake Pad Illustration Shows Molykote Application Points

## MERCEDES-BENZ (Cont.)

**Installation** — Using a cylinder brush, clean disc pad guide surface in caliper. Siphon sufficient fluid from master cylinder reservoir to prevent overflowing, then press pistons to bottom of bores. Install disc pads, cross spring, retaining pins and cover plate (if equipped). After installation, depress brake pedal several times to position pads against rotor.

### BRAKE CALIPER

**Removal** — Raise and support vehicle, and remove wheel. Disconnect brake lines at caliper assembly, and plug lines to prevent entry of foreign matter. Remove caliper attaching bolts, and remove caliper assembly from vehicle.

**Installation** — Reverse removal procedure ensuring that calipers are replaced in matched pairs from either manufacturer. Tighten all nuts and bolts and bleed hydraulic system.

### BRAKE ROTOR

**Removal & Installation (Front)** — With caliper assembly removed, remove hub grease cap. Remove contact spring for radio shielding, loosen socket screw on clamping nut on wheel spindle, remove clamping nut and washer, then remove wheel hub and rotor assembly. Remove Allen head bolts securing rotor to hub and remove rotor. To install, reverse removal procedure, tighten all bolts and fittings evenly, and bleed hydraulic system if necessary. Adjust front wheel bearing. See *Wheel Bearing Adjustment* in **WHEEL ALIGNMENT** Section.

**Removal & Installation (Rear)** — Remove rear wheel and caliper assembly, then pull rotor out from axle shaft flange. To install, reverse removal procedure, tighten all bolts and fittings evenly, and bleed hydraulic system if necessary.

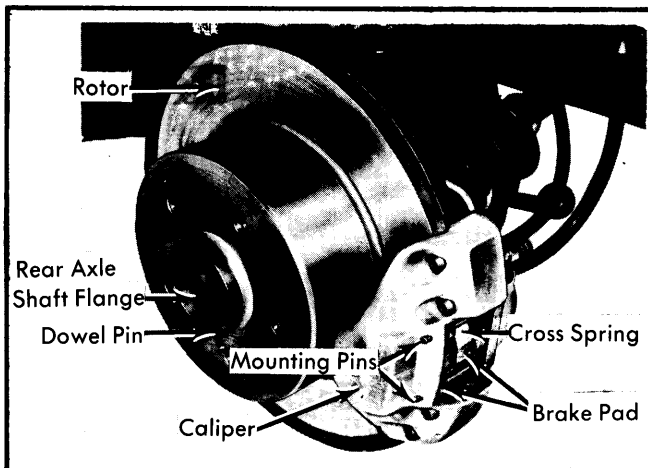

Fig. 4 Assembled View of Rear Hub and Caliper

### MASTER CYLINDER

**Removal** — Drain master cylinder of brake fluid. Disconnect and plug brake lines, disconnect electrical wires. Remove bolts securing master cylinder to power booster and remove master cylinder.

**Installation** — Reverse removal procedure and note the following: Always replace rubber "O" ring seal between master cylinder and power unit. Bleed hydraulic system and check complete system for fluid leaks.

### POWER BRAKE UNIT

**Removal** — Drain master cylinder brake fluid, and remove master cylinder from vehicle. Disconnect vacuum line at power booster, and disconnect push rod at brake pedal. Remove power brake unit attaching hardware, and remove assembly from vehicle.

**Installation** — To install, reverse removal procedure, tighten all nuts and bolts, and bleed hydraulic system.

## OVERHAUL

### BRAKE CALIPER

**Disassembly** — With caliper removed from vehicle and disc pads removed from caliper, remove dust cap from piston housing. Hold one piston in place using a suitable clamp, then apply compressed air to fluid inlet and remove opposite piston. Remove piston seal from groove of cylinder bore. Remove remaining piston and seal in same manner. **CAUTION** — Do not separate caliper halves.

**Cleaning & Inspection** — Remove deposits on piston with a soft brass wire brush. **NOTE** — Do not use polishing or emery cloth on pistons, as they could damage chrome plated surface. Check cylinder bore of caliper for wear or damage. Small rust spots in bore can be removed with polishing cloth and heavier rust spots in front of piston seal groove with fine emery paper.

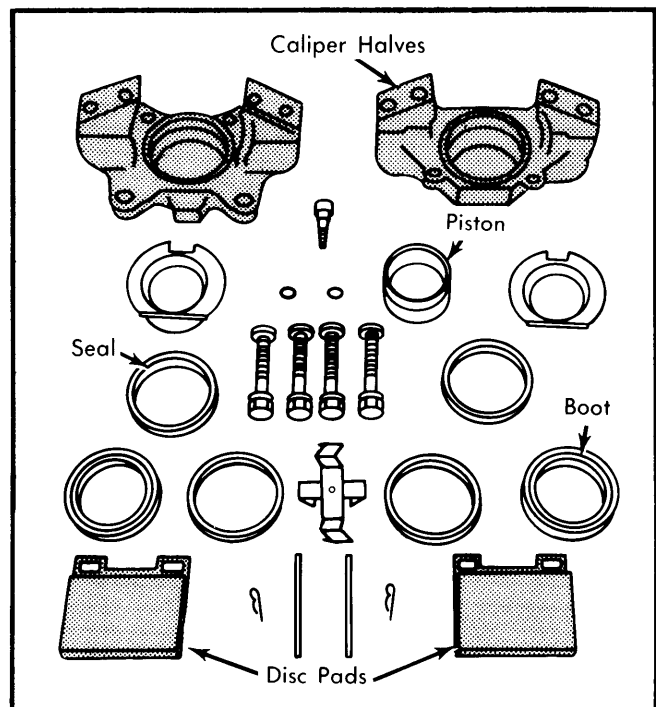

Fig. 5 Disassembled View of Typical Mercedes-Benz Brake Caliper

**Reassembly** — Coat piston and caliper bore with ATE brake cylinder paste (or equivalent), install piston seal into groove of bore, then install piston. **NOTE** — Install piston so that elevation on piston is facing downward. Install dust cap. Install heat shield into piston with recess in shield fitting into elevation of piston. **NOTE** — Elevation should project at least .004" (.1 mm) above shield.

## MERCEDES-BENZ (Cont.)

### MASTER CYLINDER

**CAUTION** — Bendix master cylinder, spray painted blue, cannot be repaired.

**Disassembly (Tandem and Step Tandem)** — Remove reservoir, push piston in with screwdriver, then remove stop screw and "O" ring. Remove lock ring from housing, then remove piston, stop washer, 2 vacuum seals and intermediate ring. Remove intermediate piston by rapping lightly with a wooden board.

**NOTE** — Teves reservoir only, remove cap, end covers, strainer, splash guard, "O" rings and contact inserts. Bendix model, remove strainer from cover. DO NOT remove contact inserts. All models, master cylinder diameter should be .937" (23.81 mm).

**Inspection** — Clean all parts with alcohol or brake fluid. Check bore in housing and piston for scoring and rust. Small rust spots in housing may be removed with polishing cloth. Scored or badly rusted parts cannot be repaired, replace complete master cylinder.

**Reassembly** — Reverse disassembly procedure and bleed hydraulic system.

### TIGHTENING SPECIFICATIONS

Application	Ft. Lbs. (mkg)
Front Caliper Mounting Bolts.....	83 (11.5)
Rear Caliper Mounting Bolts.....	65 (9)
Master Cylinder Attaching Bolts.....	9-10 (1.2-1.4)
Rotor-to-Wheel Hub Bolts.....	83 (11.5)
Hydraulic Line Fittings.....	11 (1.5)

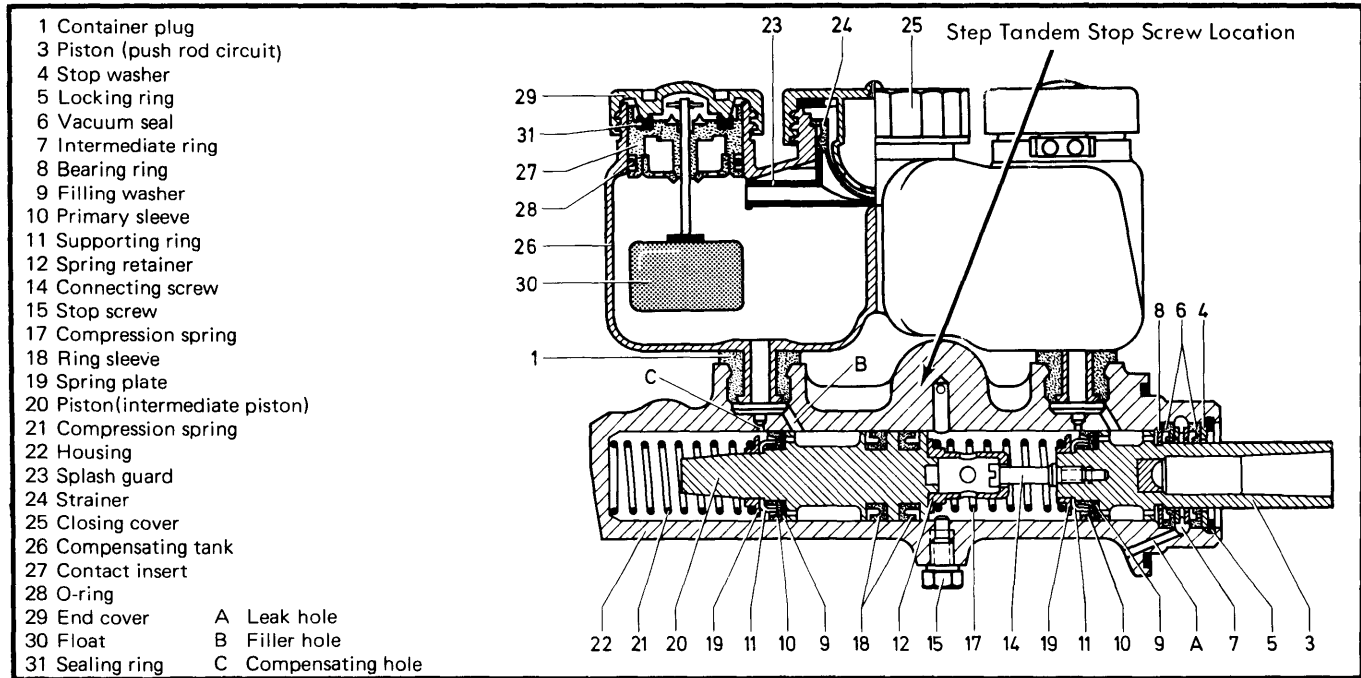

Fig. 6 Sectional View of Late Model Mercedes-Benz Tandem Master Cylinder

### DISC BRAKE ROTOR SPECIFICATIONS

Application	Disc Diameter In. (mm)	Lateral Runout In. (mm)	Parallelism In. (mm)	Original Thickness In. (mm)	Minimum Refinish Thickness In. (mm)	Discard Thickness In. (mm)
240D, 300D, 230 280E, 280CE, 300CD Front	10.98 (279)	.0047 (.12)	.0008 (.02)	.496 (10)	.457 (9.4)	.435 (9.02)
Rear	10.98 (279)	.0047 (.12)	.0008 (.02)	.394 (10)	.370 (9.4)	.355 (9.02)
280SE, 450SEL, 6.9 450SC, 450SLC Front	10.94 (278)	.0047 (.12)	.0004 (.01)	.866 (22)	.827 (21)	.737 (20)
Rear	10.98 (279)	.0047 (.12)	.0004 (.01)	.394 (10)	.370 (9.4)	.355 (9.02)