

## HONDA

Civic  
Civic CVCC  
Accord

### DESCRIPTION

Brake system is hydraulically actuated, using a tandem master cylinder and a power brake booster unit. On Civic models and Civic CVCC sedan models, front brakes are dual piston floating caliper type. CVCC station wagon models and Accord models utilize single piston front disc brakes. All models use leading-trailing shoe/drum type rear brakes actuated by a dual piston wheel cylinder. Parking brake is cable and lever operated, actuating shoes of rear brake assemblies. All models use proportioning valve arrangements to differentiate pressure to rear wheels. All vehicles are equipped with a brake warning light that indicates hydraulic pressure loss and when parking brake is engaged.

### ADJUSTMENT

#### PEDAL FREE PLAY

Brake pedal free play is distance pedal travels from pedal stop (brake light switch) before push rod contacts vacuum booster. Adjust pedal free play to .039-.196" (1-5 mm), measured at pedal pad, by adjusting brake light switch.

#### FRONT DISC BRAKE PADS

Front disc brakes are self-adjusting, therefore, no adjustment in service is required.

#### REAR BRAKE SHOES

With parking brake released, depress brake pedal two or three times and release. Turn adjuster on backing plate clockwise until wheel no longer turns. Back off adjuster two clicks and ensure wheel rotates freely. If brakes are dragging, back off one additional click.

#### PARKING BRAKE

With rear brakes adjusted, pull parking brake lever to check operation. Rear wheels should be locked when lever is pulled one to five notches on ratchet. Adjustment is made at equalizer located between rear lower control arms.

#### HYDRAULIC SYSTEM BLEEDING

- 1) Attach a bleed tube to cylinder bleed screw and immerse opposite end of tube in a container partially filled with brake fluid.
- 2) Pump pedal several times. Hold steady pressure on pedal. Open bleed screw. Allow air to escape into container. Close bleed screw with pedal still depressed. Let pedal return unassisted.
- 3) Repeat procedure on remaining brake cylinders until all air is bled from system. Bleeding sequence is left front, right rear, right front, right rear.

### REMOVAL & INSTALLATION

#### FRONT DISC BRAKE PADS

**Removal; Civic & CVCC Sedan** — Raise and support front of vehicle; remove front wheels. Remove pin retaining clip, retaining pins and springs. Note that springs are not interchangeable, reference mark for reassembly. Remove disc pads and shims from one side. DO NOT remove pads from both sides at one time.

**Installation** — Clean exposed portions of caliper pistons and cavity. Manually seat caliper pistons in cylinders. Check disc pad thickness. If less than .240" (6.1 mm), replace with new pads. If thickness variation between disc pads sets exceeds .079" (2 mm), replace pads. Install pads, shims (index arrow facing up), pad springs, and retaining pins. Secure retaining pin with clips.

**Removal; CVCC Station Wagon** — Raise and support front of vehicle; remove front wheels. Remove pad shield. Take off pad retainer clips. Drive out retaining pins and pull pads from caliper housing.

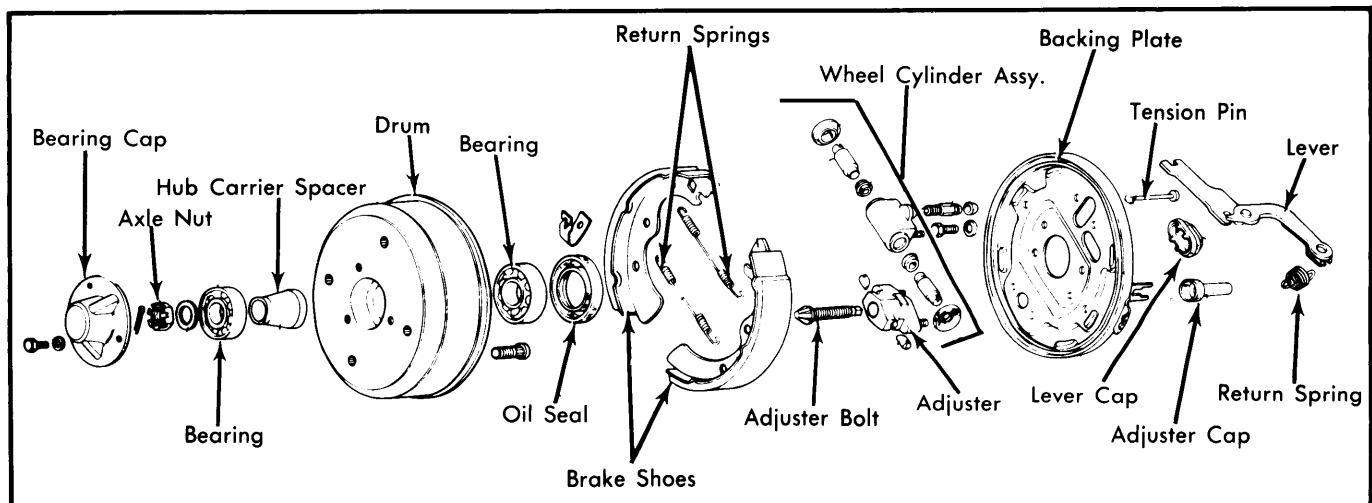

Fig. 1 Honda Rear Drum Brake Assembly — Civic Shown — Others Similar

## HONDA (Cont.)

**Installation** — To install, reverse removal procedure and note: Make sure all rust has been removed from brake pad retaining pins. Inspect brake pad thickness. If pads are worn so that thickness is less than .300" (6.5 mm) or if thickness variation between disc pad sets exceeds .079" (2 mm), replace pads.

**Removal; Accord** — Raise and support front of vehicle. Remove wheel. Using a pair of pliers, remove spring clips. Pull off top and bottom side plates. Lift off caliper and suspend out of way. Remove disc pad anti-rattle clip and slide off pads.

**Installation** — To install, reverse removal procedure and note: Clean exposed areas of caliper. Check disc pad thickness. If pad thickness is less than .236" (6 mm) or if thickness variation between disc pad sets exceeds .079" (2 mm), pads must be replaced.

## FRONT DISC BRAKE CALIPER

**Removal; Civic & CVCC Sedan** — Raise and support front of vehicle. Remove front wheels. Disconnect hydraulic line at caliper, remove bolts retaining caliper to steering knuckle. Lift off caliper assembly.

**Installation** — Reverse removal procedure and bleed hydraulic system.

**Removal; CVCC Station Wagon** — Raise vehicle and remove disc pads as previously outlined. Disconnect and plug brake fluid line. Remove caliper mounting bolt and lift off vehicle.

**Installation** — To install, reverse removal procedure and bleed brake system.

**Removal; Accord** — Raise and suitably support front of vehicle. Remove wheel. Disconnect and plug brake lines. Remove spring pins and caliper side plate covers. Pull off caliper cylinder. Mounting bracket can now be removed if necessary.

**Installation** — To install, reverse removal procedure and bleed brake system.

## DISC BRAKE ROTOR

**Removal** — 1) Raise and support front of vehicle; remove front wheel. Before continuing removal procedure, check rotor runout and compare to specifications. Remove spindle nut and caliper assembly.

**NOTE** — Do not allow caliper to hang by brake line.

2) Using a slide hammer with hub puller attachment, remove hub and rotor assembly. Index mark hub and rotor, then remove bolts and separate.

**NOTE** — Since removing hub and rotor assembly involves use of a slide hammer and subjects wheel bearings to severe loads, it is suggested that both inner and outer wheel bearings be replaced each time hub and rotor assembly is removed.

**Installation** — Reverse removal procedure, tighten rotor-to-hub bolts evenly, and bleed hydraulic system if necessary.

## REAR BRAKE DRUM

**Removal** — Raise and support rear of vehicle and remove rear wheels. Remove bearing retaining cap and rear axle nut, then remove brake drum. **NOTE** — If drum is difficult to remove, use a slide hammer with a hub puller attachment.

**Installation** — Reverse removal procedure and tighten axle nut.

## REAR BRAKE SHOES

**NOTE** — All models have same basic brake system design; however, there may be some minor differences.

**Removal** — With rear brake drum removed, remove tension pin clips and brake shoe return springs, and remove brake shoes.

**Installation** — 1) Reverse removal procedure and note the following: Upper and lower return springs are not interchangeable.

2) On Civic models, upper spring is identified by tight bends on each end and is designed so spring coils are located on outside of shoes when installed. Lower springs are designed so spring coils ride inside of shoes.

3) On all other models, 2 upper return springs are used to support shoes.

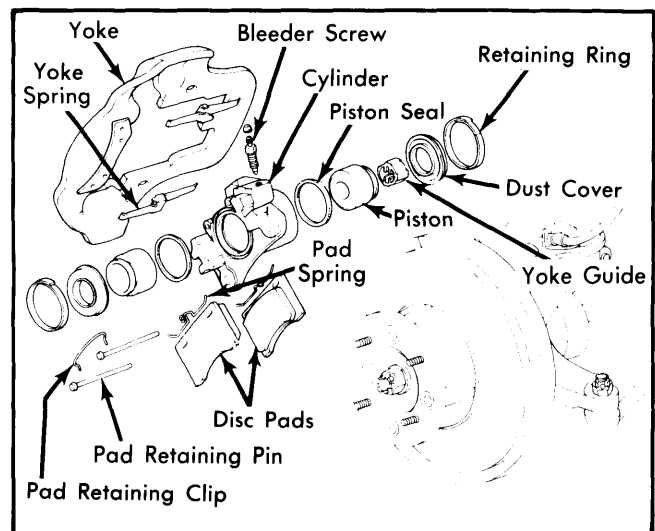

Fig. 2 Disc Brake Assembly for Civic and CVCC Sedan

## REAR BRAKE WHEEL CYLINDER

**Removal** — With rear brake drum and brake shoes removed, disconnect hydraulic line from wheel cylinder at rear of backing plate. Remove retaining nuts and wheel cylinder assembly.

**Installation** — Reverse removal procedure, tighten retaining nuts, and bleed hydraulic system.

## HONDA (Cont.)

### MASTER CYLINDER

**Removal** — Disconnect hydraulic lines at master cylinder, remove retaining nuts, and remove master cylinder from power brake unit.

**Installation** — Reverse removal procedure and bleed hydraulic system.

### POWER BRAKE UNIT

**Removal** — Disconnect vacuum hose at power brake unit, and hydraulic lines at master cylinder. Remove clevis pin retaining power brake unit push rod to brake pedal, and bolts attaching power unit to firewall, then remove power brake unit and master cylinder as an assembly.

**Installation** — Reverse removal procedure, tighten all nuts and bolts, and bleed hydraulic system.

## OVERHAUL

### DISC BRAKE CALIPER

**Disassembly; Civic & CVCC Sedan** — Holding caliper assembly in hands, press caliper down to compress piston. Keep pistons compressed and lift up on caliper removing yoke. Remove yoke return springs. Using light air pressure, force out pistons. Remove seals from cylinder bore grooves being careful not to scratch bore. **NOTE** — Calipers are marked left "L" and right "R".

**Inspection** — Clean and thoroughly dry all parts. Inspect all components for wear or damage. Check piston and cylinder bore scratching. Do not reuse inner seals, replace them.

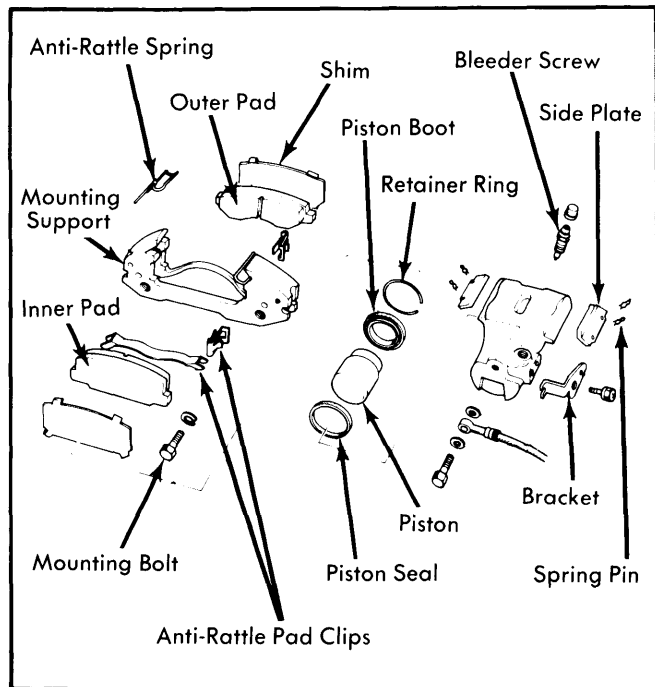

**Fig. 3 Exploded View of Accord Disc Brake Assembly**

**Reassembly** — 1) Install piston seals into grooves in cylinder. Lubricate pistons with brake fluid and install into cylinder. Install yoke guide into inboard piston. Hold yoke with retaining pin bracket facing up, and install yoke springs so long thin portion of spring is on upper side.

2) Hold yoke with retaining pin bracket facing up and to left. Place cylinder so that inlet port is facing up and to right. Slide yoke over cylinder. When yoke springs contact cylinder sliding surface, push down firmly and slide yoke to left until securely engaged with cylinder. Install disc pads, springs, pins and retainer.

**Disassembly; CVCC Station Wagon** — Remove caliper bridge bolt and carefully separate inner caliper with piston from torque plate and outer caliper. Remove rubber bushing insert from inner caliper housing. Take out retainer ring and wiper seal. Remove snap ring and dust seal, then force from cylinder. Using a pointed, but not sharp tool, remove "O" ring seal.

**Inspection** — Clean all components in brake fluid and inspect for excessive damage or wear. Replace all rubber parts. Look inside cylinder bore for signs of scoring or rough surfaces. Check outer caliper for cracks or metal fatigue.

**Reassembly** — Reverse disassembly procedure and note: Lightly grease shafts of torque plate. Lightly lubricate all internal components with brake fluid before reassembly. Make sure "O" ring seal is not twisted in cylinder groove.

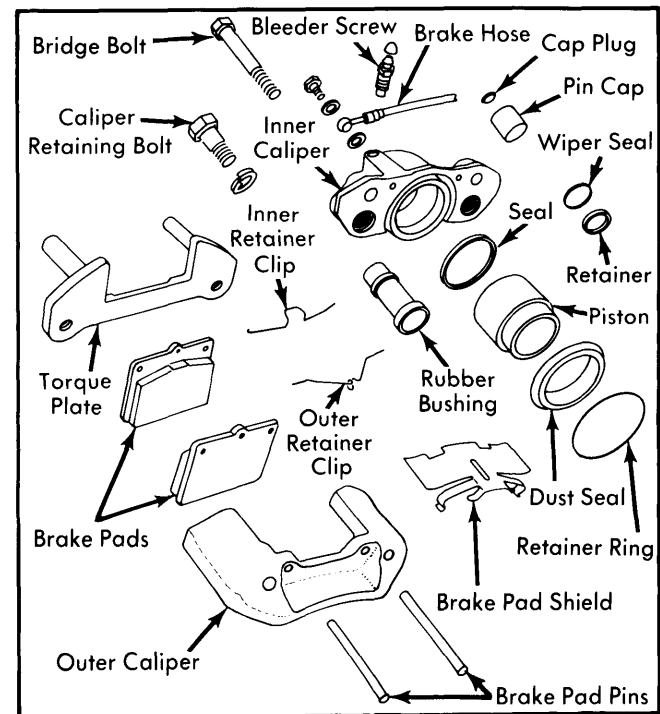

**Fig. 4 Exploded View of CVCC Station Wagon Disc Brakes**

**Disassembly; Accord** — Remove snap ring retainer and piston boot. Apply light air pressure to caliper through brake fluid inlet port. Using a pointed tool, remove piston seal.

**Inspection** — Examine cylinder piston and bore for scoring, rough spots or excessive wear. Replace all rubber components.

## HONDA (Cont.)

**Reassembly** — Reverse disassembly procedure and note: Make sure seal is properly fitted to cylinder groove.

**REAR WHEEL CYLINDER**

**Disassembly** — Remove dust seals and pistons. Remove cylinder cups from pistons. If necessary, remove bleeder screw.

**Cleaning & Inspection** — Clean and dry all parts and inspect for wear or damage; replace parts as necessary. Check cylinder bore-to-piston clearance; if clearance exceeds .005", replace piston or cylinder as necessary.

**Reassembly** — Coat cylinder walls, pistons, and cups with brake fluid and install into cylinder bore. **NOTE** — Install cups on pistons so that lips of cups face center of cylinder. Install dust covers making sure lips engage grooves on cylinder body.

**MASTER CYLINDER**

**NOTE** — Accord and Civic models have some minor external modifications that make physical appearance different. Overhaul Procedures are same as for earlier models.

**Disassembly** — Remove reservoir caps and floats and drain brake fluid. Loosen retaining clamps and remove reservoirs. Remove primary piston stop bolt, retaining clip, and washer, then remove primary piston. Hold a finger over stop bolt hole, apply compressed air to secondary outlet, and remove secondary piston. Remove two union caps, washers, check valves, and springs.

**Cleaning & Inspection** — Clean and dry all parts and inspect for wear or damage. Check clearance between master cylinder bore and pistons; if greater than .005", replace pistons or cylinder assembly as required. Check for clogged orifices in pistons and cylinder. **NOTE** — Manufacturer recommends replacing piston cups and check valves whenever cylinder has been disassembled.

**Reassembly** — Reverse disassembly procedure and note the following: Coat all parts with brake fluid when assembling. When installing pistons, push in while rotating to prevent damaging cups.

**POWER BOOSTER UNIT**

**Disassembly** — 1) Separate master cylinder from booster assembly, but leave retaining plate attached to booster shell. Remove spring clip and booster shell retaining tab, then separate push rod from master cylinder.

2) Place booster assembly in vise. Index-mark shell halves and separate halves with suitable tool. Turn tool clockwise, noting that shell is spring-loaded. Take booster from vise and remove master retaining plate, check valve, seal retainer and seal.

3) Remove booster push rod and boot. Separate housing from diaphragm and piston. Take off seal retainer, seal (note position), and bushing. Disengage snap ring, spring, and seat, then pull out diaphragm.

4) Remove retaining cover, push rod actuator, retaining plate, center seat, and spring washer (note position). Push piston from diaphragm plate. Extract "O" ring from inside piston. Remove filter retaining clip, then take off filter, push plate, spring, and poppet valve.

**Inspection** — Thoroughly wash all components in alcohol and blow dry with compressed air. Check all parts for wear and carefully look at booster plate and piston for scratches.

**Reassembly** — Reverse disassembly and note the following: Coat lip of seal with silicon before installing into booster housing. Be sure bushing fully seats into position. Make sure piston "O" ring has a perfect fit. Install reaction plates with curved side facing up. Lightly coat piston with silicon before installing in booster housing. After fitting master cylinder push rod, measure distance between booster shell and end of push rod. Clearance should be .024" (.6 mm).

**PROPORTIONING VALVES**

**NOTE** — Some models use two proportioning valves. Proportioning valves are NOT to be overhauled; if determined defective, replace.

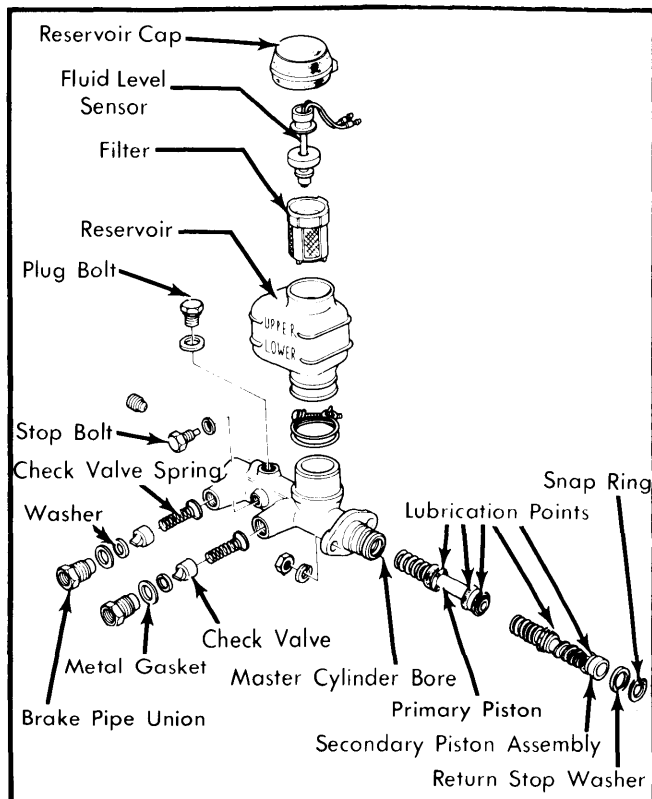
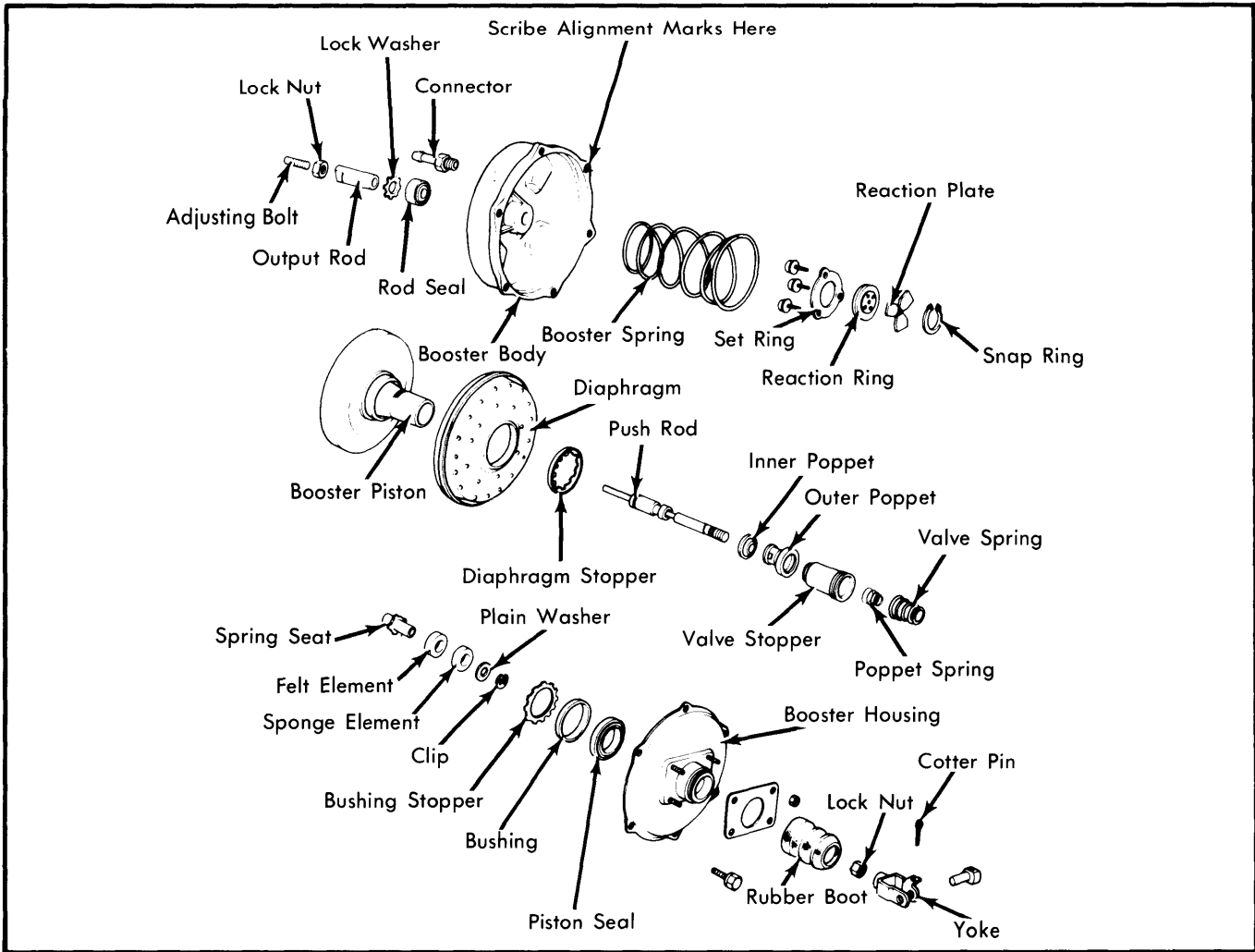

Fig. 5 Exploded View of Master Cylinder

**TIGHTENING SPECIFICATIONS**

Application	Ft. Lbs. (mkg)
Caliper Mounting Bolts	
Civic & CVCC Sedan.....	29 (4.0)
CVCC Wagon.....	63 (8.5)
Accord.....	58-66 (8.0-9.0)
Rear Axle Nut	
Except Accord.....	83 (11.5)
Master Cylinder Nuts.....	9 (1.2)

## HONDA (Cont.)



**Fig. 6 Exploded View of Honda Accord Power Brake Unit**

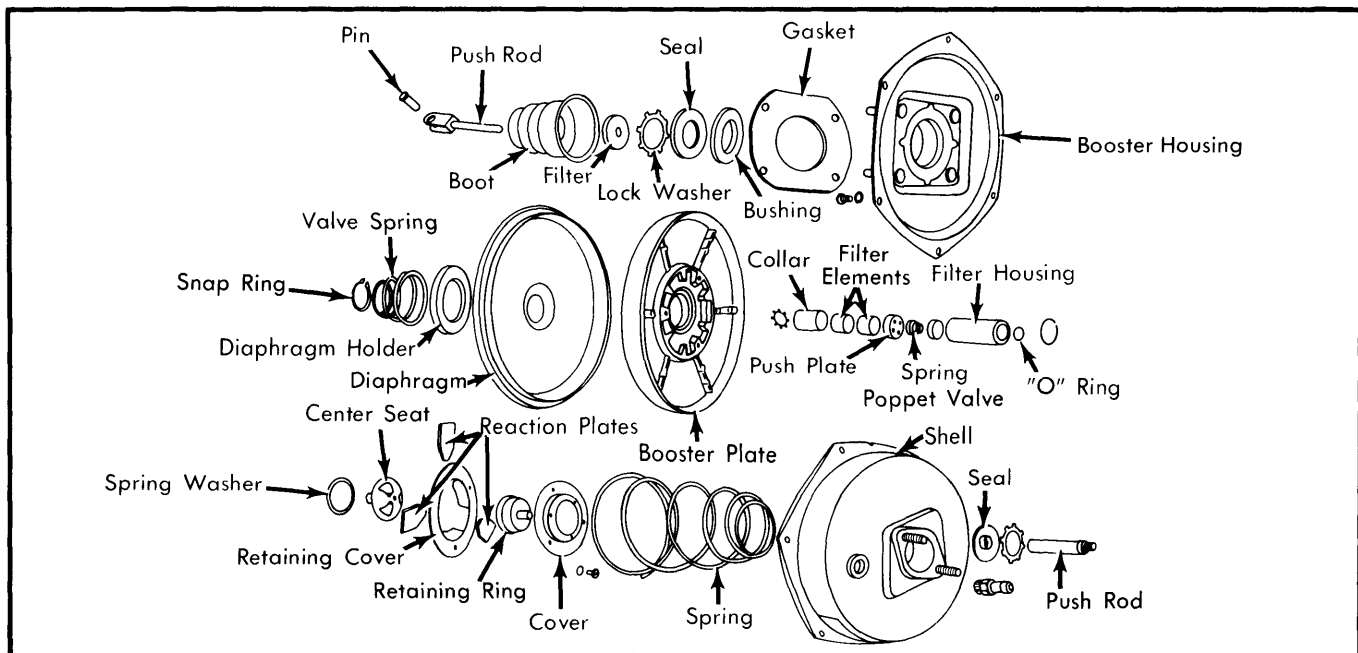

**Fig. 7 Exploded View of Civic CVCC Power Booster Unit**

# Brakes

## HONDA (Cont.)

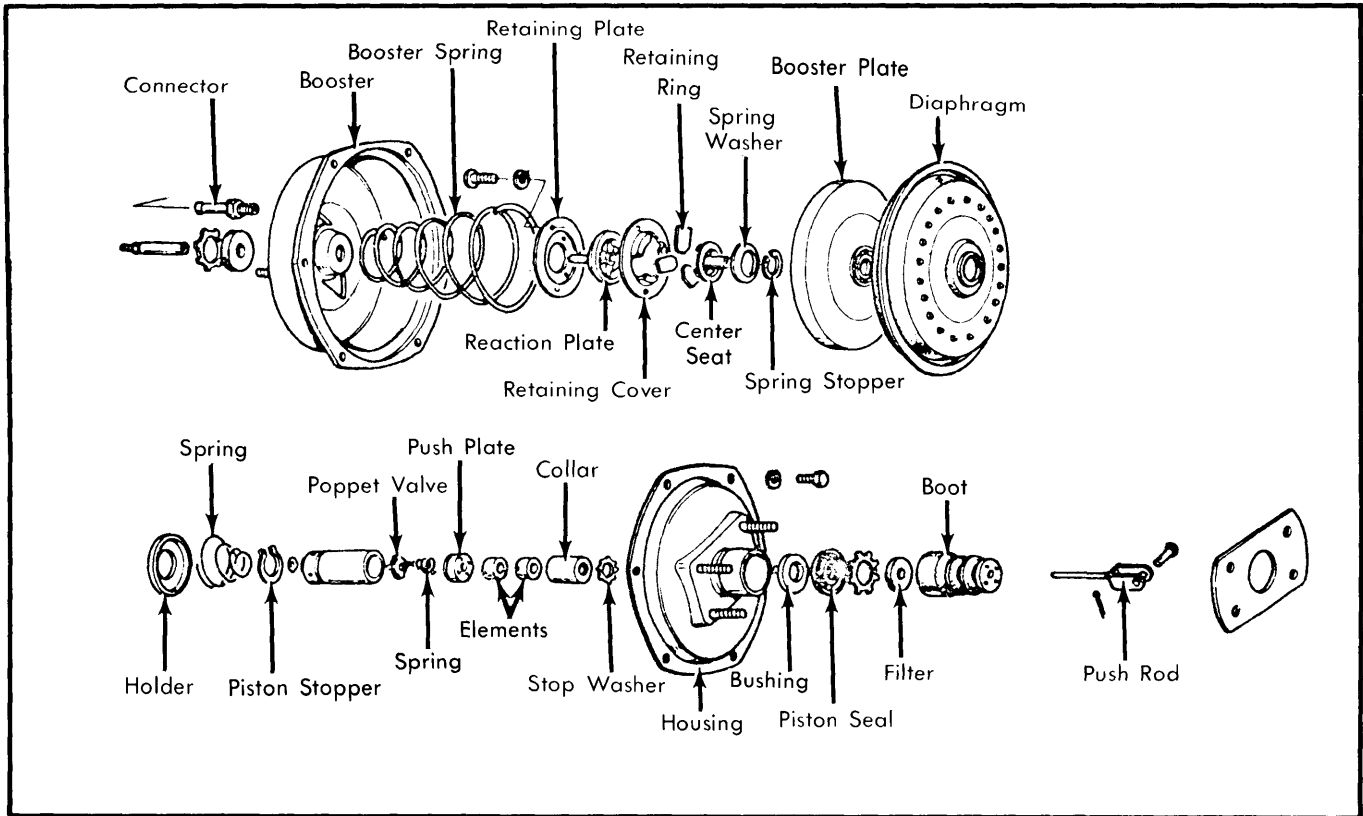

Fig. 8 Exploded View of Honda Civic Power Booster Unit

### DISC BRAKE ROTOR SPECIFICATIONS

Application	Disc Diameter In. (mm)	Lateral Runout In. (mm)	Parallelism In. (mm)	Original Thickness In. (mm)	Minimum Refinish Thickness In. (mm)	Discard Thickness In. (mm)
Civic	.....	.006 (1.5)	.003 (.07)	.378 (9.6)	.354 (9.0)	.343 (8.7)
CVCC Sedan	.....	.006 (.15)	.003 (.07)	.378 (9.6)	.354 (9.0)	.343 (8.7)
Sta. Wgn.	.....	.006 (.15)	.003 (.07)	.473 (12.0)	.449 (11.4)	.437 (11.1)
Accord	.....	.006 (.15)	⓪	.473 (12.0)	.449 (11.4)	.437 (11.1)

⓪ - Max. difference between measurements .006" (.15 mm).

### BRAKE DRUM SPECIFICATIONS

Application	Drum Diameter In. (mm)	Original Diameter In. (mm)	Maximum Refinish Diameter In. (mm)	Discard Diameter In. (mm)
Civic	7.08 (180)	7.08 (180)	7.13 (181)	7.15 (181.5)
CVCC Sedan	7.08 (180)	7.08 (180)	7.13 (181)	7.15 (181.5)
CVCC St.Wgn	7.87 (200)	7.87 (200)	7.91 (201)	7.93 (201.5)
Accord	7.08 (180)	7.01 (180)	7.13 (181)	7.15 (181.5)