

## DATSUN F10, 200SX, B210

F10  
200SX  
B210

## DESCRIPTION

Brake system is hydraulically operated, utilizing a tandem master cylinder and a Master-Vac power brake unit. Front disc brakes consist of rotors attached to wheel hubs, and single cylinder, dual-piston, floating-calipers attached to steering knuckles. Rear brakes are leading-trailing shoe/drum type, using a single piston sliding wheel cylinder. Parking brake is cable actuated, operating wheel cylinders of rear brake assemblies.

## ADJUSTMENT

## PEDAL HEIGHT &amp; FREE PLAY

**F10** — Adjust pedal height to 6.8-7.0" (172-178 mm) by turning nut on master cylinder push rod. Adjust stop light switch so pedal just touches end of stop light switch; tighten lock nut. **NOTE** — Brake pedal should be checked for travel and smooth operation. Travel should be 5-5.25" (127-133 mm).

**200SX** — Adjust pedal height to about 6.9" (175.5 mm) using stop light switch. Lock switch in place with retaining nut. After pedal height is adjusted, loosen push rod lock nut and adjust pedal free play to .039-.118" ( 1-3 mm).

**B210** — Adjust pedal height to specifications by moving stop lamp switch. Pedal height should be 6.14" (156 mm) on vehicles equipped with manual transmission and 6.22" (158 mm) on vehicles with automatic transmission. After pedal height is adjusted, loosen push rod lock nut and adjust pedal free play to .039-.197" (1-5 mm).

## FRONT DISC BRAKE PADS

Front disc brakes are self-adjusting, therefore, no adjustment in service is required.

## REAR BRAKE SHOES

**F10** — Raise and support vehicle. Pump brake pedal several times to center brake shoes. Using a screwdriver, turn adjuster star until considerable drag is evident. Back off adjuster five or six notches and make sure drum rotates freely.

**200SX** — No adjustment required.

**B210** — Raise and support vehicle. Using a suitable brake adjusting tool, tighten adjuster eccentric clockwise until brake shoe contacts drum. Return adjuster eccentric until shoe is slightly separated from drum. Check operation by turning drum and applying brakes; if shoe interferes with drum rotation, readjust.

## PARKING BRAKE

With rear brakes properly adjusted, adjust parking brake cable turnbuckle until rear brakes are locked when parking brake lever is pulled to sixth or seventh ratchet stop. Release parking brake lever and ensure rear wheels turn freely and that all parts are returned to their original position.

## COMBINATION VALVE

**Function Test, All Models** — Accelerate engine to 30 mph and rapidly apply brakes. If rear wheels lock before front wheels, malfunction of combination valve assembly (200SX & B210), or of separate proportioning valve (F10) is indicated.

## HYDRAULIC SYSTEM BLEEDING

Attach a bleed tube to bleeder screw and immerse opposite end of tube in a container partially filled with brake fluid. Pump brake pedal two or three times, keep pedal fully depressed, open bleeder screw and exhaust air, close bleeder screw, and return brake pedal. Repeat operation until air bubbles are no longer seen in discharged fluid. Repeat procedure on remaining brake lines. Bleed rear wheels first, then front wheels.

## REMOVAL &amp; INSTALLATION

## FRONT DISC BRAKE PADS

**Removal** — Raise front of vehicle and support in place, then remove front wheels. Remove clips from retaining pins and pull out pins, coil springs and pad springs. Remove pads from caliper assembly using a suitable pair of pliers.

**Inspection** — With friction pads removed, measure their thickness. Replace any pad that is worn to less than .063" (1.6 mm) in thickness (not including metal backing plate). It is recommended that friction pads be replaced as a set to prevent any possibility of uneven braking.

**NOTE** — Replace all pads at same time.

**Installation** — Clean and apply P.B.C. grease (or equivalent) on yoke guide groove of cylinder body, sliding contact portions of yoke and end surface of piston. Loosen bleeder screw and push outer piston in cylinder until end surface of piston coincides with end surface of retaining ring on boot. Install inner brake pad. Push inner piston in cylinder by pulling on yoke, then install outer brake pad. After installing pads, depress brake pedal several times to seat pads.

## FRONT DISC BRAKE CALIPER

**Removal** — Raise vehicle and suitably support on safety stands; remove tire and wheel. Remove brake friction pads as previously described. Disconnect brake line from wheel cylinder. To ease removal of caliper, remove strut assembly and knuckle arm mounting bolt. Withdraw caliper mounting bolt and separate it from strut assembly.

## DATSUN F10, 200SX, B210 (Cont.)

**Installation** — To install brake caliper assembly, reverse removal procedures, noting the following: Bleed hydraulic system.

### FRONT DISC BRAKE ROTOR

**Removal (200SX & B210)** — With caliper removed, remove hub dust cap, cotter pin and nut. Remove hub and rotor assembly with wheel bearing and washer in place. Remove bolts attaching rotor to wheel hub and separate rotor from hub.

**Installation** — Reverse removal procedure, tighten rotor-to-hub bolts securely, and adjust wheel bearings. See *Wheel Bearing Adjustment* in *WHEEL ALIGNMENT* Section. Use a dial indicator to measure rotor runout. Resurface rotor if runout exceeds .0047" (.12 mm)

**Removal (F10)** — With caliper removed, remove stub axle cotter pin, washer and mounting nut. Using a puller, withdraw stub axle and brake rotor as an assembly. Rotor can now be separated from stub axle.

**Installation** — To install stub axle and rotor assembly, reverse removal procedure and tighten stub axle mounting nut to 87-145 ft. lbs. (12-20 mkg).

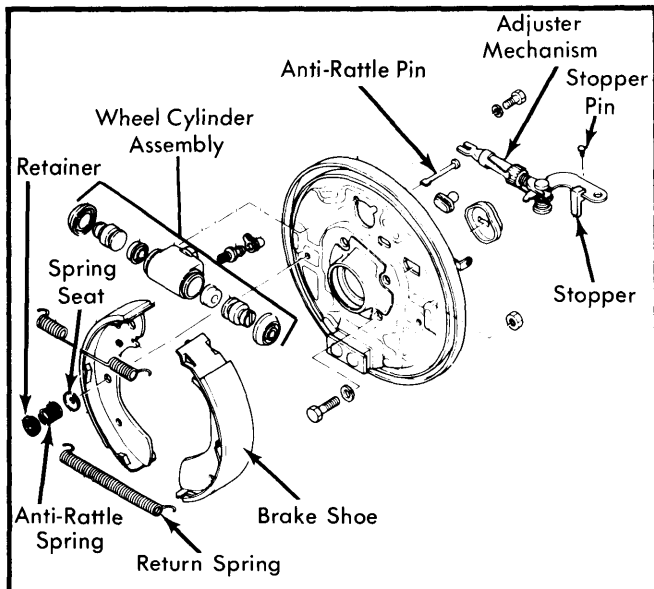

Fig. 1 Exploded View of Datsun 200SX Rear Brake Assembly

### REAR BRAKE ASSEMBLY

**Removal (Rear)** — Raise vehicle and suitably support on safety stands; remove tire and wheel. Loosen parking brake linkage at clevis pin and place out of way. Remove brake drum. Remove shoe retainer and return spring, then lift off shoe assembly. Disconnect brake line from wheel cylinder. If necessary, wheel cylinder can now be removed by taking out mounting bolt.

**Inspecting** — Inspect all brake components for damage or excessive wear and replace those found defective. Replace brake lining if it is oil soaked or lining is less than .059" (1.5mm) thick.

**Installation** — To install rear brake lining, reverse removal procedures, noting the following: Readjust shoe-to-drum clearance and, if necessary, bleed hydraulic system.

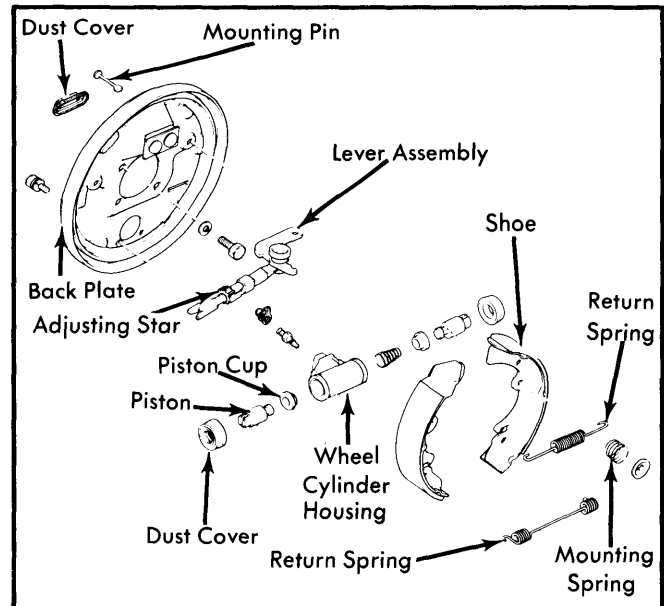

Fig. 2 Exploded View of F10 and B210 Rear Brake Assembly

### MASTER CYLINDER

**Removal** — Disconnect any electrical leads attached to cylinder reservoir. Disconnect front and rear brake lines from master cylinder outlet ports. On models equipped without power brakes, separate master cylinder push rod from pedal. Remove cylinder mounting nuts and slide unit off studs. Make sure brake fluid does not drop on paint.

**NOTE** — On F10 models, fluid reservoir can be removed attached to cylinder.

**Installation** — To install master cylinder, reverse removal procedures, noting the following: Bleed hydraulic system and check pedal height.

### POWER BRAKE UNIT

**Removal** — Disconnect power unit push rod from brake pedal by removing clevis pin. Disconnect hydraulic lines from master cylinder and vacuum line from power unit, remove master cylinder attaching nuts, and remove master cylinder. Remove nuts attaching power unit to firewall, and remove power unit from engine compartment.

**Installation** — Reverse removal procedure, adjust brake pedal height, and bleed hydraulic system.

**Check Valve Removal** — Check valve is located in vacuum line between intake manifold and power unit on firewall. To remove, disconnect retaining clip from firewall, remove hose clamps, separate hoses from valve, and remove check valve. To install, reverse removal procedure.

## OVERHAUL

### FRONT DISC BRAKE CALIPER

**Disassembly** — With caliper removed, drain brake fluid and remove bleeder screw. Push both pistons into cylinder bore, then place yoke in a vise and tap the top of yoke lightly with a

## DATSUN F10, 200SX, B210 (Cont.)

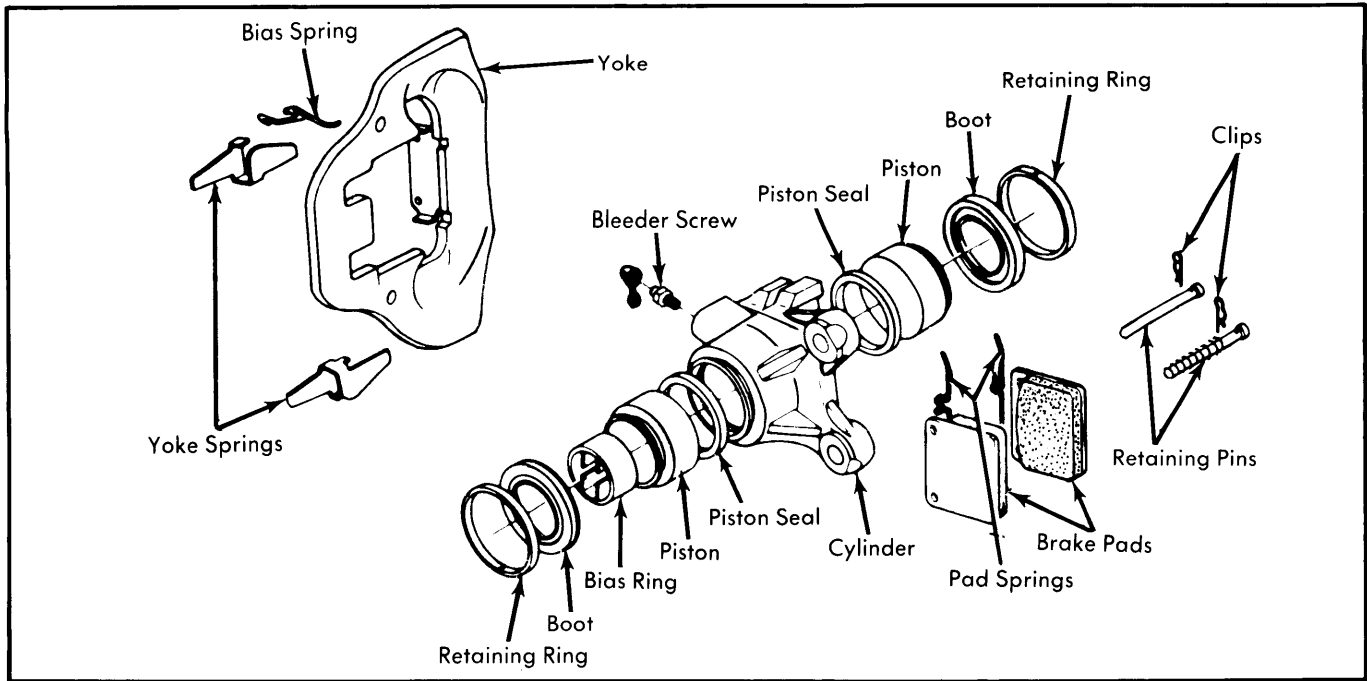
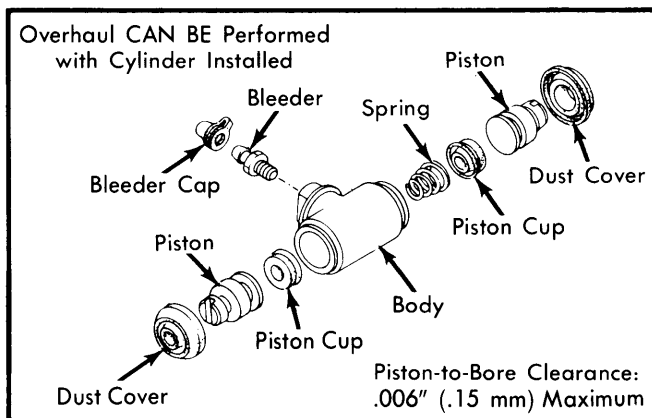

**Fig. 3 Exploded View of Front Disc Brake Caliper**

hammer to separate cylinder from yoke. Remove bias ring from outer piston, then remove retaining rings and boots. Push both pistons out in one direction. Remove piston seals from cylinder and yoke spring from yoke.

**Inspecting** — Thoroughly clean all internal parts and check each component for excessive wear or damage. If caliper bore is damaged or excessively rusted, it must be replaced. If, however, slight imperfections are evident, honing will eliminate them. It is recommended to replace all seals when overhauling.

**Reassembly** — Before assembling components, lightly coat with suitable brake grease. Insert bias ring into piston so round portion of ring fits to bottom of piston. Insert piston into cylinder. Do not fully seat piston. Install dust boot and retaining ring. Install yoke bias ring so it coincides with yoke groove of cylinder. Fit bias spring to yoke so bias spring faces bleeder side of cylinder. With yoke spring inserted in cylinder groove, properly align position of bias spring so groove of spring aligns with yoke. Assemble body-to-yoke, tapping lightly if necessary.



**Fig. 4 Exploded View of Datsun Wheel Cylinder Used on F10, 200SX and B210 Models**

### MASTER CYLINDER

**NOTE** — On F10 models, separate reservoir tank assembly.

**Disassembly** — Remove master cylinder reservoir caps and filters and drain brake fluid. Using a screwdriver, pry off stopper ring. Remove stopper screw and pull out primary piston assembly, spring and secondary piston assembly. Remove plugs and pull out front and rear check valves.

**NOTE** — On all except F10 models, do not remove reservoir tanks. If tanks are removed for any reason, discard and install new ones.

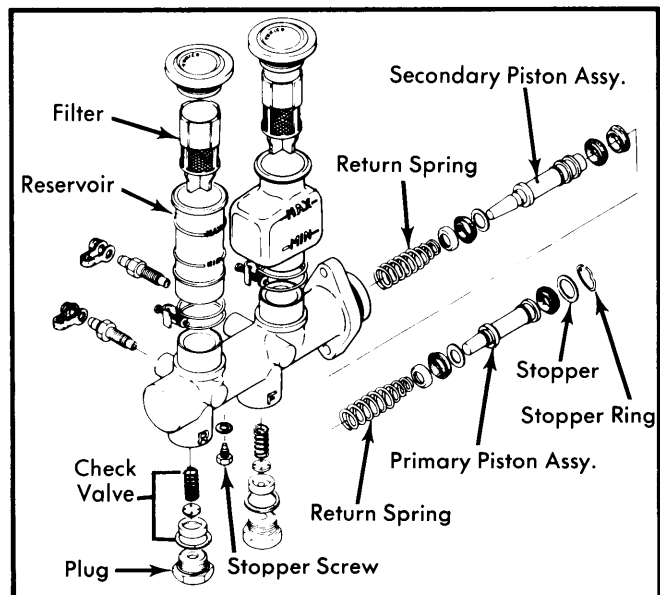

**Fig. 5 Exploded View of Datsun 200SX and B210 Master Cylinder — F10 Models Have Different Reservoir Arrangement**

## DATSUN F10, 200SX, B210 (Cont.)

**Inspecting** — Thoroughly clean all components in approved grade brake fluid. Inspect all components for excessive wear or damage and replace parts as necessary.

**Reassembly** — Reverse disassembly procedure and note the following: Coat all parts with brake fluid (rubber parts with brake grease) when assembling.

### POWER BRAKE UNIT

**Disassembly** — 1) Place power unit in a soft jaw vise with operating rod pointing up. Scribe an alignment mark on front and rear shell to assure reassembly in original position, then remove lock nut, clevis and dust boot from rear shell.

2) Place suitable wrench (ST08080000) over rear shell mounting studs. Press down on wrench while rotating counterclockwise and remove rear shell, then lift out diaphragm plate assembly, diaphragm spring and push rod assembly. Pry off retainer and remove bearing and valve body seal assembly.

3) Remove diaphragm from diaphragm plate assembly, then pry off air silencer retainer and remove silencer and filter. Rotate diaphragm plate assembly until valve plunger key slot is down, then press in on plunger and shake out stop key. Remove reaction disc from plate assembly. Detach flange from front shell and remove front seal assembly.

**Cleaning & Inspection** — Clean all parts in denatured alcohol and blow dry with compressed air. Inspect front and rear shells for wear or damage. If slight rust is found on inside surface of shells, polish clean with fine emery cloth. Inspect all parts for cracks, nicks, distortion or other damage and replace as necessary.

**Reassembly** — Reverse disassembly procedure and note the following: Apply a thin coat of silicone grease to parts before installation. When assembling front shell to rear shell ensure marks made during disassembly are aligned. After reassembly, measure distance from master cylinder mounting surface of power unit to end of power unit push rod; distance should be .38-.39" (9.8-10.0 mm). If distance is not to specifications, correct by adjusting end of push rod.

### TIGHTENING SPECIFICATIONS

Application	Ft. Lbs. (mkg)
Master Cylinder Attaching Nuts .....	6-9 (.8-1.2)
Hydraulic Lines .....	11-13 (1.5-1.8)
Rotor-to-Hub	
200SX & B210 .....	28-38 (3.9-5.3)
F10 .....	18-25 (2.5-3.4)
Caliper Mounting Bolts	
200SX & B210 .....	53-72 (7.3-9.9)
F10 .....	40-47 (5.5-6.5)

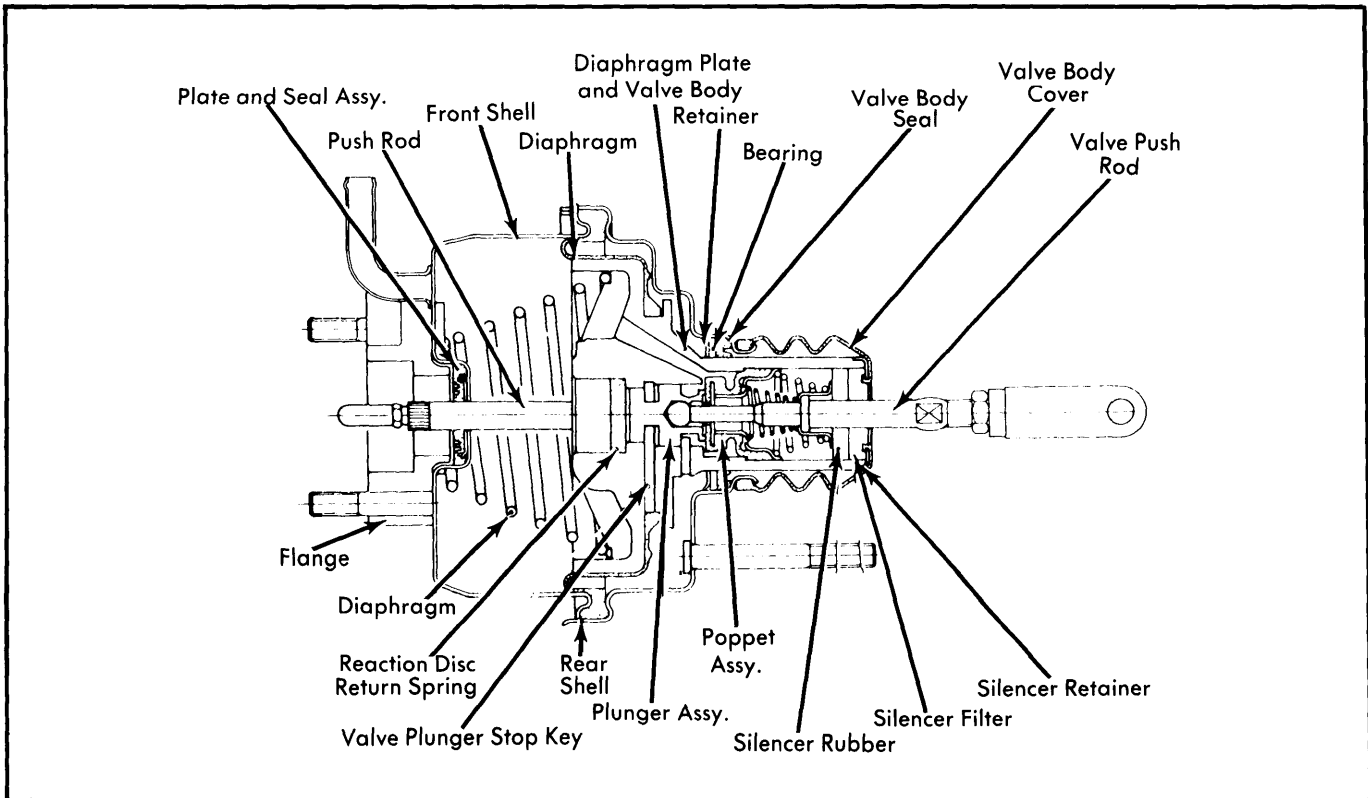

Fig. 6 Sectional View of Datsun Master Vac

# Brakes

## DATSUN F10, 200SX, B210 (Cont.)

DISC BRAKE ROTOR SPECIFICATIONS						
Application	Disc Diameter In. (mm)	Lateral Runout In. (mm)	Parallelism In. (mm)	Original Thickness In. (mm)	Minimum Refinish Thickness In. (mm)	Discard Thickness In. (mm)
F10	9.45 (240)	.005① (.13)	.....	.....	.339 (8.6)	②
B210	9.65 (245)	.0047① (.12)	.....	.374 (9.5)	.331 (8.4)	②
200SX	9.65 (245)	.0047① (.12)	.....	.394 (10.0)	.331 (8.4)	②

① — Maximum.

② — Less than minimum refinish thickness.

BRAKE LINING SPECIFICATION							
Application	Drum Dia. In. (mm)	Width		Length		Thickness	
		Front In. (mm)	Rear In. (mm)	Primary In. (mm)	Secondary In. (mm)	Primary In. (mm)	Secondary In. (mm)
F10 & B210	8.00 (203)	①	1.378 (35)	7.68 (195)	7.68 (195)	.189 (4.8)	.189 (4.8)
200SX	9.00 (228.6)	①	1.575 (40)	8.64 (219.5)	8.64 (219.5)	.177 (4.5)	.177 (4.5)

① — Front disc equipped.

BRAKE DRUM SPECIFICATIONS				
Application	Drum Diameter In. (mm)	Original Diameter In. (mm)	Maximum Refinish Diameter In. (mm)	Discard Diameter In. (mm)
F10 & B210	8.00 (203)	8.00 (203)	8.051 (204)	①
200SX	9.00 (228.6)	9.00 (228.6)	9.055 (230)	①

① — More than Maximum Refinish Diameter.

BRAKE SYSTEM SPECIFICATIONS				
Application	Drum Diam. In. (mm)	Wheel Cylinder Diameter		Master Cylinder
		Front In. (mm)	Rear In. (mm)	Diameter In. (mm)
F10	8.00 (203)	1.894 (48.1)	.687 (17.46)	.750 (19.05)
B210	8.00 (203)	2.012① (51.1)	.813 (20.64)	.750 (19.05)
200SX	9.00 (228)	②2.012 (51.1)	.813 (20.64)	.750 (19.05)

① — Caliper cylinder diameter.