

MAZDA POWER-ASSISTED RECIRCULATING BALL

RX4
Cosmo

DESCRIPTION

This torsion-bar type hydraulic assisted system furnishes power to reduce the amount of effort needed to turn the steering wheel. The system also reduces road shock and vibration. The power steering system includes a worm and one-piece rack piston which is meshed to the gear teeth on the steering sector shaft. The unit also incorporates a hydraulic valve, valve actuator, stub shaft and torsion bar which is mounted on the end of the worm shaft and operated by the twisting action of the torsion bar.

GENERAL SERVICE

LUBRICANT TYPE

ATF Type F (M2C33-F)

SERVICE INTERVALS

Check and add (if necessary) at first 2000 miles and every 6250 miles or 6 months. Change every 25,000 miles or 24 months whichever occurs first.

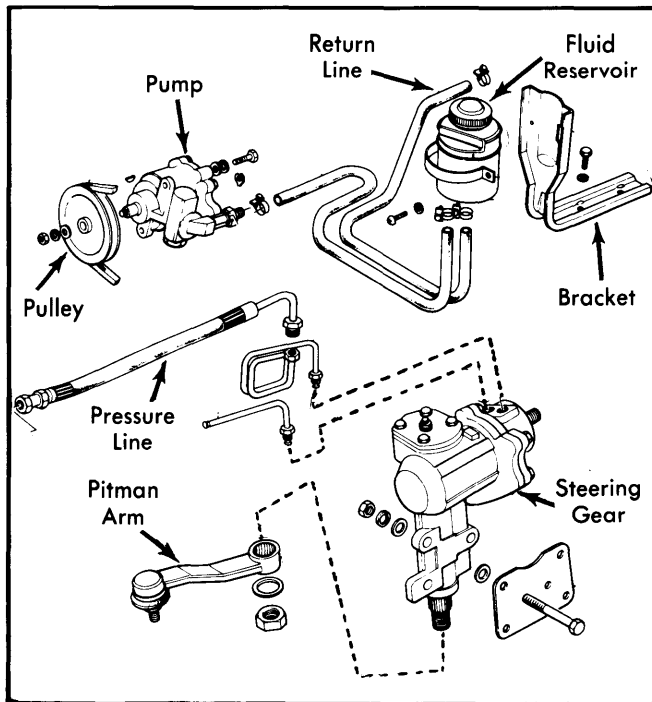

Fig. 1 Mazda Power Steering Components

HYDRAULIC SYSTEM BLEEDING

1) Fill the reservoir to the "FULL" mark and raise the front end of vehicle. To avoid foaming of the fluid during filling and testing, fabricate a stick, using the dimensions shown in Fig. 2.

2) Install the fabricated stick in reservoir with short end down into fluid return port on bottom of reservoir. Raise and support front of vehicle. With stick in position, turn steering wheel lock-to-lock at least ten times. Check fluid level and add if necessary.

NOTE — Do not let the reservoir run dry.

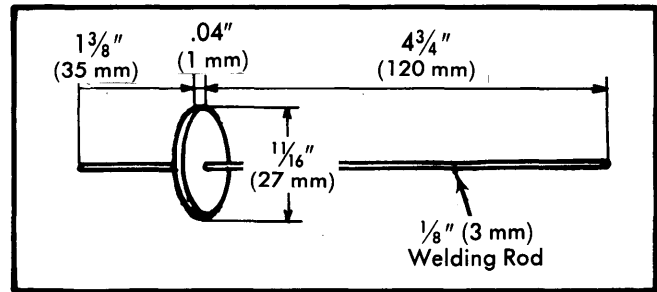

Fig. 2 Fabricated Tool

3) Attach a tube to the bleeder screw on the power steering gear. Insert open end of tube into a container partially filled with fluid.

4) Start engine and turn steering wheel to left lock position and open bleeder screw. Run engine until air bubbles cease to appear. Repeat operation with the steering wheel in the right lock position.

NOTE — Do not let the reservoir run dry.

5) Close the bleeder screw and fill reservoir to between the "FULL" and "LOW" level marks. **NOTE** - Do not overfill.

PUMP BELT ADJUSTMENT

Belt deflection should be $.35 \pm .04$ " (9 ± 1 mm) when pressure of approximately 22 lbs. (10 kg) is applied to belt halfway between pulleys. Adjust tension by turning adjusting bolt on idler pulley.

PUMP PRESSURE TEST

1) Install a pressure gauge with shut off valve in series with the pressure hose. Start the engine and set idle between 600-700 RPM. Check that fluid temperature in the reservoir is maintained between 122°-140°F (50-60°C).

2) Close pressure gauge shut off valve and check that pressure is between 782-896 psi (55-63 kg/cm²). If pressure is less than specifications, check for faulty pump or a sticking flow control valve.

3) Open shut off valve. Pressure should drop at least 71 psi (5 kg/cm²). If pressure drops more than this, check for bent or kinked lines or contaminated fluid.

4) With shut off valve open, turn steering wheel to full lock position, then release. If pressure drops more than 71 psi (5 kg/cm²), check for faulty valve in steering gear.

5) Turn steering wheel to full right and full left lock position. If pressure drops more than 71 psi (5 kg/cm²) with shut off valve open, look for excessive internal leakage in the power steering gear, caused by excessive valve clearances or broken seals.

REMOVAL & INSTALLATION

POWER STEERING GEAR

Removal — 1) Disconnect negative battery cable then remove engine oil filter cartridge to gain clearance for removal of the fluid lines. Disconnect and tag pressure and

MAZDA POWER-ASSISTED RECIRCULATING BALL (Cont.)

return lines for correct reassembly, then plug both lines and steering gear ports to prevent entry of dirt.

2) Raise vehicle and disconnect center link at pitman arm, then remove bolts and nuts securing steering gear housing to frame. Remove clamp bolt holding flexible coupling to steering gear, slide gear off coupling and remove steering gear from vehicle.

Installation — To install steering gear, reverse removal procedure, noting the following: Fill and bleed system, then start engine and check for leaks by turning steering wheel to left and right.

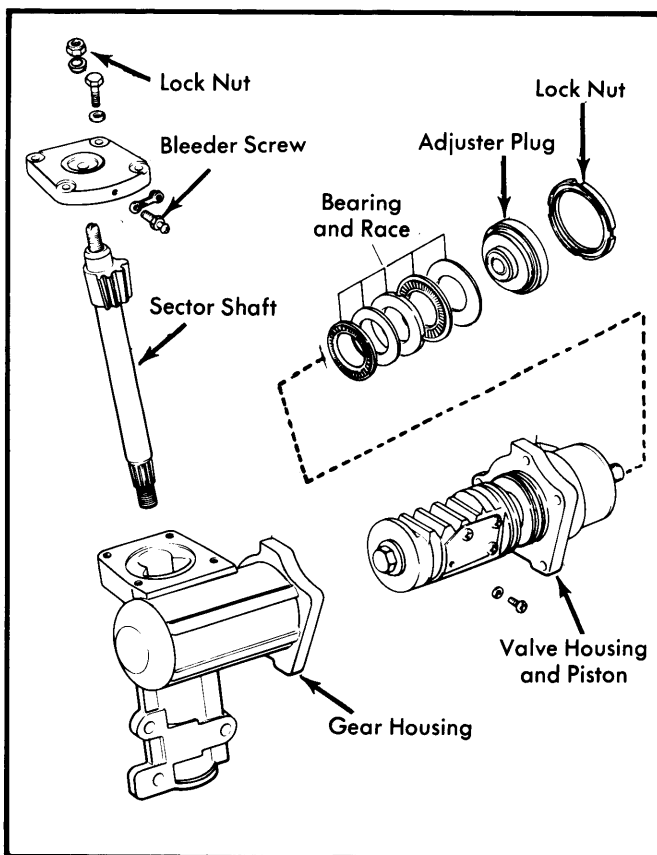

Fig. 3 Exploded View of Mazda Power Steering Gear

OVERHAUL

POWER STEERING GEAR

Disassembly — 1) Thoroughly clean the exterior of gear with solvent. Hold gear upside down over a drain pan and turn worm shaft back and forth several times to drain fluid, then secure gear on a work stand.

2) Remove pitman arm nut and using puller (49 0223 695D), remove pitman arm. Remove sector shaft adjusting screw lock nut. To center the gear, turn worm shaft until identification mark is in the position shown in Fig. 4.

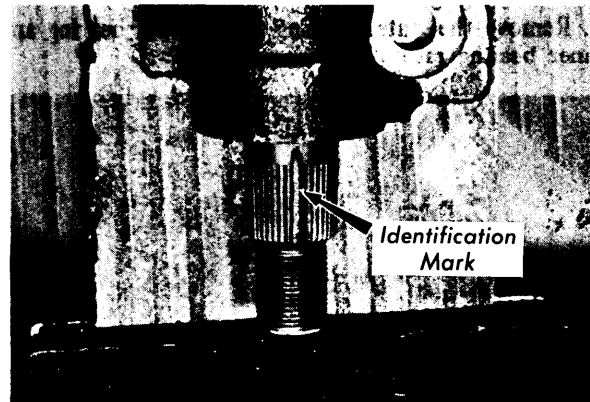

Fig. 4 Location of Identification Mark

3) Remove side cover attaching bolts. Tap lower end of sector shaft with soft hammer to loosen, then remove cover and shaft as an assembly. Turn side cover counterclockwise to remove cover from adjusting screw.

4) Remove adjuster plug lock nut, then loosen, but do not remove the adjuster plug. Unscrew valve housing attaching bolts and remove valve housing and worm shaft as an assembly from steering gear housing.

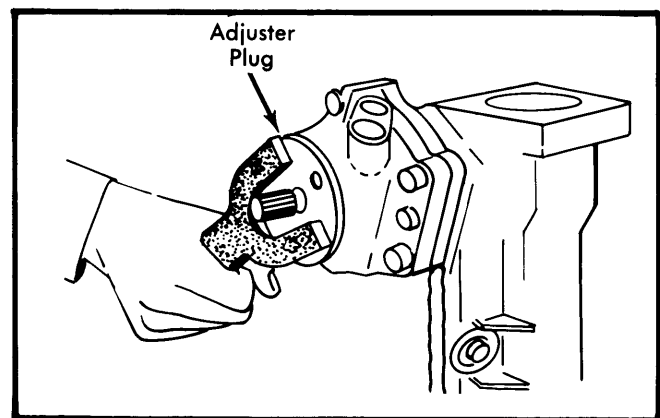

Fig. 5 Loosening Adjuster Plug

5) Stand valve body and piston on end with piston end down. Rotate worm shaft counterclockwise out of the piston letting the ball bearings drop into the piston. Turn the piston upside down and catch the 26 balls in a container. Unscrew ball guide cover screws, then remove cover and ball guides.

STEERING GEAR HOUSING

Disassembly — Clean and inspect housing. Replace seals, if necessary, as follows: Pry lower seal from lower end of housing and remove upper seal snap ring, spacer washer, and upper seal.

Reassembly — Dip new seals in gear lubricant and coat seal bore of housing with lubricant. Place upper seal in bore with lip facing inward. Install spacer washer, then seat snap ring in groove. Insert lower seal in bore with rubber side facing out and press into place.

MAZDA POWER-ASSISTED RECIRCULATING BALL (Cont.)

VALVE HOUSING, WORM SHAFT & VALVE

Disassembly – Unscrew adjuster plug from valve housing, then remove outer bearing race, thrust bearing and inner bearing race. Remove valve and worm shaft assembly, bearing races and thrust bearing from housing. Remove worm shaft bearing and pry oil seal and dust seal from adjuster plug. Remove Teflon ring and "O" ring from piston and ball nut.

Reassembly – 1) Install new Teflon ring and "O" ring in valve housing. Coat new Teflon rings and "O" rings in gear lubricant and install on valve body and worm shaft. Dip bearing races and needle bearing in power steering fluid and position on worm.

2) Lubricate Teflon ring and "O" ring with power steering fluid, then carefully install worm and valve in housing. Coat new dust seal and oil seal with power steering fluid, then install dust seal with rubber side facing out and oil seal with lip facing inward on adjusting plug.

3) Drive worm shaft bearing into adjuster plug until it seats on bottom surface of bearing bore. Coat bearing races and thrust bearing with power steering fluid, then align grooves on race with pins, thrust bearing, and outer race, install on valve body.

4) Lubricate and install "O" ring in adjuster plug groove and place adjuster plug over end of stub shaft. Tighten adjuster plug enough to properly seat all parts, then tighten until initial preload is to specifications. Install, but do not tighten adjuster plug lock nut.

5) Coat new "O" ring in gear lubricant, then install "O" ring and new Teflon ring on piston and ball nut.

NOTE – Do not stretch Teflon ring more than necessary.

STEERING GEAR ASSEMBLY

1) Lubricate and install "O" ring in valve housing. Insert worm shaft into piston so that three grooves are visible between valve housing and ball nut, then place 19 balls into hole near Teflon ring as worm is turned clockwise. Insert remaining seven balls into one side of ball guide, hold in place with Vaseline, then position other half of ball guide over balls and install in piston.

2) Apply Vaseline to new "O" ring and install on cover. Make sure neoprene pad is in cover, then position cover on ball nut and tighten attaching screws to specification. Use a straightedge to make sure guide cover head is not higher than Teflon ring. File off high spots.

NOTE – Do not rotate piston or stub shaft after balls are inserted, as balls may fall out of circuit.

3) Coat new "O" ring with Vaseline and install in pressure port of gear housing. Coat Teflon seal with Vaseline and install on piston, then insert piston and valve into gear housing. Align lube passages in valve housing with passages in gear housing and install, but do not tighten, attaching bolts.

4) Rotate ball nut until teeth mesh with sector teeth then tighten valve housing bolts to specification. Insert side cover "O" ring in steering gear housing, then turn stub shaft to

center the piston. Screw side cover onto adjusting screw until it bottoms, then back out one and one half turns.

5) Lubricate sector shaft bearing and journal, then install sector shaft with center gear tooth meshing with center groove of rack piston. Install side cover attaching bolts and lock washers and tighten to specification.

NOTE – Make sure cover "O" ring is in place before tightening bolts.

6) Turn stub shaft completely to left or right, then back 90°, then using pull scale, recheck that initial preload is to specifications. Turn sector shaft adjusting screw to adjust final preload to specifications. Install new rubber seal and adjusting screw lock nut, then tighten lock nut to specifications. Align identification marks and install pitman arm on sector shaft and tighten nut to specifications.

POWER STEERING PUMP

Disassembly – 1) Clean pump exterior and drain fluid. Clamp pump in padded vise. Remove pulley and Woodruff key. Unscrew suction line connector attaching bolts and remove connector. Remove flow control plug, valve and spring from housing.

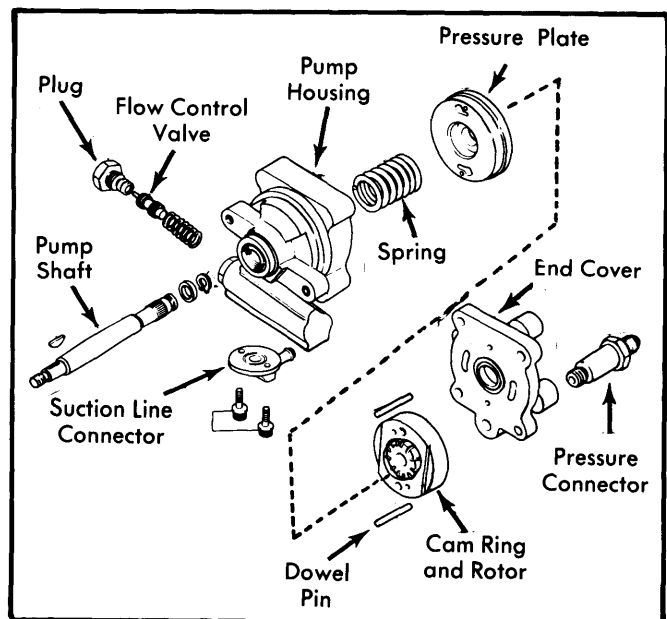

Fig. 6 Exploded View of Mazda Power Steering Pump

2) Remove end cover attaching bolts and end cover. Take off snap ring then remove collar, vanes and rotor from shaft. Remove cam ring, and tapping drive end of shaft with plastic hammer, drive out pressure plate and shaft.

3) Remove dowel pins from housing. Pry shaft seal from housing (if defective)

NOTE – The seal will be destroyed if removed.

Inspection - Clean parts thoroughly and check for cracks, wear or burned areas. Rotor, vanes and ring must be replaced as an assembly if defective. Check flow control valve and plug orifices.

MAZDA POWER-ASSISTED RECIRCULATING BALL (Cont.)

Reassembly – 1) If shaft seal was removed, install new seal with metal backing facing pump end of shaft. Seat seal properly in shaft hub.

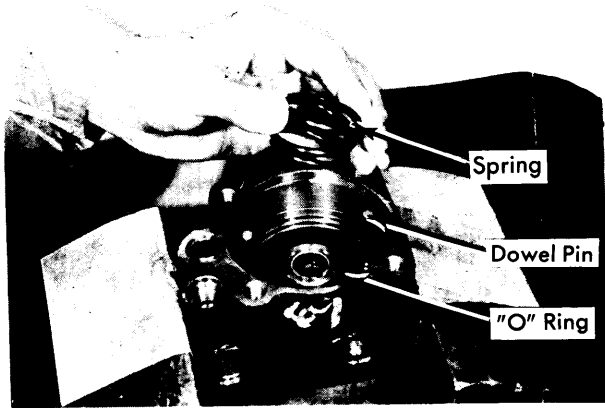

Fig. 7 Installing Dowel Pin and Spring

2) Lubricate new "O" ring with power steering fluid and install in groove on pump body. Install both dowel pins and spring, then insert shaft in housing. Install new "O" ring on pressure plate, then coat plate and "O" ring with power steering fluid. Install pressure plate on dowel pins with recess facing out and press into place. Place cam ring on dowel pins with rotation arrow toward pressure plate.

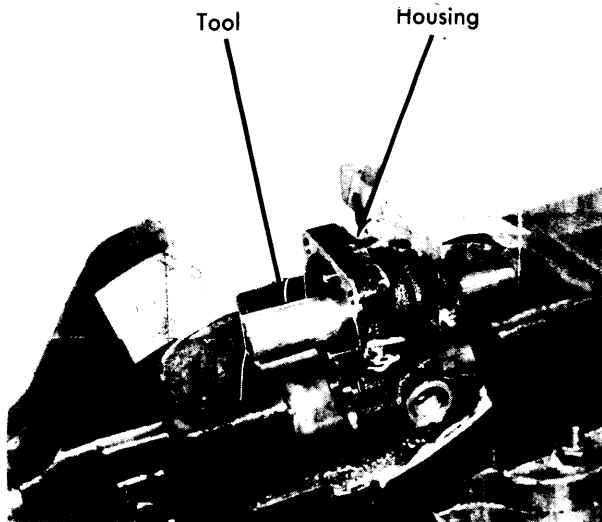

Fig. 8 Installing Pressure Plate

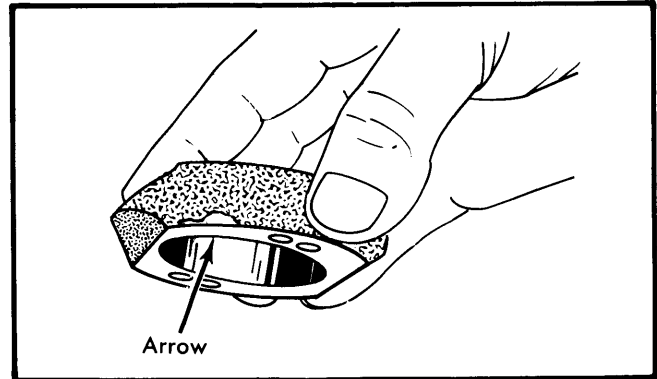

Fig. 9 Cam Ring Locating Mark

3) Coat rotor with gear lubricant and install on shaft with recessed chamfer side of bore toward pressure plate. Install vanes in rotor slots with rounded edge of vanes facing out. Make sure vanes move freely. Install collar and snap ring on splined end of shaft, sliding snap ring down until seated into ring groove.

4) Lubricate new "O" rings with power steering fluid and install on housing, then install end cover and tighten attaching bolts to specification. Place flow control valve spring and valve in hole, making sure pin end of valve is toward plug. Lubricate new "O" rings and install on plug, then install plug in housing tighten to specification.

5) Lubricate new "O" rings and install on pressure connector and suction line connector. Tighten pressure connector and suction line connector bolts to specification. Tap Woodruff key into shaft and install pulley on pump.

TIGHTENING SPECIFICATIONS

Application	Ft. Lbs. (mkg)
Valve Housing Bolts	29-36 (3.8-5.0)
Side Cover Bolts	29-36 (3.8-5.0)
Pitman Arm Nut	108-130 (15-18)
Pump End Cover Bolts	22-29 (3-4)
Pump Control Valve Plug	50-72 (7-10)
Pump Pressure Connector	50-72 (7-10)
Pump Suction Connector Bolts	5-7 (.7-1.0)
Application	INCH Lbs. (cmkg)
Worm Shaft Initial Preload	5-9.5 (6-11)
Worm Shaft Final Preload	9-14 (10-16)