

LANCIA POWER-ASSISTED RACK & PINION

Lancia Beta
Coupe
Sedan
HPE

DESCRIPTION

Lancia models have an optional power-assisted rack and pinion steering system. The power assist pump is located just to the right of the engine crankshaft and is belt-driven. The non-integral fluid reservoir is situated directly above the pump.

MAINTENANCE

PUMP BELT

Vehicles built after the following serial numbers have modified cog belts to eliminate excessive whining noise: Sedan-504571, Coupe-607379, HPE-701572. Cars built before these serial numbers may have a slight whining noise from the belt. This is normal. Do not replace belt on these cars unless belt is worn or damaged.

CHANGING & BLEEDING FLUID

1) Remove banjo bolts from power steering pump inlet and outlet ports. Take cover from reservoir. Disconnect ignition coil high tension lead.

NOTE — On air conditioned vehicles it will be necessary to remove right front wheel and splash guard to gain access to banjo bolts.

2) Turn steering wheel from lock-to-lock and crank engine intermittently to ensure all fluid is drained. Replace banjo bolts, using new washers.

CAUTION — When fluid is drained, DO NOT continue to crank engine as power steering pump will be damaged.

3) Check pump fluid reservoir filter and replace if necessary.

4) Fill reservoir with fresh fluid while intermittently cranking engine to draw fluid into pump.

5) When fluid level indicates full and remains constant, stop cranking engine and connect ignition coil lead.

6) Start engine and run at idle. Watch level of fluid in reservoir. Refill as required to maintain full level.

7) While idling engine, turn steering wheel from lock-to-lock several times until no air bubbles are seen in fluid reservoir.

8) Check all hose connections for any leakage. Stop engine and note that fluid level will rise slightly. Install reservoir cover.

REMOVAL & INSTALLATION

FLUID RESERVOIR

Removal — 1) Remove power steering pump fluid inlet banjo bolt and allow reservoir to drain. If equipped with A/C, remove right front wheel and splash guard to gain access to bolt.

2) Remove cover from reservoir, remove clips and detach hoses from reservoir. Remove support bracket and reservoir from vehicle.

Installation — To install, reverse removal procedure, using new washers for banjo bolts. Fill and bleed system.

POWER STEERING PUMP

Removal — 1) Raise front of vehicle and support on frame stands. Remove right front wheel and splash guard. Remove wheelhousing guard.

2) Place container under pump, remove inlet banjo bolt from pump and drain fluid.

3) In non-A/C, hold pump drive belt and remove pulley nut. Unscrew top bracket adjusting bolt and remove belt. Remove outlet banjo bolt. Slacken alternator and remove pump mounting through-bolt. Lift pump assembly and bracket from vehicle.

4) If equipped with A/C, remove air cleaner and loosen compressor mounting. Remove pump pulley nut and remove cogged drive belt. Take off pump pulley. Remove outlet banjo bolt and rear bracket. Remove pump mounting screws and remove pump.

Installation — To install, reverse removal procedure, using new banjo bolt washers. Also, set pump belt to proper tension. Fill and bleed fluid system.

POWER-ASSISTED RACK & PINION ASSEMBLY

Removal — 1) Disconnect battery. Remove steering shaft joint bolt, located inside passenger compartment. Remove steering column lower casing, disconnect column from dash and rest on front seat.

2) Raise front of vehicle and support on frame stands. Remove front wheels.

3) Remove cooling system overflow tank. Place container under steering rack, remove fluid outlet tubing from housing and drain fluid.

4) Detach tie rod end ball joints from steering knuckles. Remove guards from tie rod housing. Remove EGR system lower piping and exhaust pipe front heat shield.

5) Remove rack and pinion steering assembly mounting bolts and lift assembly out left side of vehicle.

Installation — To install, reverse removal procedure, after setting rack in central position. Use new banjo bolt washers. Refill and bleed fluid system.

OVERHAUL

RACK ASSEMBLY

Disassembly, TRW Models — 1) Loosen clip on rubber cap at end of housing and drain oil. Install housing in vise, knock down lock plate, remove bolts and lift off steering rods from rack housing.

LANCIA POWER-ASSISTED RACK & PINION (Cont.)

2) Remove mounting clamp insulators, loosen clips and remove rubber cap and guard from housing. Remove bolts from locating support cover and withdraw shims with seal, spring, and rack locating support.

3) Straighten lock and remove pinion cover, seal, shims, and drive pinion together with upper bearing. Slide out rack and plastic bushing from housing. Remove lower bearing.

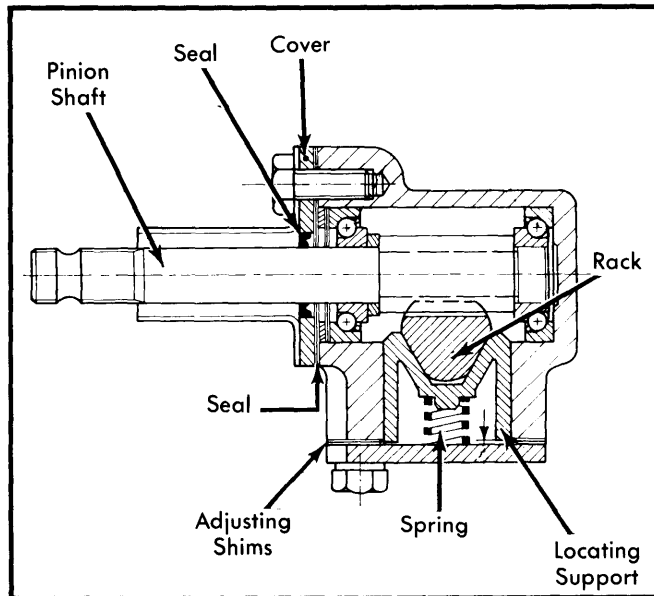

Fig. 1 Sectional View of TRW Steering Rack Housing

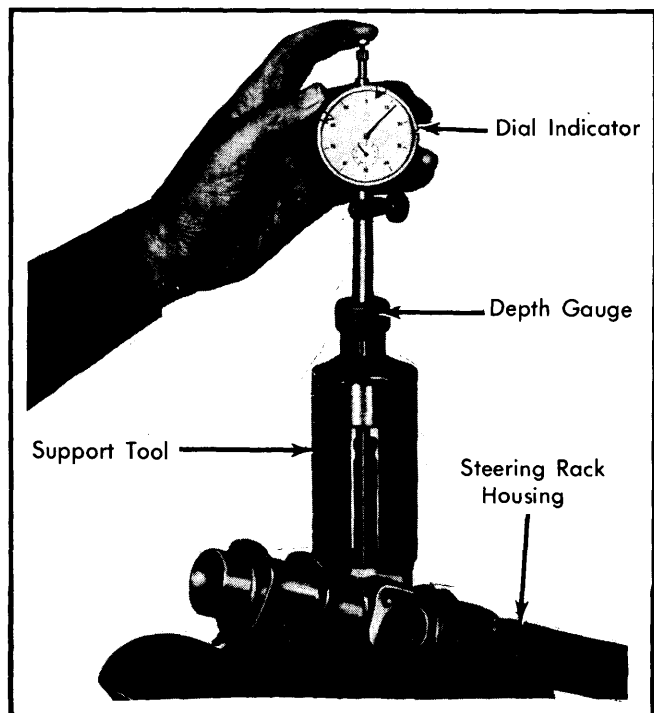

Fig. 2 Setting Bearing Pre-Load

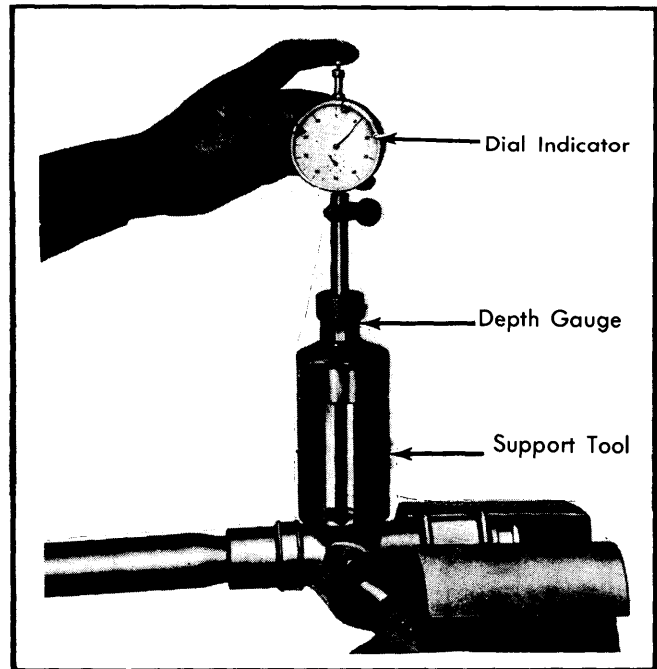

Fig. 3 Setting Backlash

Reassembly - 1) Using seal replacement tool (88062031), replace seal in pinion cover. Insert plastic bushing in rack housing and position so three locating gears engage seats in housing. Install drive pinion together with bearing and .09" (2.3 mm) washer to steering box.

2) Check bearing pre-load by installing support tool (88065001) on rack housing, then install depth gauge (88095851) with 4.7" (120 mm) long stem. Using dial indicator, set indicator on rack housing surface and measure between housing surface and washer.

3) Add value indicated to thickness of cover gasket, .010" (0.25 mm), and to value required to obtain pre-load, .001-.005" (.025-.13 mm). Install required shims, washer, cover, and mounting bolts. Torque bolts to 14.5 ft. lbs. (2 Mkg).

NOTE - Shims are available in .005" (.13 mm), .007" (.19 mm), .010" (0.25 mm) and .09" (2.30 mm) thicknesses.

4) Using extension and torque wrench, check turning torque for .6 ft. lbs. (.085 Mkg). To check backlash, remove cover, pinion with shims and upper bearing and insert rack. Install pinion, meshing it with rack teeth. Install shims between bearing and washer and install cover and bend lock plate.

5) Install support tool (88065001) and using dial indicator measure between housing face and top of support sticking out of housing. Add this value to backlash specifications, .002-.004" (.05-.10 mm). Then subtract thickness of cover seal, .009" (0.25 mm). This will give shim thickness required.

NOTE - Shims are available in .002" (0.06 mm), .005" (.13 mm) and .01" (.25 mm).

Power Steering

LANCIA POWER-ASSISTED RACK & PINION (Cont.)

6) Install spring to rack locating support. Install shims, cover and pinion cover mounting bolt. Torque bolt to 14.5 ft. lbs. (2 Mkg). Install rubber cover and cap to housing end. Install spacers and lock clips.

NOTE — To ensure tightness to rack housing, coat bolts and edges of shims with sealing compound.

Disassembly, Z.F. Models — 1) Remove damper from steering rack housing. Remove caps and install housing in vise. Knock down tabs and remove screws, disconnect steering rods. Remove buffers from housing. Remove clips, dust covers, sleeve and link from recess in housing.

2) Remove cap and cotter pin. Using spanner tool (88061024) remove adjuster and take out spring and support. Remove rack from housing, position housing with worm shaft facing upwards, remove cap and lift up retainer ring. Using spanner tool, remove adjuster.

3) Install worm shaft in vise, using rawhide or rubber mallet, hit housing lightly and remove worm shaft with bearing. Remove plastic bushing and rack "O" ring.

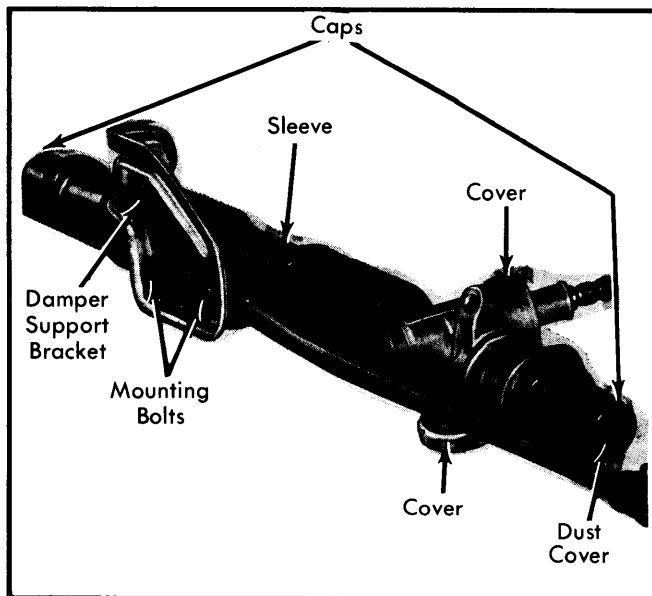

Fig. 4 Z.F. Model Steering Rack Housing

Reassembly — 1) Install new "O" ring and plastic bushing in rack housing, so that two locating gears engage with seats in housing. Using bearing installer (88022093), install worm shaft and bearing. Install and screw in adjuster.

2) Lightly grease rack and insert into housing and grease teeth of rack. Mesh rack with worm shaft and set steering rod mounting bores at center of slot. Grease and install support and spring. Tighten adjuster.

3) Install connector (88063006) to worm shaft. Using torque wrench, check turning torque, .6 ft.lbs. (.085 Mkg). Loosen adjuster as needed to install cotter pin and disconnect connector from worm shaft. Install retainer ring, fill recess in ring with grease and install caps. Install link to rack, dust covers and sleeve. Tighten mounting clips and install rubber caps.

4) Fit the steering rods and damper support bracket by inserting the washers. Locate steering rods horizontally, tighten screws and bend lock plate. Fit the damper.

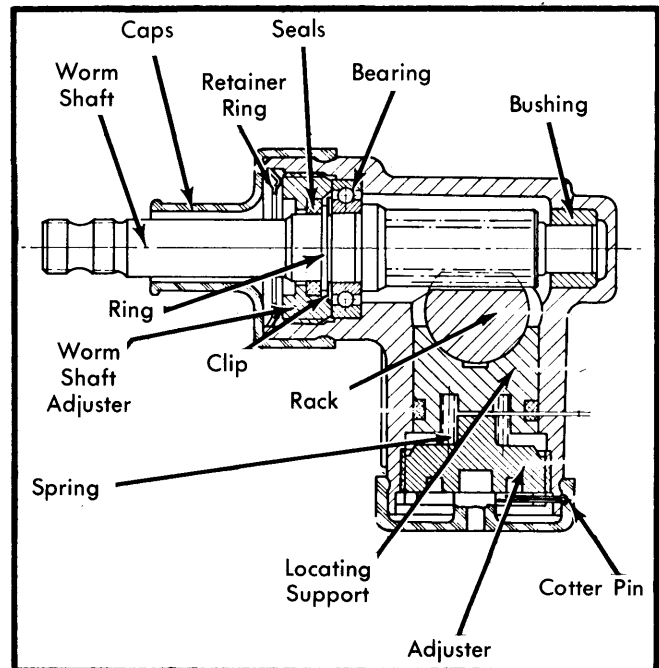

Fig. 5 Sectional View of Z.F. Model Steering Rack Housing