

# Power Steering

## CAPRI POWER-ASSISTED RACK & PINION

Capri

### DESCRIPTION

Power steering gear is a hydraulic-mechanical unit using an integral piston and rack design to provide power assisted steering control. Internal valving directs pump flow and controls pressure to reduce steering effort. Unit contains rotary hydraulic fluid control valve integrated to input shaft and a boost cylinder integrated with rack.

### TESTING

#### STEERING SYSTEM TEST

1) Check belt tension, tire pressure and fluid level and adjust as necessary. Run engine at 1500 RPM and slowly turn steering wheel from lock to lock to bring power steering fluid to 158°F (70°C).

**NOTE** — Do not turn wheels from lock-to-lock more than five times.

2) Place steering wheel in straight ahead position and make sure wheels are on a clean dry surface. With a torque wrench on the steering wheel nut, measure torque required to keep steering wheel turning. Torque should be 6 ft. lbs. (.8 mkg).

#### PUMP PRESSURE TEST

1) Disconnect pressure line from pump and connect gauge side of a suitable power steering pressure tester to pump and pressure line to valve side of tester. Make sure valve on tester is open and fluid is at proper level. Start engine and turn steering wheel lock to lock a few times to remove any air in system. Add fluid if necessary.

2) With power steering fluid at 158°F (70°C) and engine running at 1500 RPM, turn steering wheel to lock and hold momentarily. Pressure should be 740 psi (52 kg/cm<sup>2</sup>). If pressure is below specification, hydraulic system is faulty. With engine at 1500 RPM and wheels in straight ahead position, slowly close valve on tester. If pressure drops below specification, pump is faulty. If pressure rises above specification, steering gear control valve, rack piston or piston seals are faulty.

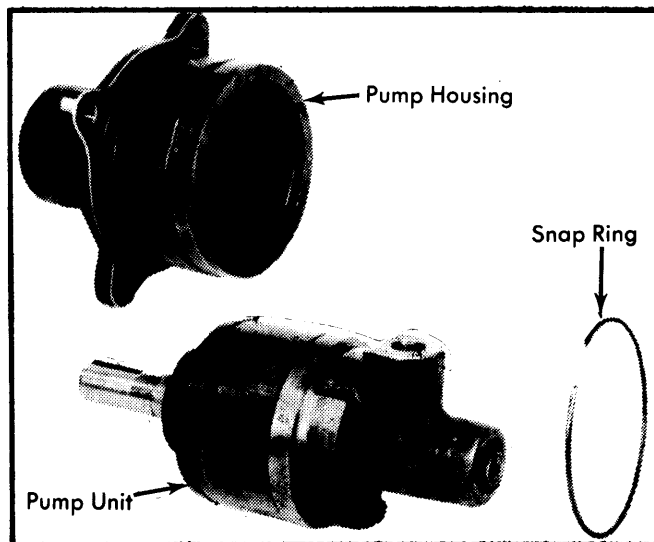

Fig. 1 Capri Power Steering Pump

### REMOVAL & INSTALLATION

#### STEERING GEAR

**Removal** — Disconnect fluid lines from steering gear and allow fluid to drain. Remove steering coupler lower clamp bolt (mark splines for alignment on installation) and disconnect tie rod ends from steering arms. Remove steering gear assembly-to-frame mounting bolts and remove steering gear from vehicle. Remove the tie rod ends from tie rods (note number of turns for installation alignment).

**Installation** — Install tie rod ends with the same number of turns noted when removed. Position steering gear assembly in vehicle, aligning pinion shaft splines with lower coupler, and secure with bolts.

#### POWER STEERING PUMP

**Removal** — Disconnect fluid lines and allow fluid to drain. On 2300 cc engines, disconnect fuel pump and position out of way (it is not necessary to disconnect fuel lines from pump). Remove power steering pump (on 2800 cc engines, remove pump with bracket assembly) from vehicle.

**Installation** — To install, reverse removal procedure and fill pump or reservoir with suitable power steering fluid (D2AZ-19582-A).

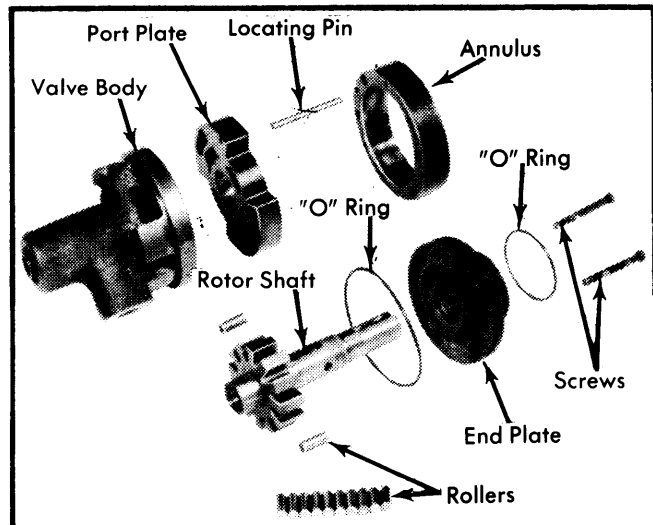

Fig. 2 Disassembled View of Capri Power Steering Pump

### OVERHAUL

#### STEERING PUMP

**Disassembly** — With pump removed from vehicle, remove hub and key from pump shaft. On 2300 cc engines, remove pressure line from reservoir. Mark pump to pump housing for alignment during assembly. Remove snap ring and tap on pump shaft to remove pump unit from housing. Remove the two screws holding end plate to pump unit and remove end plate. **NOTE** — Do not remove the Allen screw at rear of pump. Remove "O" ring from end plate. Remove rotor shaft, annulus, locating pin, and port plate from valve body. Remove snap ring retaining bearing in valve body, then remove bearing and seal.

## CAPRI POWER-ASSISTED RACK & PINION (Cont.)

**Assembly** — Install seal (with seal lip facing into body) in valve body. Lubricate port plate, locating pin, and annulus with power steering fluid and install to valve body. Install rotor shaft with rollers in annulus. Lightly grease "O" rings and position on end plate, then install end plate with screws. Install pump unit to pump housing, aligning scribe marks, and secure with snap ring.

2) Remove control valve cover plate, bearing, seal, carrier assembly and spool preload spring from control valve body, then remove control valve body from pinion shaft. Remove rack adjusting bearing cover plate, shim pack, sealing ring, spring, and adjusting bearing.

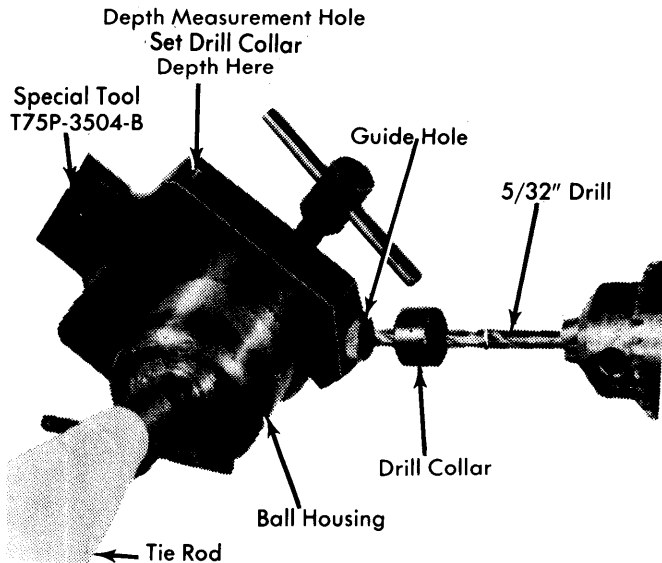

Fig. 3 Tie Rod Housing Removal

### STEERING GEAR

**Disassembly** — 1) With steering gear removed from vehicle, remove rubber boots from tie rods and drain fluid. Mount assembly in a vise and loosen lock nut holding tie rod ball housing. To loosen lock nut use special tool T75P-3504-B with a 5/32" drill and drill collar. Install special tool (see Fig. 4) and drill out lock pins. **NOTE** — Special tool has a depth hole to set drill collar on drill bit. Then remove housing with tie rod, nylon seat, washer and spring. Remove fluid lines from control valve to rack assembly.

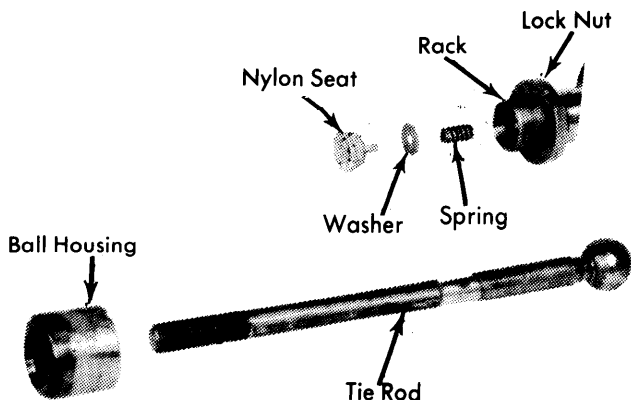

Fig. 4 Exploded View of Tie Rod Assembly

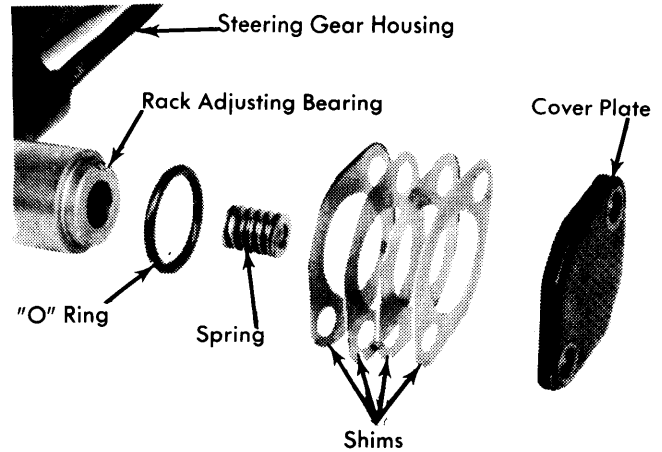

Fig. 5 Rack Adjusting Bearing Assembly

3) Position gear assembly in a vise and using a suitable tool that will lock onto splines of pinion shaft (tool T75P-3504-E), remove pinion bearing nut. Remove bearing outer race, then turn gear housing so pinion bearing is up. Remove bearing from pinion shaft and shaft from housing. Remove bearing inner race from housing.

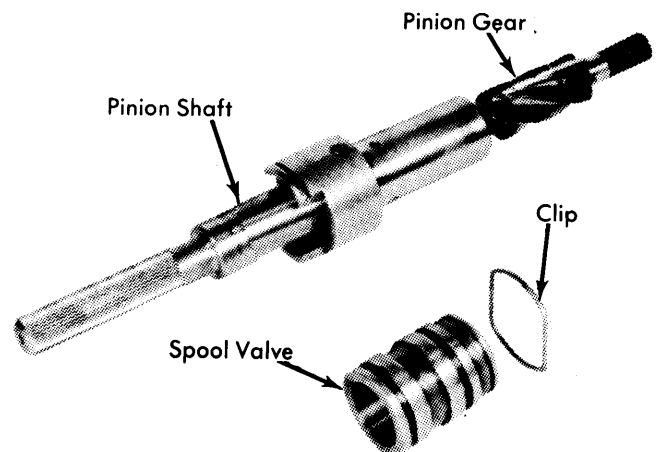

Fig. 6 Pinion Shaft Disassembled

4) Remove clip and spool valve from pinion shaft. Remove locating pegs from gear housing. Tap end housing and separate joint at rack tube. Pull rack towards end housing and remove rack and support bearing. Remove inner tube from rack tube. Note seal, washer and snap ring order.

## CAPRI POWER-ASSISTED RACK &amp; PINION (Cont.)

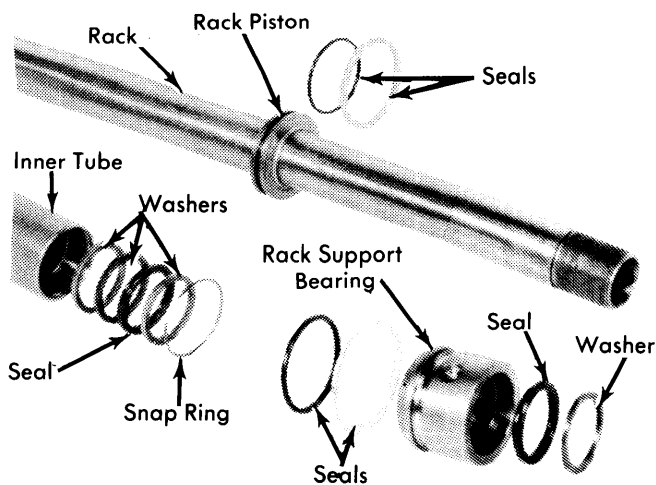

Fig. 7 Steering Rack Disassembled

5) Clean and inspect all components. Check rack and pinion teeth for damage or wear. Check bearings for wear, pitting or scoring. Replace components as necessary.

**NOTE** — Use new seals when assembling power steering gear assembly.

**Assembly** — 1) Install washers, seal and snap ring onto gear end of rack. Then slide inner tube onto rack. Install seal on a suitable seal protector (T75P-3504-H) and slide protector past rack teeth to smooth part of rack, slide seal off and remove seal protector. Lubricate two seals with power steering fluid and install in gear housing. Install snap ring and washer on inner tube then push tube into gear housing.

2) Slide rack through inner tube and gear housing. Install seals on inner tube and slide washers on rack to inner tube, then install snap ring. Soak "O" ring and nylon piston ring in power steering fluid. Install "O" ring and piston ring in groove of piston on rack. Compress piston ring and slide rack outer tube over piston and into gear housing. Rack tube end with one round and one oval hole should be towards gear housing. Align locating peg holes and install pegs.

3) Install outer seals to rack support bearing and slide bearing onto rack aligning peg holes. Using seal protector, install inner seals to rack support bearing. Lubricate large washer and "O" rings with power steering fluid and install in end housing. Position seals on transfer pipe and install pipe in gear housing. Slide end housing over rack, rack tube and transfer pipe. Align locating peg holes and install peg and washer.

4) Install inner bearing race to gear housing. Install spool valve to pinion shaft and secure with clip. Install oil seal next to middle pinion shaft bearing. Position lower bearing half cup to gear housing and position rack in steering gear assembly so that equal amounts extend from each end of steering gear assembly. Slide pinion shaft into gear housing, make sure that flat on pinion shaft faces center of rack assembly.

5) Screw lower bearing seat onto pinion shaft. Adjust bearing so that when pinion shaft float is removed, there is 1.62" (41.15 mm) between gear housing flange and top of spool valve (see Fig. 9). Install shim and pinion shaft end cover to gear housing, torque bolts to 9-12 ft. lbs. (1.2-1.7 mkg). Recheck gear housing flange to top of spool valve. If measure-

ment changed, measure gap between cover plate and gear housing (take measurement adjacent to bolts). Install shims .001-.002" (.025-.051 mm) thicker than measurement. If shims were needed, readjustment of gear housing flange to spool valve measurement is necessary.

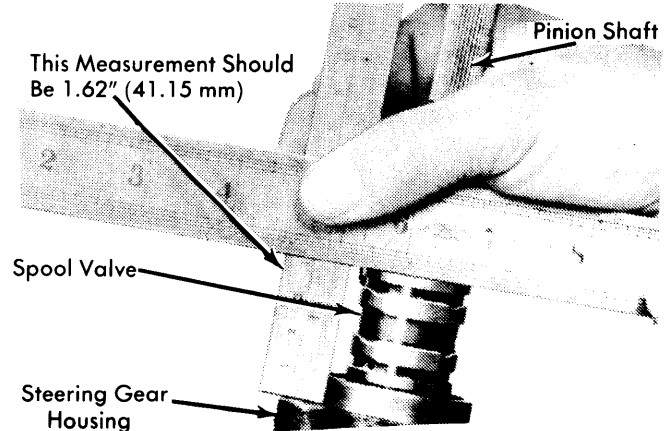

Fig. 8 Pinion Shaft Adjustment Procedure

6) Install control valve body, pinion bearing preload spring and bearing, and valve body cover plate. Tighten bolts. Attach fluid lines from control valve body to steering gear assembly.

7) Place rack adjusting bearing in gear housing, then using dial gauge and mounting block (T75P-3504-J) measure bearing deflection. Zero dial gauge and mount block on rack adjusting bearing, then turn pinion shaft so rack goes from lock to lock and record maximum gauge deflection from zero. Assemble a shim pack that is .001-.005" (.025-.27 mm) thicker than maximum deflection. With shim pack assembled, install spring, seal, shim pack and cover plate. Tighten cover plate bolts.

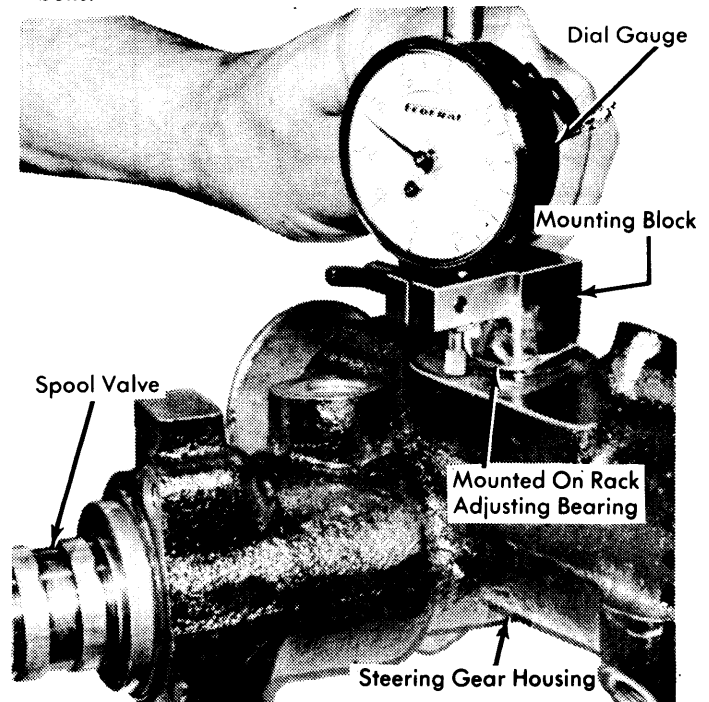
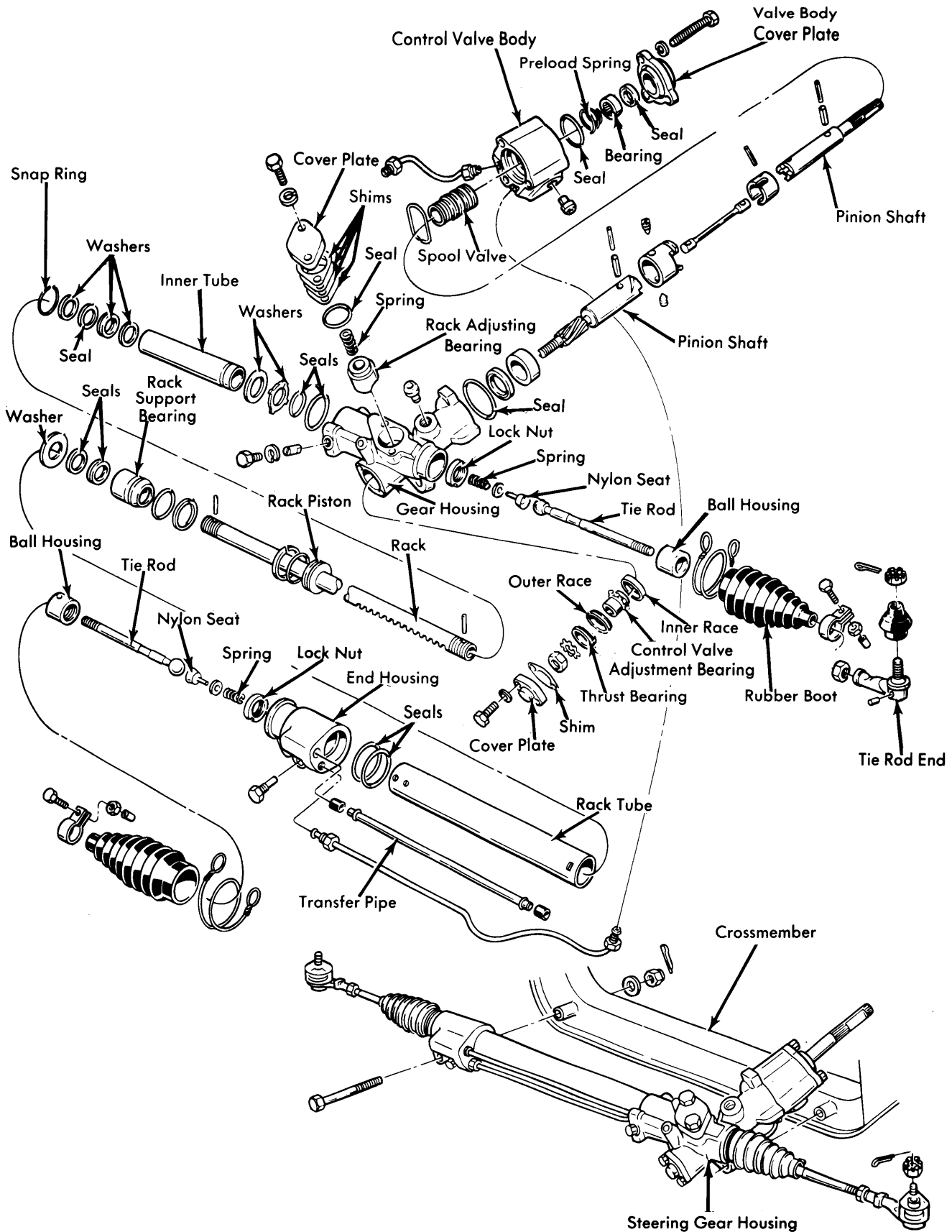

Fig. 9 Measuring Rack Adjusting Bearing Deflection

## CAPRI POWER-ASSISTED RACK & PINION (Cont.)



**Fig. 10 Capri Power Assisted Rack & Pinion Steering (Exploded View)**

# Power Steering

## CAPRI POWER-ASSISTED RACK & PINION (Cont.)

**8)** Lubricate and assemble tie rods then install tie rods to rack. Check turning effort of tie rods by locking two nuts to tie rod ends and turning with a torque wrench. Turning torque should be 5 ft. lbs. (.7 mkg). If torque is greater loosen ball housing and if less tighten ball housing. Recheck turning torque.

**9)** Hold ball housing from rotating on tie rod and tighten lock nut against ball housing to 25-35 ft. lbs. (3.5-4.8 mkg). Using special tool T75P-3504-B installed on ball housing and lock nut, drill a  $\frac{5}{32}$ " hole in line of contact between lock nut and ball housing. Use the depth measurement hole on special tool for depth to drill hole. Drill hole opposite existing hole. Insert pin and stake hole to secure pin.

**10)** Install one rubber boot, add 1/3 pint of lubricant (SAE 40 engine oil) and install other rubber boot. Do not tighten boot clamps until gear assembly is installed in vehicle. Install gear assembly in vehicle.

**11)** To check control valve adjustment, connect pump pressure test gauge as described in PUMP PRESSURE TEST. Start engine and allow power steering fluid to reach normal operating temperature. With engine running, turn wheels from lock to

lock. When wheels are in each lock position apply 34 INCH lbs. (39 cmkg) of torque to steering wheel nut and record pressure from gauge. Pressure should be 160 psi (11.25 kg/cm<sup>2</sup>) in the lock position with a maximum difference of 12 psi (.8 kg/cm<sup>2</sup>) from side to side.

**12)** If pressure is not within specifications, turn lower bearing to equalize pressure. Turning bearing 20° will change pressure by 25 psi (1.8 kg/cm<sup>2</sup>). With pressure equalized at 160 psi (11.25 kg/cm<sup>2</sup>) at each lock position, install cover plate and check fluid level.

TIGHTENING SPECIFICATIONS	
Application	Ft. Lbs. (mkg)
Fluid Lines	
Pressure .....	19-23 (2.6-3.2)
Return .....	12-15 (1.7-2.1)
Pinion Bearing Cover Plate .....	7.5-9 (1-1.2)
Rack Slipper Cover Plate .....	7.5-9 (1-1.2)