

Steering Gears & Linkage

VOLKSWAGEN TYPE 1 & DASHER RACK & PINION

Type 1
Dasher

DESCRIPTION

These vehicles are equipped with an adjustable rack and pinion steering gear. Attached to center of the rack housing are two tie rods (one adjustable and one non-adjustable). The Dasher uses a steering damper.

REMOVAL & INSTALLATION

Removal, Dasher - 1) Bend back tabs on locking plate at center of rack housing and remove both tie rod bolts. Move tie rods so that gear will have clearance for removal.

2) Unbolt pinch clamp at pinion-to-column connection. Remove lower instrument panel. Loosen steering column flange at toe board. Drive steering flange tube off of steering gear.

3) Remove gear mounting screw at right end of rack housing, then unbolt rack mounting at left end. Turn front wheels to right lock, and remove steering gear through right wheel housing.

Removal, Type 1 - 1) Raise vehicle and remove front wheels. Uncover lower universal joint by moving boot, then remove universal joint clamp bolt.

2) Pry universal joint shaft off pinion. Bend up lock plate and remove bolts holding tie rod inner end to steering rack.

3) Disconnect tie rods. Remove nuts and bolts holding ends of steering rack housing to brackets, then remove rack and pinion assembly from vehicle.

NOTE - For earlier non-adjustable models, there is a change-over kit available. When installing kit follow manufacturers instructions and **DO NOT** reinstall shims between housing and cover plate.

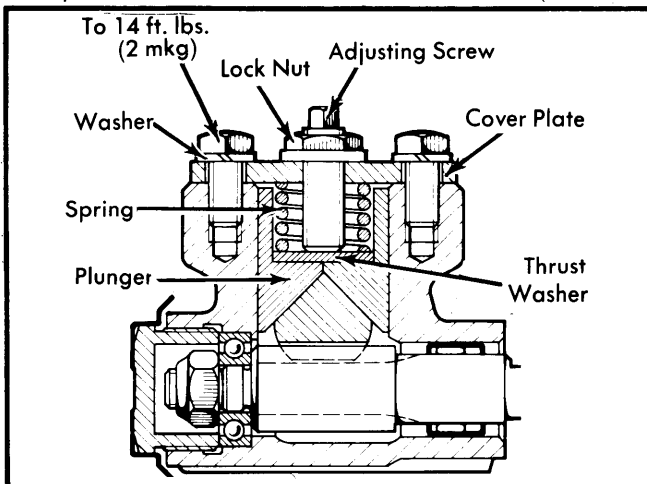

Fig. 1 Sectional View of Adjustable Steering Gear

Installation - Reverse removal procedure and torque nuts and bolts to specifications.

NOTE - Gain access to adjusting screw on Dasher by removing cover on access hole located in spare wheel well.

ADJUSTMENT

With components installed on vehicle, tighten adjusting screw by hand until screw just contacts thrust washer. Hold adjusting screw in position and tighten lock nut (Fig. 1).

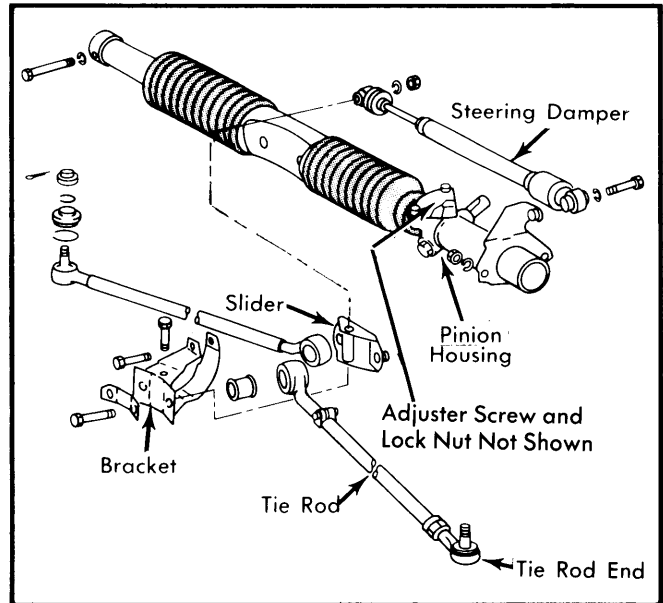

Fig. 2 Volkswagen Dasher Rack and Pinion Assembly (Type 1 Similar)

OVERHAUL

NOTE - Manufacturer does not recommend overhaul of this unit. If it is determined to be defective, replace as assembly.

TIGHTENING SPECIFICATIONS

| Application | Ft. Lbs. (mkg) |
|--|----------------|
| Gear Box-to-Brackets | |
| Type 1 | 18 (2.5) |
| Dasher | 14 (2.0) |
| Tie Rods-to-Rack | |
| All | 40 (5.5) |
| Universal Joint Clamp Pinch Bolts | |
| Type 1 | 18 (2.5) |
| Pinion Shaft Clamp Pinch Bolt | |
| Dasher | 22 (3.0) |