

## TRIUMPH RACK &amp; PINION

TR7  
Spitfire

## DESCRIPTION

Steering gear is a rack and pinion type with direct linkage (tie rods) to steering arms. Gear housings are mounted by bolts through frame on TR7; by "U" bolts on Spitfire models. A flexible coupling links the steering gears to steering shaft.

## ADJUSTMENTS

Rack and pinion free play are adjusted through the use of shims on the rack damper and pinion shaft. These adjustments are performed as part of overhaul procedure. See *Overhaul* below.

## REMOVAL &amp; INSTALLATION

## RACK AND PINION

**Removal** — 1) Raise vehicle and place on safety stands. Scribe an index mark on pinion shaft and lower steering coupling for installation purposes. Disconnect tie rod ends from steering knuckle.

2) Remove pinch bolt attaching lower steering coupling to rack pinion. On TR7 models only, withdraw bolts mounting pinion end of rack to chassis. On all other models, "U" bolts mount steering rack to chassis.

3) On TR7 only, remove remaining rack mounting hardware, disconnect lower pinion shaft coupling and take rack out driver's side. On all others, slide rack forward disengaging rack pinion splines from flexible coupling. Disconnect ground strap from rack plug and withdraw steering rack.

**Installation** — 1) If rack has been disassembled, it must be centralized before reinstallation: Remove center plug from thrust pad and, using a piece of welding rod, locate dimple in rack shaft. When dimple in rack shaft is aligned with plug hole rack is centralized.

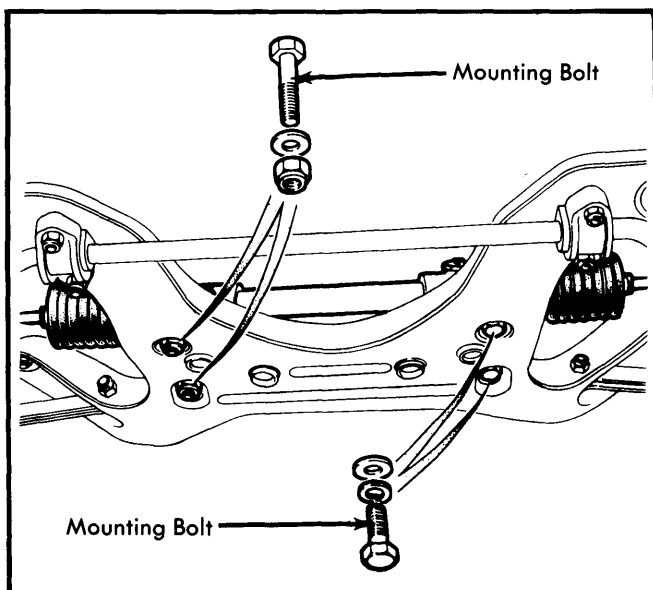

Fig. 1 Installed View of TR7 Rack Assembly

2) Carefully slide rack assembly into position but DO NOT disturb rack shaft. On TR7 models only, secure rack to chassis with mounting hardware, refit tie rod ends and tighten pinion coupling pinchbolt.

3) On all other models, hold steering wheel in straight-ahead position and engage rack pinion shaft splines in flexible coupling. Install and tighten pinch bolt. Keep rubber grommets correctly positioned on inboard side of rack flanges with lip under straight face of flange, then fit "U" bolts (Fig. 2). Refit tie rod outer ends to steering arms.

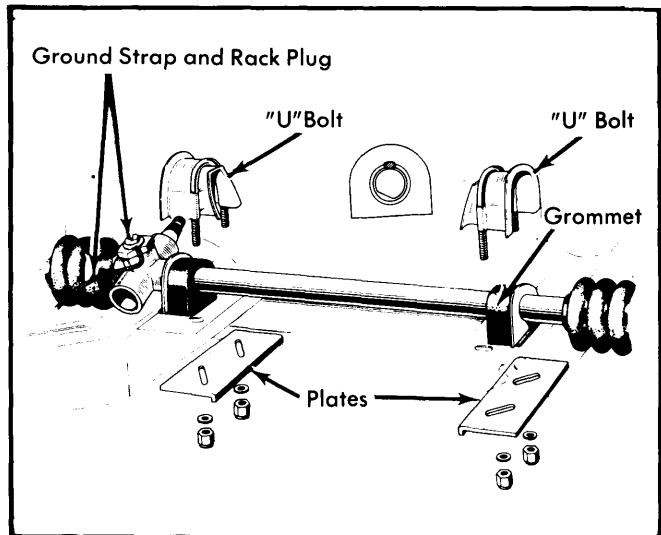

Fig. 2 Spitfire Rack with Rubber Grommets

4) Make sure all nuts and bolts are tightened and check front wheel alignment. See *Triumph* in WHEEL ALIGNMENT Section.

## OVERHAUL

## RACK AND PINION

**Disassembly** — 1) Release clip and slide bellows toward outer ball joint. Slacken inner lock nut and unscrew tie rod assembly from rack. Withdraw spring from rack end. Straighten tab washer, unscrew sleeve nut, and remove tab washer, shims, and cup.

2) Slacken outer lock nut and unscrew tie rod end from tie rod. Remove outer lock nut, bellows, and cup nut. Remove inner lock nut from rack. Repeat on other end.

3) Remove damper plug, spring, shims and damper. On Spitfire models, remove circlip from top of pinion and carefully pull out pinion, retainer, shims, bushing and thrust washer. Remove "O" ring from retainer. Be careful not to lose dowel pin. On TR7 models, remove rubber seal and pinion retaining plug then pull out pinion shaft and bearing. Remove circlip to slide bearing off pinion shaft.

4) Pull out rack and remove bushings from housing if necessary.

## TRIUMPH RACK & PINION (Cont.)

**Reassembly** — 1) Install end cover and lower bushing in rack housing (if removed). Place rack shaft in housing with teeth toward pinion end. Install lock nuts, tie rods, springs and shims, then tighten. Pack inner joints with grease, then install bellows and clips.

2) Rotate rack shaft until teeth mesh with pinion. On Spitfire models, install pinion. Replace thrust washer, bushing, shims, and retaining ring with new "O" ring. Fit circlip and check to see that end play does not exceed .010" (.254 mm). Adjust shim pack if necessary. See Fig. 3.

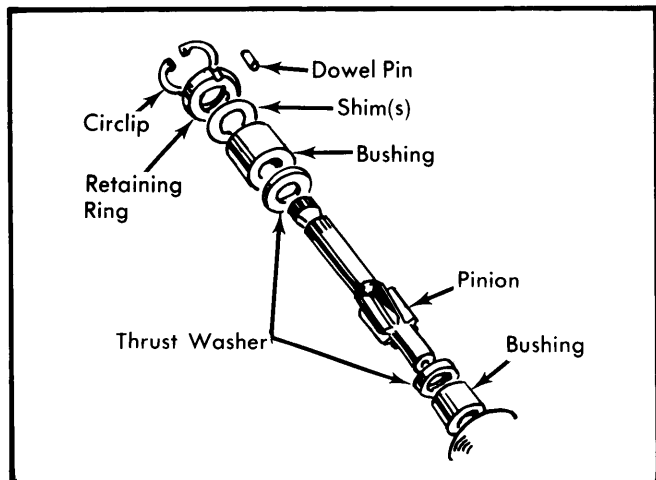

**Fig. 3 Exploded View of Spitfire Pinion Assembly**

3) On TR7 models, slide ball bearing on pinion and secure with circlip. Lubricate pinion shaft and insert into housing. Tighten end plug and replace rubber seal.

4) On all models, install rack damper, shims, spring and cap. Adjust rack side play by adding shims so movement does not exceed .004-.008" (.1-.2 mm) for Spitfire, or .001-.007" (.03-.18 mm) for TR7. Install rack in vehicle and reconnect ground strap (if removed).

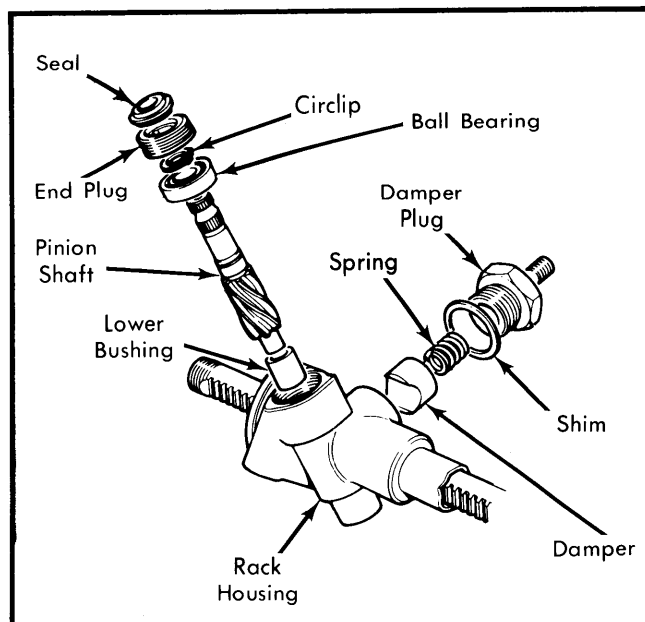

**Fig. 4 Exploded View of TR7 Pinion and Damper**

### TIGHTENING SPECIFICATIONS

Application	Ft. Lbs. (mkg)
Steering Gear-to-Frame	
TR7 .....	22-29 (3.0-4.0)
Spitfire .....	16 (2.2)
Tie Rod Lock Nuts	
TR7 .....	30-37 (4.1-5.1)
Spitfire .....	38 (5.2)
Universal Joint Pinch Bolts	
TR7 .....	16-21 (2.2-2.9)
Spitfire .....	14 (1.9)

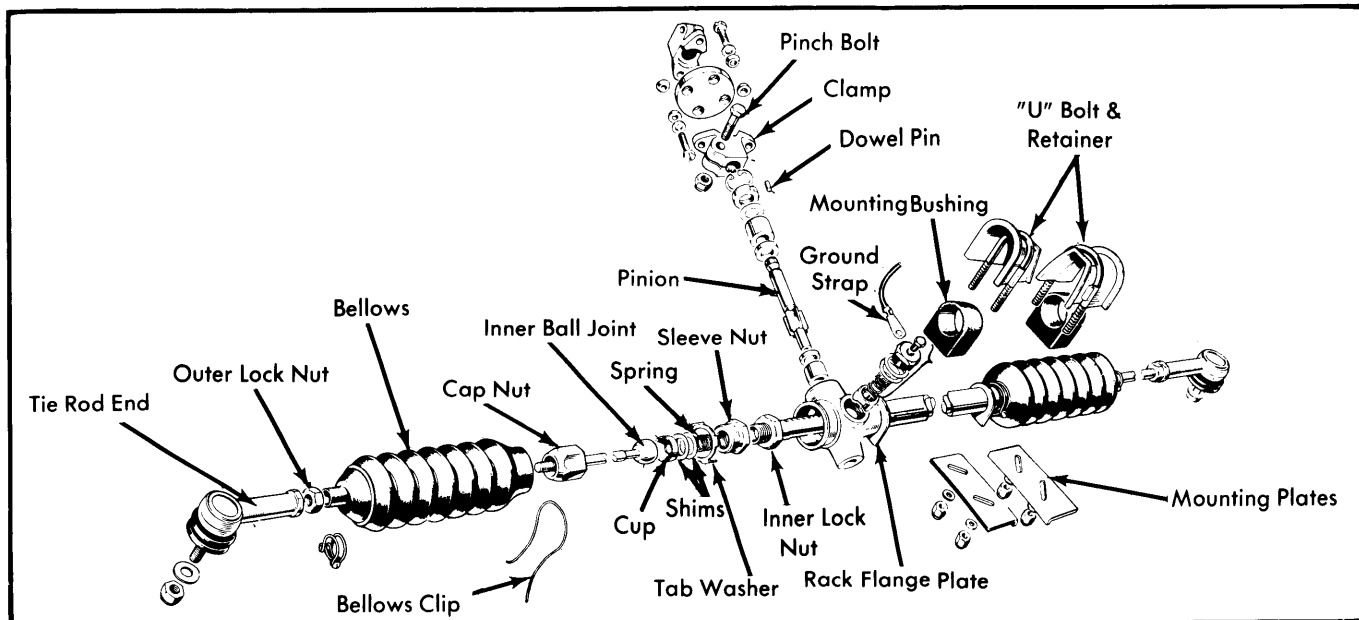

**Fig. 5 Triumph Spitfire Rack and Pinion Steering**