

Steering Gears & Linkage

TOYOTA LAND CRUISER RECIRCULATING BALL

FJ40
FJ55

DESCRIPTION

STEERING GEAR

Steering gear mechanism is of the recirculating ball type. Gear mounts off a bracket that is attached to frame. Adjustment screws are provided for backlash and preload. Initial preload is achieved with shims.

STEERING LINKAGE

Steering linkage consists of the following: pitman arm, relay rod, tie rod, damper, center arm and drag link. Tie rod and relay rod are adjustable to correct wheel alignment.

ADJUSTMENT

NOTE — Adjustments are done during reassembly after overhaul. For adjustments, refer to Overhaul in this article.

REMOVAL & INSTALLATION

STEERING GEAR

Removal — Scribe mating marks on all steering shaft couplings to aid in reassembly. Remove coupling clamp bolt. Remove steering wheel and snap ring at top of column, then pull main shaft back from steering gear. Remove steering gear mounting bolts and pitman arm using suitable puller. Remove gear from frame.

Installation — To install, reverse removal procedure and tighten all mounting bolts.

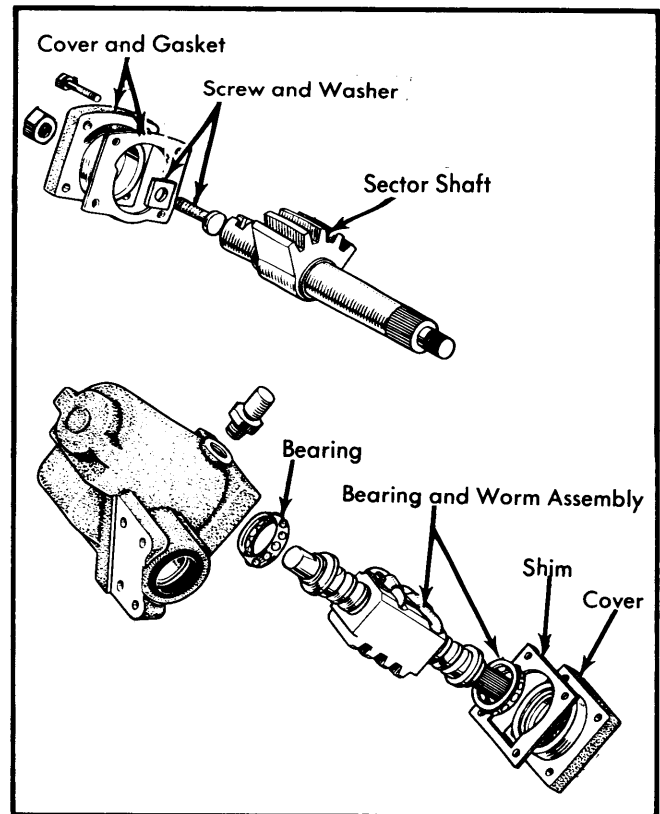

Fig. 1 Toyota Land Cruiser Steering Gear

STEERING LINKAGE

Removal — 1) — Raise and support front of vehicle, then remove front wheels. Index mark relative position of pitman arm to sector shaft and remove arm, using suitable puller. Disconnect steering drag link from steering center arm.

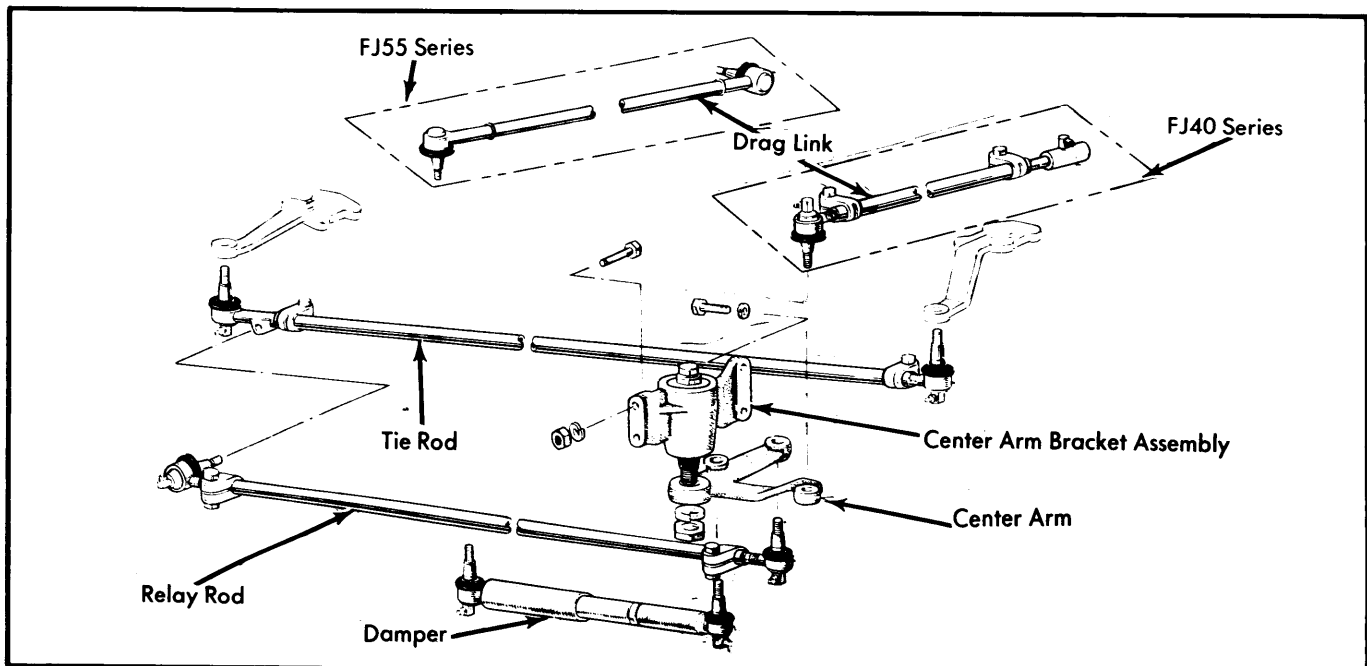

Fig. 2 Toyota Land Cruiser Front Steering Linkage with Detail of Both FJ40 and FJ55

TOYOTA LAND CRUISER RECIRCULATING BALL (Cont.)

2) Disconnect tie rod ends from both sides. Disconnect relay rod from steering center arm, then remove tie rod assembly with relay arm assembly. Disconnect end of steering damper from bracket on crossmember. Loosen and remove center arm from bracket (with steering damper). Remove steering center arm bracket from frame.

Installation – To install, reverse removal procedure and note the following: Adjust tie rod and relay rod as shown in Fig. 3.

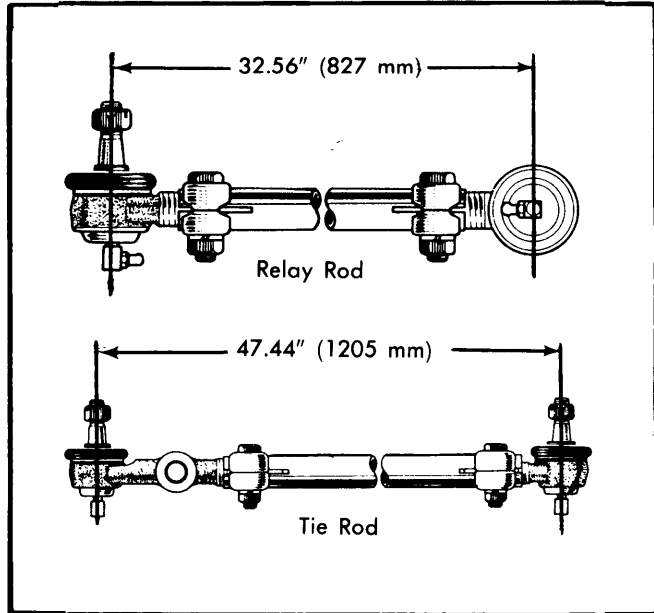

Fig. 3 Relay Rod and Tie Rod Length Adjustments for Installation

OVERHAUL

Disassembly – Drain gear lubricant, then secure housing in a vise. Remove sector shaft end cover and gasket. With sector shaft positioned at rotational center, pull assembly out of gear housing. Note number and placement of shims as they are removed. Remove gear housing end cover and gasket. Take out worm assembly, keeping bearings in sequence and don't attempt to disassemble worm assembly.

Inspection – Wash all disassembled parts and inspect for wear or damage; replace as necessary. If inner or outer races are scored or pitted, replace as required. Inspect sector shaft and bushings for wear. If replacement is necessary, use a press to remove and replace bushings. Hone bushings until clearance between bushing and sector shaft is .0004-.0024" (.009-.060 mm). Install new oil seal. Measure sector shaft thrust clearance, then select thrust washer that provides minimum clearance between sector shaft and adjustment screw: .004" (.1 mm).

Reassembly – 1) Install cover with same number of shims that were removed, then tighten bolts. **NOTE** – When tightening cover bolts keep checking worm to see that it will turn properly.

2) Using a pull scale, measure initial (starting) worm bearing preload for 8.8-13.2 lbs (4-6 kg). If preload is not within specifications, correct by selecting proper thickness shim(s).

3) Position worm ball nut at center, then insert sector shaft ensuring ball nut and sector mesh together at center. Loosen ball adjusting bolt all the way and install cover.

4) Set worm shaft preload to 17.6-24.2 lbs. (8-11 kg) with adjusting bolt. Make sure measurement is made with meshing positioned at center.

5) Install pitman arm and check backlash. There should be zero backlash when worm is rotated within 45° to either side. Tighten adjustment screw lock nut and recheck preload.

TIGHTENING SPECIFICATIONS

Application	Ft. Lbs. (mkg)
Sector End Cover Bolts.....	21.7-32.5 (3.0-4.5)
Worm Bearing Cap.....	21.7-32.5 (3.0-4.5)
Gear Box Bracket	28.9-39.8 (4.0-5.5)
Pitman Arm Nut.....	119-141 (16.5-19.5)