

# Steering Gears & Linkage

## HONDA RACK & PINION

Civic  
Civic CVCC  
Accord

### ADJUSTMENT

**NOTE** — Rack piston must be adjusted whenever steering gear assembly is removed and installed.

Make sure gear is well lubricated. Loosen rack piston adjusting screw lock nut. Tighten adjusting screw until lightly bottomed. Back off screw 45° and hold in that position while tightening lock nut. Recheck play. Move front wheels from lock-to-lock to make sure rack moves freely. Recheck steering force.

### REMOVAL & INSTALLATION

#### STEERING GEAR

**Removal** — 1) Raise front of vehicle and support with safety stands. Remove front wheels. Attach suitable engine hoist (07966-634011) to torque rod bolt and to bolt just left of distributor, and lift engine far enough to take load off engine mounts.

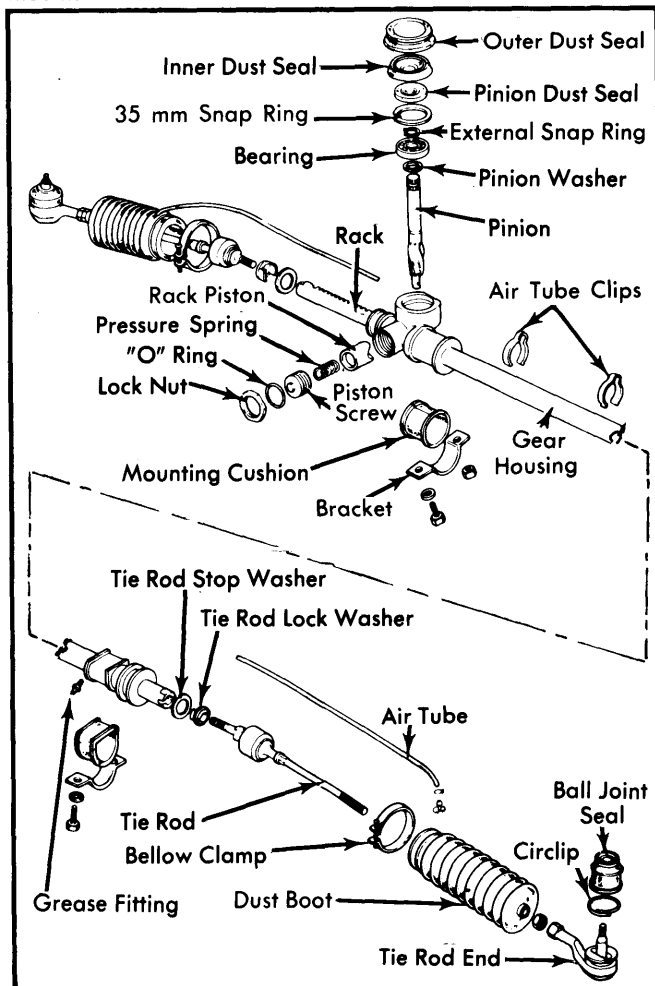

Fig. 1 Exploded View of Honda Rack & Pinion Steering Gear Assembly

2) Remove tie rod ends from steering knuckles. Disconnect linkage at engine on standard transmissions or the control cable at transmission on automatic transmissions. Disconnect exhaust pipe at manifold. Make sure engine is properly supported and remove center support member.

3) Turn steering wheel to a full lock position and remove steering shaft universal joint from pinion shaft. Unscrew steering gear retaining bolts. Bend left tie rod upward and lower rack until pinion shaft clears vehicle body. Rotate steering gear assembly until pinion shaft is facing down. Move rack toward one side until tie rod can be lowered out bottom. Remove gear assembly through bottom of subframe.

4) On Accord models, turn steering wheel to full left lock position. Remove steering shaft connector bolt and washer, then remove steering gear box mounting bracket. Move gear-box as far right as possible, disconnect left end and remove assembly from vehicle.

**Installation** — To install, reverse removal procedure.

### OVERHAUL

#### STEERING GEAR

**Disassembly** — 1) Disconnect air tube at tie rod dust seal clamps and move rubber boots to expose tie rod and rack joints. Straighten tie rod lock washer tabs. Remove both tie rods.

2) Remove rack screw lock nut, rack piston screw, pressure spring, and piston. Rack piston can be removed with snap ring pliers, if necessary. Remove pinion dust seal by carefully prying around pinion shaft. **CAUTION** — Do not pry at outer edge, as housing will be damaged.

**Inspection** — Check all components for wear and replace as necessary. Measure rack piston length. New spring should be 1.028" (26.1 mm) and used spring should be .945" (24 mm) for Accord and 1.087" (27.6 mm) new, .984" (25 mm) used for all others. Replace if necessary.

**Assembly** — Before assembling, coat each sliding component with grease, then reverse disassembly procedure, noting the following: First install steering rack to gear box. Install pinion in place and mesh it with rack. Position internal snap ring and then a new pinion dust seal. Install rack guide in proper position (note contour of guide over rack). Position pressure spring, new "O" ring on guide screw, and install screw. Adjust rack guide screw as described under Adjustment.

### TIGHTENING SPECIFICATIONS

| Application                         | Ft. Lbs. (mkg)  |
|-------------------------------------|-----------------|
| Mounting Bracket (CVCC Only)        |                 |
| Pinion Shaft Side .....             | 16 (2.2)        |
| Tube Side .....                     | 22 (3.0)        |
| Mounting Bracket (Accord and Civic) |                 |
| Both Sides .....                    | 14-18 (1.9-2.5) |
| Rack Piston Lock Nut .....          | 33 (4.5)        |
| Tie Rod Lock Nut .....              | 33 (4.5)        |
| Tie Rod-to-Steering Knuckle .....   | 25 (3.5)        |
| Universal Joint Clamp Bolt .....    | 17-22 (2.5-3.0) |