

## FIAT 131 RACK & PINION

131

### DESCRIPTION

Rack and pinion type steering gear is mounted in rubber insulators and attached to frame. Gear is attached to steering shaft through universal joints. Adjustment is provided for pinion bearing preload. At each end of steering rack, tie rods connect steering mechanism to front wheels.

### ADJUSTMENT

**NOTE** — Adjustments of the pinion bearing preload are performed during overhaul. See Overhaul procedure.

### REMOVAL & INSTALLATION

#### STEERING GEAR

**Removal** — With wheels in straight ahead position, disconnect tie rod ball joints from steering knuckles. Disconnect steering column universal joint from pinion shaft. Remove bolts securing steering gear assembly to frame and remove steering gear from vehicle.

**Installation** — Make sure steering wheel is in center position, wheels are straight ahead and pinion gear is centered. Install steering gear assembly to frame. Connect steering column universal joint to pinion shaft and tie rod ball joints to steering knuckles. Check wheel alignment. See *Fiat* in WHEEL ALIGNMENT section.

### OVERHAUL

**Disassembly** — 1) Loosen clamps securing dust boots to tie rod and gear housing. Slide boots onto the tie rod and position gear assembly into vise so that rack is securely clamped. Remove one tie rod inner ball joint from rack.

**NOTE** — Ball joints are staked to rack, do not remove other ball joint unless replacement is necessary.

2) Remove rack piston retainer plate, plug, spring, and rack piston. Slide rack out of gear housing. Remove pinion shaft and bearing.

**Assembly & Adjustment** — 1) Inspect bearing on pinion shaft and in housing. Replace if necessary.

2) Slide rack into gear housing. Install pinion and bearing. Tighten pinion nut to specification. Check pinion shaft torque with rack installed. Effort required to turn pinion should not exceed 4 ft. lbs. (.5 mkg). With torque correct, stake pinion nut in place.

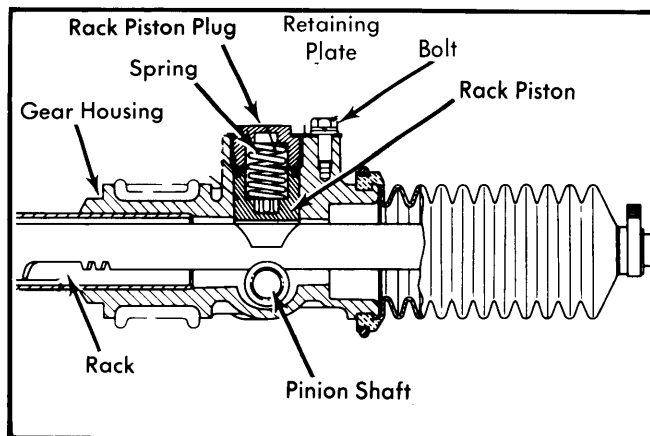

Fig. 1 Sectional View of Rack Piston Assembly

3) Center rack in gear assembly. Install rack piston, spring, plug and retainer. With dust boots on tie rods, lubricate tie rod inner ball joint with oil and install on rack. Tighten ball joint collar to specification, then stake to rack.

4) Slide one dust boot onto gear housing and secure to gear housing and tie rod with clamps. Stand steering gear assembly on end and pour 5-5.2 oz. (145-155 cc) of oil (SAE 90 EP) into gear housing. Install other dust boot.

**NOTE** — Lubricate dust boots with a silicone spray and be sure they are not twisted after installation.

### TIGHTENING SPECIFICATIONS

Application	Ft. Lbs. (mkg)
Pinion Shaft Nut .....	22-23 (3-3.2)
Tie Rod Inner Ball Joint .....	11 (1.5)

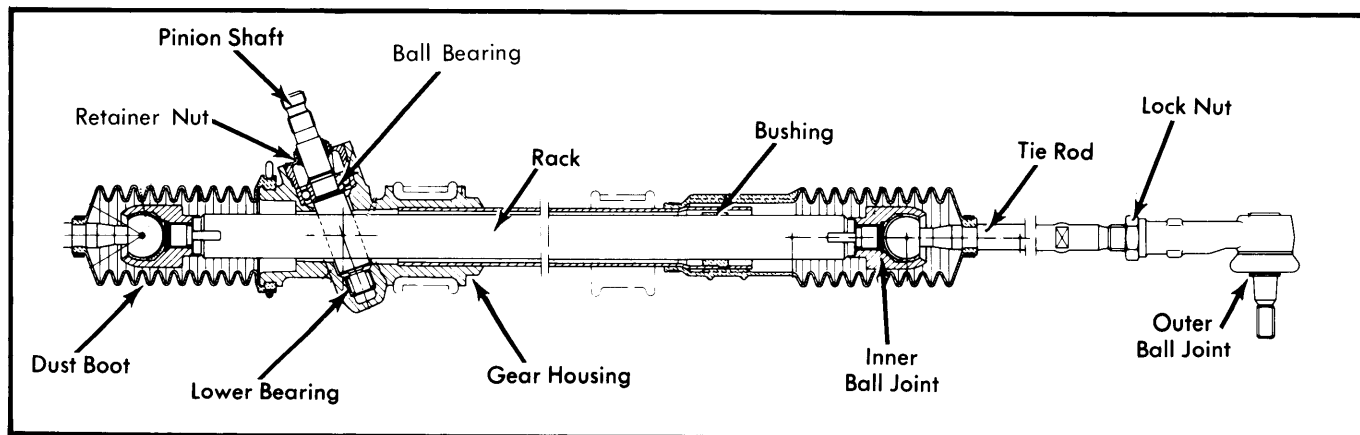

Fig. 2 Sectional View of Rack & Pinion Steering Gear Assembly