

Steering Gears & Linkage

FIAT X1/9 & 128 RACK & PINION

X1/9
128

DESCRIPTION

Rack and pinion type steering gear is mounted in rubber insulators and attached to body. Gear is attached to steering shaft through universal joints. Adjustments are provided for pinion bearing play and rack yoke free play. At each end of steering rack, tie rods connect steering mechanism to front wheels.

ADJUSTMENT

NOTE — Adjustments of the pinion bearing and rack yoke are performed during rebuilding. See Overhaul procedure.

REMOVAL & INSTALLATION

STEERING GEAR

Removal — 1) Disconnect battery leads. Raise and support front end of vehicle, then remove front wheels. On 128 models it may be necessary to remove the spare tire. Remove three screws holding gasket cover to steering box (at toe board).

2) Disconnect drive pinion from lower steering column section by detaching universal joint inside vehicle. Using a suitable puller (A. 47035), remove tie rods from steering knuckles.

3) Remove stone shield, then unbolt and remove steering gear assembly by sliding out from right hand side of vehicle.

Installation — Fill gear with suitable oil before inserting into vehicle. Set front wheels in straight-ahead position, then connect drive pinion to steering column. Remount gear to body. Connect tie rods to steering knuckles and torque attaching nuts to 58 ft. lbs. Replace stone shield and front wheels.

OVERHAUL

Disassembly — 1) Disconnect tie rods from ball joints (inner end of tie rods). Loosen rubber dust boot retaining clamps, then drain oil from gear. Remove dust boots, then brackets and rubber cushions attaching gear to body.

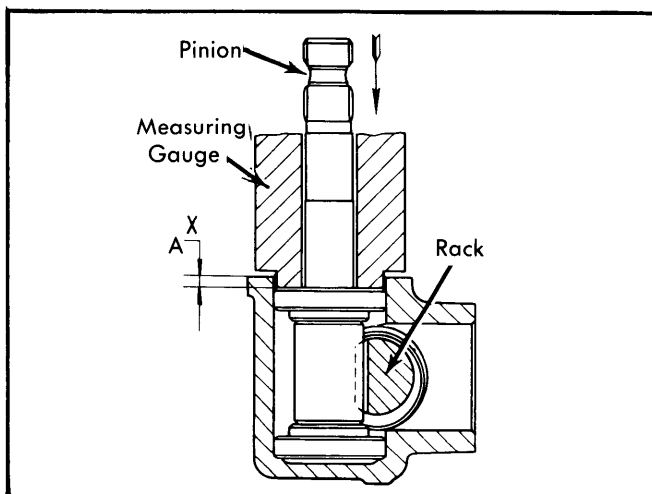

Fig. 1 View Showing Measurement "A" for Pinion Bearing Shim Thickness

2) Detach rack yoke cover plate and withdraw gasket, spring, shims, and yoke. Remove pinion cover plate and withdraw gasket, shims, and drive pinion (with upper ball bearing).

3) Mount steering gear in vise, unscrew ball joint ring nuts, then slide off joints with sockets and springs. Slide rack out of steering box, then remove lower drive pinion bearing.

Assembly & Adjustment — 1) Set steering box in horizontal position in padded vise, with pinion flange on top. Insert lower pinion bearing, using a suitable driver (A. 74219). Replace bushing in steering box. Slide rack into position with smooth side facing pinion seating. When rack is fully in place, turn teeth to face axis of pinion seating.

2) Insert pinion, ensuring it mates properly with rack teeth, then install upper pinion bearing. Apply force to pinion to eliminate axial play, then with a suitable measuring device, measure distance "A" as shown in illustration. To this measurement, add .001-.005" (.025-.13 mm). This will give the total shim thickness to be used. Remove tool, install shim, cover plate, and oil seal. Check turning torque of pinion. It should be .3 ft. lb. (.04 mkg) or less.

3) Set rack to center position, insert rack damper yoke in its seat, install cover plate (without shims) and turn pinion 180° in both directions to settle rack and yoke. Measure gap between rack yoke cover plate and mounting surface ("B" as shown in illustration). To this measurement, add .002-.005" (.05-.13 mm). This will give total shim thickness to be used. Remove cover, insert spring, "O" ring, shim (coated with liquid adhesive), and cover. Tighten bolts as required. Ensure ground wire is in place.

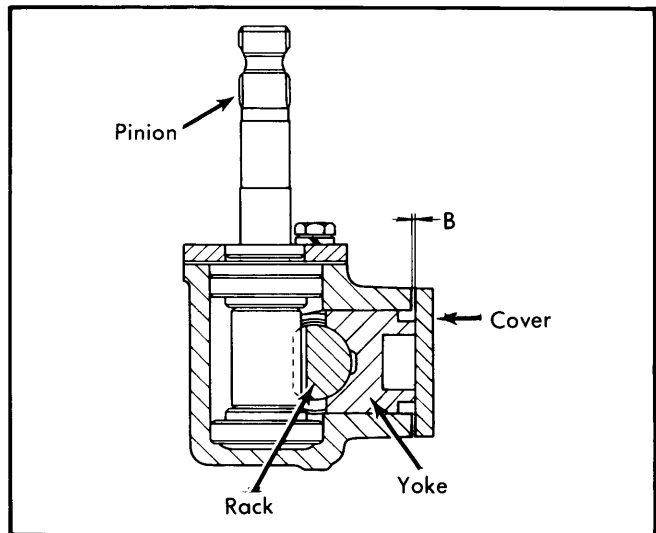

Fig. 2 View Showing Measurement "B" for Rack Yoke Shim Thickness

4) Screw ball joint ring nuts onto rack to end of threaded portion. Assemble springs and socket. Lubricate ball pins with suitable oil, and assemble to rack. Install adjustable ball joint heads and tighten until a force of 1.5-3.75 ft. lbs. (.2-.5 mkg) is required to turn the pins. Lock heads in position with nuts, then stake-lock the nut collars and ball heads. Replace rubber dust boots and clamp in place. Ensure clamp screws are positioned such that they will be accessible when gear assembly is installed in vehicle. Fill gear with 4.75 oz. (140 cc) of suitable gear oil.

NOTE — Lubricate dust boots with a silicone spray and be sure they are not twisted after installation.