

DATSUN PICKUP RECIRCULATING BALL

Pickup

DESCRIPTION

The steering system is comprised of a recirculating ball type steering gear and a relay design steering linkage. The linkage connects the pitman arm to one end of an adjustable center link. The other end of the center link is connected to the idler arm assembly. Two nonadjustable tie rods connect both ends of the steering linkage to the steering knuckles.

REMOVAL & INSTALLATION

STEERING GEAR

Removal — 1) Disconnect battery ground cable. Remove steering wheel, upper and lower column shell covers, and turn signal switch assembly. Unscrew two retaining bolts at column support clamp under instrument panel. Remove screws holding column grommet to dash panel.

2) Unscrew pitman arm retaining nut, scribe a mark for arm-to-sector shaft position and detach pitman arm. Remove three bolts securing gear housing to frame. Withdraw steering gear.

Installation — To install, reverse removal procedure, noting the following: Align pitman arm-to-sector shaft scribe marks after first setting front wheels and steering wheels in straight-ahead position.

STEERING LINKAGE

Removal — 1) Jack up front of vehicle and support on stands. Remove cotter pins and nuts retaining outer tie rod end to steering knuckles. Separate knuckles from rod ends. Detach idler arm and pitman arm from cross shaft. Remove cross shaft and tie rod assembly from vehicle.

2) Unbolt idler assembly from vehicle. Disconnect both tie rods from cross shaft. Remove idler arm nut and disassemble idler unit.

Installation — Reassemble and install steering linkage in reverse of removal procedure, noting the following: Installed length of center link (as measured from center-to-center of ball studs) should be 20.7" (516 mm). Adjust toe-in and steering angle. See *Datsun* in **WHEEL ALIGNMENT** section.

ADJUSTMENT

NOTE — Adjustments are performed as part of reassembly procedure. See *Overhaul* as outlined below.

OVERHAUL

STEERING GEAR

Disassembly — 1) Drain steering gear of oil, then place assembly in padded vise. Loosen lock nut and turn sector shaft adjusting screw a few turns counterclockwise. Remove sector shaft cover bolts. Now turn adjusting screw clockwise until cover is free, then pull sector shaft and cover from gear housing. Separate sector shaft, adjusting screw, and shim from cover.

2) Unscrew column tube retaining screws and remove tube. Withdraw worm assembly from housing. Detach worm bearings and adjusting shims from assembly and column tube.

CAUTION — Do not allow ball nut to run freely to either end of travel on worm or ball guides may be damaged.

3) Pry out sector shaft oil seal from housing (discard seal). Remove "O" ring from rear cover and column tube (discard "O" ring). Remove column tube bushing.

NOTE — Do not remove sector shaft bushing from housing. If bushing is defective, replace entire worm gear assembly.

NOTE — Do not disassemble ball nut. If found to be defective, replace entire worm gear assembly.

Assembly & Adjustment — 1) Fit column tube bushing into position (coated with suitable adhesive on exterior of bushing and grease on interior). Fill space of new sector shaft oil seal lips with grease, then install seal. Place worm assembly, with bearings, into housing. Install column tube with new "O" ring and original amount of column tube shims.

NOTE — Be sure thicker shim is to gear housing side.

2) Adjust worm bearing preload by selecting suitable bearing shims so that initial turning torque of steering column shaft is 2-4 INCH lbs. (2.4-4.4 cmkg) when measured at steering shaft, and 5-8 oz. (.12-.22 kg) when measured with pull scale at steering wheel circumference. **NOTE** — Measurements given are with original bearings installed. If new bearings are used on the worm, the values should be 3.5-5 INCH lbs. (4-6 cmkg) and 6.6-11 oz. (.4-.7 kg) respectively.

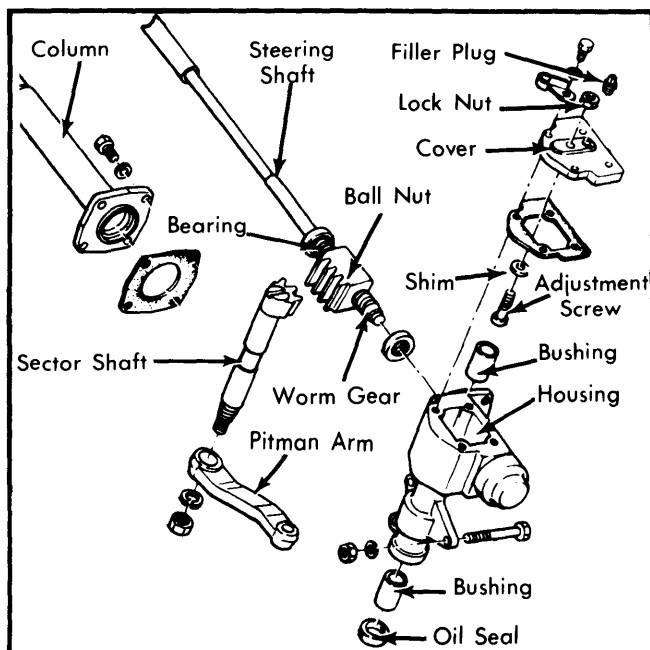

Fig. 1 Exploded View of Recirculating Ball Steering Gear Assembly

Steering Gears & Linkage

DATSUN PICKUP RECIRCULATING BALL (Cont.)

3) Install adjusting screw into "T" groove at sector shaft head. Choose suitable shim for placement beneath adjusting screw which will give an end play of .0004-.0012" (.01-.03 mm) at adjusting screw.

4) Rotate ball nut by hand until it is in center of its travel, then install sector shaft, engaging center sector tooth with center of ball nut. Coat sector cover packing faces with sealant, then install cover. Turn adjusting screw counterclockwise to bring cover into mounting position. Temporarily install cover bolts.

5) Turn adjusting screw an additional amount to bring sector shaft toward cover approximately .08-.12" (2-3 mm). Fully tighten sector cover bolts. Now gradually turn adjusting screw clockwise to push sector shaft against ball nut. When a light mesh is felt, secure lock nut.

6) Install pitman arm to sector shaft and move arm several times side to side to ensure smooth movement. Adjust backlash

at neutral position of pitman arm by turning adjusting screw in or out until less than .004" (.1 mm) free play is measured at outer end of arm.

7) Turn adjusting screw approximately 1/8 - 1/6 turn clockwise and retighten lock nut. Fill gear housing with suitable oil (3/4 pt.).

TIGHTENING SPECIFICATIONS

Application	Ft. Lbs. (mkg)
Column Tube-to-Gear	11-18 (1.52-2.49)
Sector Shaft Cover	11-18 (1.52-2.49)
Adjusting Screw Lock Nut	22-29 (3.04-4.01)
Gear-to-Frame	33-38 (4.56-5.25)
Steering Wheel Nut	51-54 (7.05-7.47)
Pitman Arm-to-Gear	94-108 (13.0-14.9)
Steering Linkage Connections	40-72 (5.53-9.95)

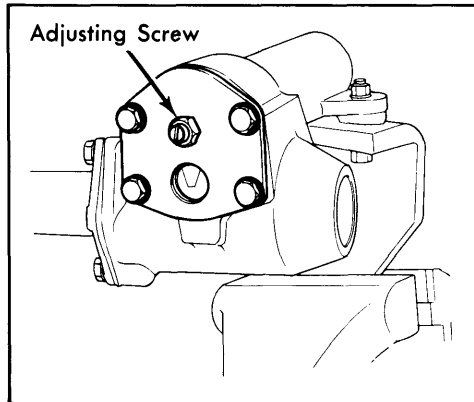

Fig. 2 Removing Sector Shaft Cover

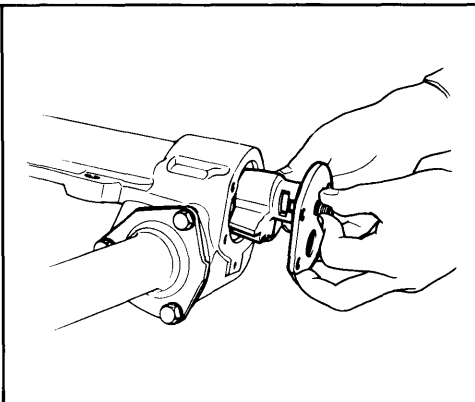

Fig. 3 Removing Sector Shaft

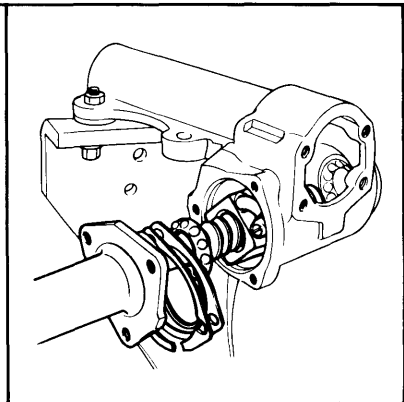

Fig. 4 Removing Steering Gear Worm