

## DATSUN F10 RACK & PINION

F10

### DESCRIPTION

Steering assembly is a direct-acting rack and pinion system with a gear ratio of 18.0:1. This unit consists of a rack bar and toothed pinion. Backlash is held to zero by the retainer and the retainer spring.

### REMOVAL & INSTALLATION

**Removal** — 1) Raise and support front of vehicle; remove front wheels. Remove cotter pins and nuts from tie rods, then pull tie rods from steering knuckle. Loosen bolt securing lower joint assembly to pinion, then remove bolt from lower joint assembly.

2) Remove bolts securing steering gear housing to front member, then remove steering gear and linkage by pulling them out to the side.

**Installation** — Install in reverse order of removal procedure noting the following: Be sure to align bracket with gear housing mounting correctly and check that black clip is installed on gear housing and white clip is on rubber mount.

### ADJUSTMENT

**NOTE** — Adjustments are performed during gear assembly. See Overhaul as outlined.

### OVERHAUL

**Disassembly** — 1) Clamp rack and pinion assembly in a vise, using pads on steering gear housing to prevent damage. Remove boot clamps, then loosen tie rod lock nut and inner

socket assembly. **NOTE** — Do not disassemble inner socket assembly or tie rod assembly. Remove tie rod assembly from rack.

2) Loosen rack adjuster lock nut (on housing), then remove adjuster, spring, and rack damper. Remove oil seal from pinion shaft, then pry snap ring from pinion housing and withdraw pinion assembly. Pull rack from gear housing.

3) Remove snap ring securing pinion bearing, then press out bearing from pinion shaft. Remove rubber mounts by striking with wood hammer. Pry snap ring from steering gear housing and remove rack bushing.

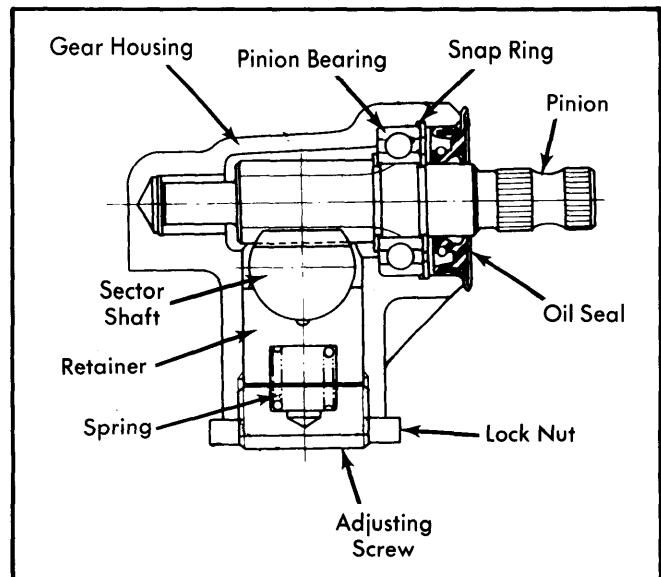

Fig. 2 Cutaway View of Steering Gear

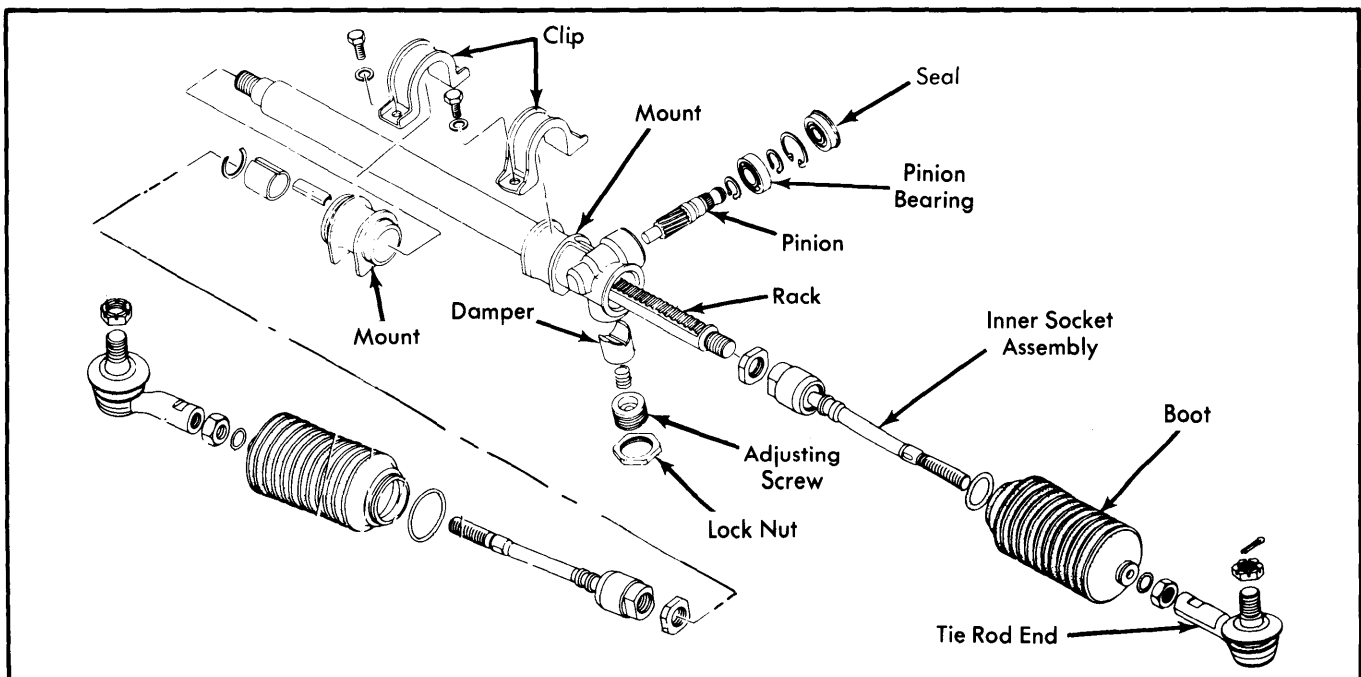

Fig. 1 Exploded View of Rack & Pinion Steering Gear Assembly

# Steering Gears & Linkage

## DATSUN F10 RACK & PINION (Cont.)

**Assembly & Adjustment** – 1) Press bearing onto pinion gear, then install .047-.049" (1.119-1.24 mm) snap ring in shaft ring groove (inner side of bearing). Install snap ring of proper thickness in shaft ring groove (outer side of bearing), to limit bearing end play to .0039" (0.1 mm). Snap rings are available in the following thicknesses: .041-.043" (1.04-1.09 mm), .043-.045" (1.09-1.14 mm), .045-.047" (1.14-1.19 mm), .047-.049" (1.19-1.24 mm), and .049-.051" (1.24-1.29 mm).

2) Drive rack bushing into tube and secure with snap ring. Install rubber mount with plate onto tube, making sure that cut-out section in mount is aligned with hole in tube and ventilation hole is not clogged.

3) With gear clamped in vise, thinly coat rack teeth and sliding surfaces with multi-purpose grease and install rack into tube from gear housing side. Coat pinion teeth and bearing with multi-purpose grease, then mesh pinion with rack and insert pinion assembly into housing.

4) Secure bearing in housing with a snap ring of proper thickness to take up clearance. Snap rings are available in the following thicknesses: .067-.069" (1.70-1.75 mm), .065-.067" (1.65-1.70 mm), .063-.065" (1.60-1.65 mm), and .061-.063" (1.55-1.60 mm).

5) Press oil seal into housing, then pack sealing lips with grease. Check that pinion assembly rotates smoothly.

6) Check pinion for minimal end play using a dial gauge. Play must not exceed .012" (.3 mm). If it does, recheck gear, rack teeth, and adjusting snap rings.

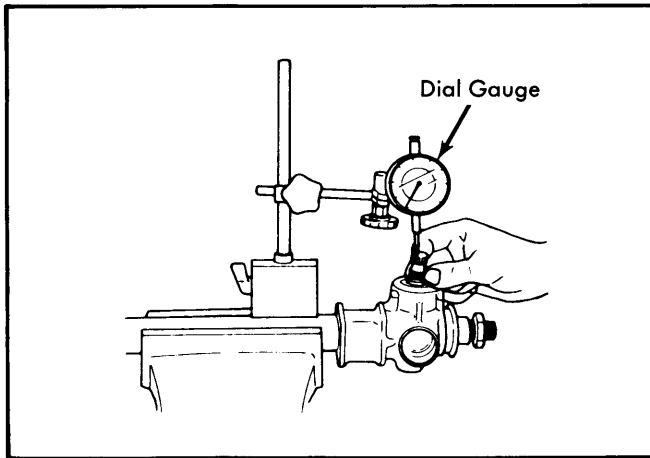

**Fig. 3 Measuring Pinion Axial Play**

7) Grease rack damper, then insert damper and spring into housing. Screw in adjuster and install lock nut. Turn in adjuster until damper is tight, then back off adjuster approximately 20 to 25 degrees. Apply suitable sealant on adjuster threads and tighten lock nut.

8) After gear assembly is complete, check pinion rotary torque and force required to move rack. Pinion torque should be 0-17 INCH lbs. (0-20 cmkg) and rack pull force should be 33-66 lbs. (15-30 kg). If steering gear does not meet specifications, readjust rack damper adjuster.

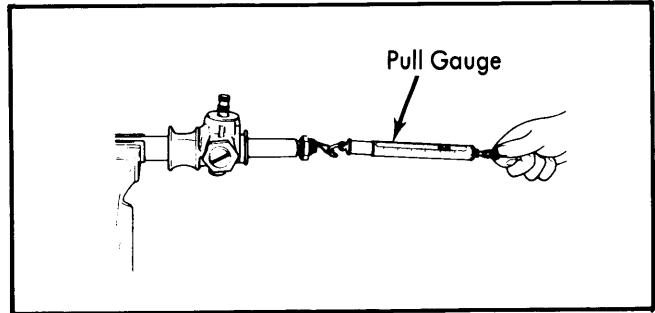

**Fig. 4 Measuring Rack Pulling Force**

9) Install boot to inner socket assembly, then connect socket assembly to tie rod socket and tighten lock nut temporarily. Screw in inner socket as far as it will go. Apply locking agent to threaded part of lock nut and tighten to specification.

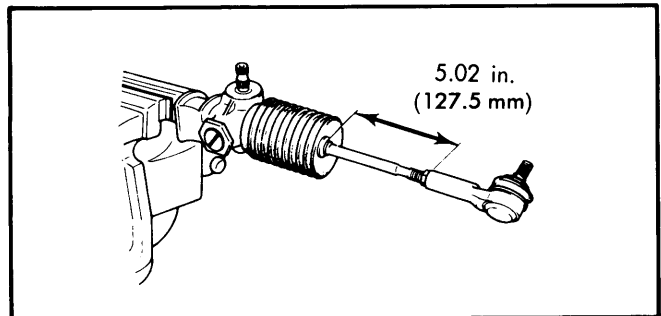

**Fig. 5 Tie Rod Length Adjustment**

10) Install boot and clamp on tie rod assembly, then measure swinging torque and axial play of inner socket assembly. Swinging torque should be 1.1-5.4 ft. lbs. (.15-.75 kg). Axial play should be zero.

11) Install boots to gear housing and rubber mount. Adjust tie rod length at each side to 5.02" (127.5 mm) and tighten lock nut to specifications.

### TIGHTENING SPECIFICATIONS

Application	Ft. Lbs. (mkg)
Steering Wheel Nut .....	20-25 (3.0-3.5)
Column Clamp Bolt .....	6.5-10 (.9-1.4)
Upper "U" Joint Shaft-to-Column Bolt .....	14-17 (1.9-2.4)
Lower "U" Joint Shaft-to-Column Bolt .....	14-17 (1.9-2.4)
Tie Rod Stud-to-Steering Knuckle Nuts .....	40-47 (5.5-6.5)
Inner Socket Lock Nut .....	58-72 (8-10)
Outer Socket Lock Nut .....	27-34 (3.8-4.7)
Gear Housing Clamp Bolt .....	16-25 (2.2-3.4)
Adjuster Lock Nut .....	29-43 (4-6)