

VOLVO

240 Series
260 Series

DESCRIPTION

Steering column is divided in two sections. Upper and lower sections are joined by means of a flange. A heavy frontal impact would cause flange to break from upper column. The upper portion of steering column would retain its position, eliminating possibility of its being forced toward driver. Upper part of column is carried in two ball bearings located in jacket tube. Lower end of steering column is connected to steering shaft by a flange.

REMOVAL & INSTALLATION

STEERING COLUMN

Removal – 1) Disconnect battery ground. Remove steering wheel. See *Volvo* under **STEERING WHEEL & COLUMN SWITCHES** in this Section.

2) Work inside engine compartment and disconnect clamp holding column shaft to lower shaft universal joint. Pry clamp apart with screwdriver, do not tap with hammer.

3) Remove column covers. Disconnect wiring and remove turn signal and wiper switches. Remove switch retainer, spring, and bearing race.

4) Drill steering column lock bolts and remove with a screw extractor.

5) Slide out steering column rubber grommet at firewall. Remove steering column lower mounting bolts. Force steering column through firewall until clear of lower portion of instrument panel. Pull column toward passenger compartment and remove from vehicle.

6) Place steering column assembly in a soft jawed vise and remove steering lock mechanism.

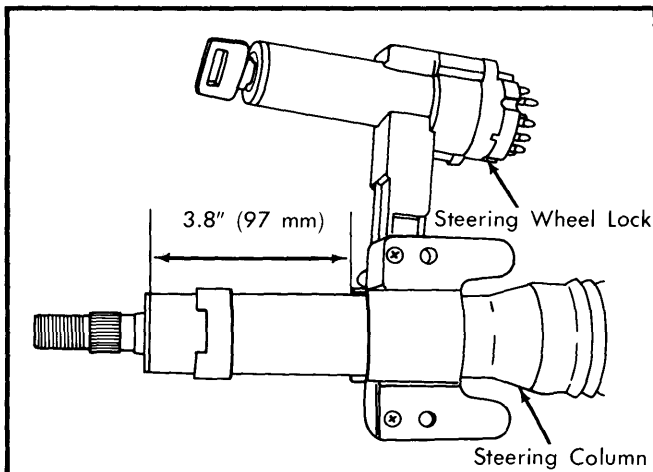

Fig. 1 Steering Wheel Lock Position

Installation – 1) Measure steering column to ensure length is 27.08-27.17" (688-690 mm). Position steering wheel lock on column so lock upper edge is 3.8" (97 mm) from upper edge of steering column. See Fig. 1.

2) Place rubber seal on column and insert column through firewall. Make sure both plastic guides are in position on the dashboard and install bolts loosely in upper and lower attachments.

3) Adjust column position. Steering wheel lock should protrude from dashboard .53-.65" (13.5-16.5 mm) when measured at key position "III" at the lock. Check for binding and rubbing, and adjust dashboard beam if necessary. Tighten lower bolts to 15-22 ft. lbs. (2-3 mkg).

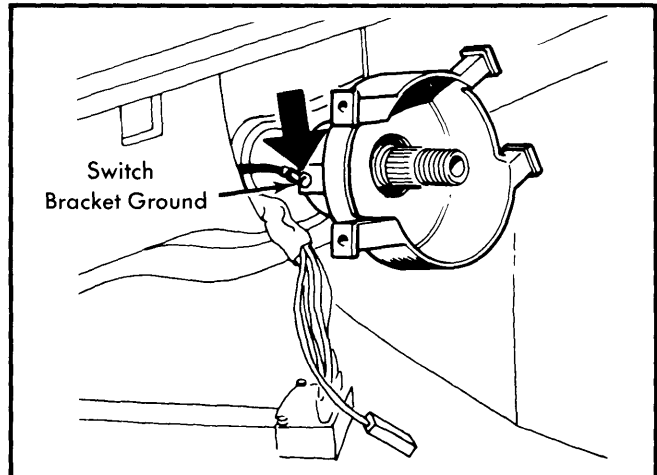

Fig. 2 Switch Bracket Ground on Steering Column

4) Install switch bracket. Make sure to use one of mounting screws as a ground. Install race and spring for upper race. Install turn signal, wiper switch and ignition switch. Connect horn wire lead.

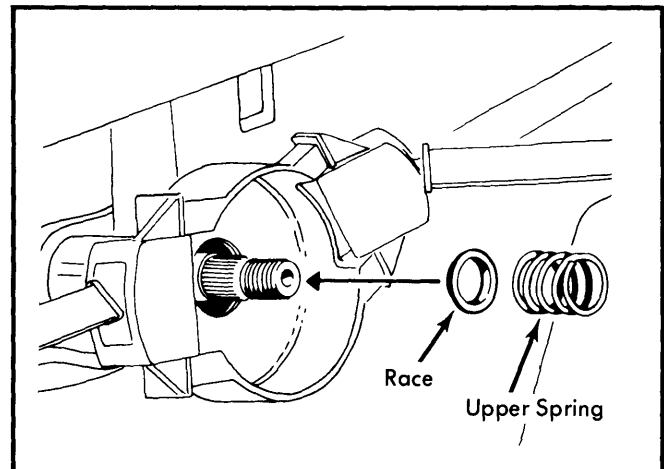

Fig. 3 Install Upper Bearing Race and Spring to Steering Column

5) Replace column covers after tightening upper bolts until the heads shear off. Install steering wheel and tighten nut to 33-55 ft. lbs. (4.6-7.6 mkg). Tighten lower column clamp bolt in engine compartment to 15-22 ft. lbs. (2-3 mkg).

NOTE – Rattling in steering column can be corrected by placing 1 or 2 flat washers between steering wheel and upper bearing spring.