

Steering Columns

TOYOTA COROLLA & CORONA

Corolla
Corona

DESCRIPTION

Columns used on Corolla and Corona models are collapsible two-piece design. Some models use plastic shear pins to absorb collision impact; other models have a collapsible bellows-type column. A flexible coupling connects the shaft to steering gear.

REMOVAL & INSTALLATION

STEERING COLUMN

Removal - 1) Working from inside engine compartment, remove bolt mounting steering mainshaft to steering gear box (Fig. 1). Before separating units, index mark for reinstallation and place front wheels in straight-ahead position.

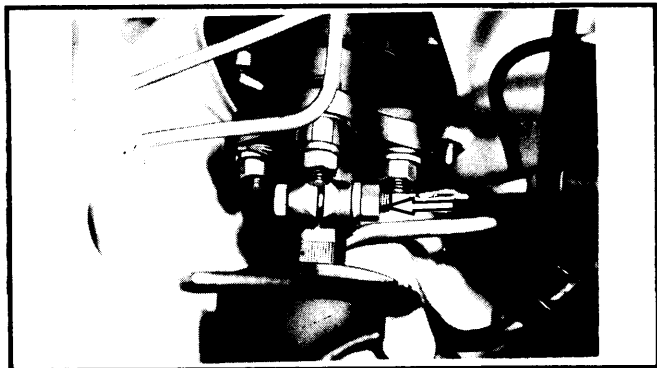

Fig. 1 Pinch Bolt Mounting Mainshaft to Steering Gear

2) Remove steering wheel and turn signal switch. See *Steering Wheel and Column Switch* in *STEERING* Section. From inside passenger compartment, remove bolts mounting hole cover to firewall. Remove nuts and bolts mounting the break-away bracket (Fig. 2) then withdraw steering column assembly into passenger compartment and free from vehicle.

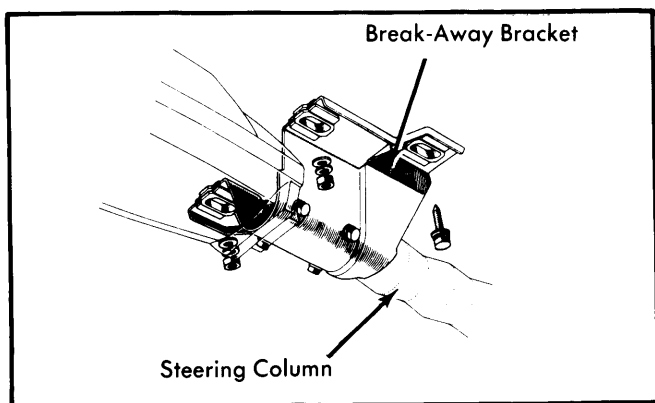

Fig. 2 Column Mounting Bracket (Corolla Shown, Corona Similar)

Installation - Working from inside passenger compartment, insert steering column assembly through column hole in firewall. Align index marks made during removal and tighten pinch bolt. Fit break-away bracket, but leave bolts finger tight. Position column hole cover in place with a new "O" ring seal. Push in column tube until fully seated, then tighten nuts mounting break-away bracket. Make sure hole cover locating pin contacts cover as shown in Fig. 3.

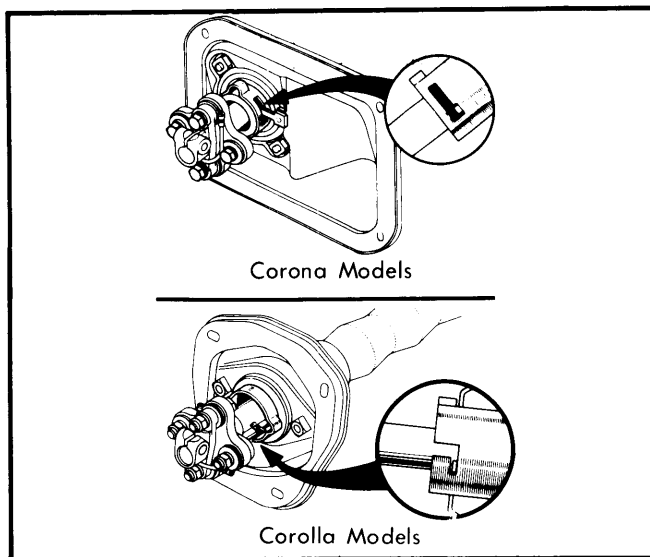

Fig. 3 Proper Installation of Steering Column Locating Pin

OVERHAUL

STEERING COLUMN

Disassembly - Remove upper steering column bracket. From column tube, pull out mainshaft, then remove dust seal. From lower end of mainshaft, remove flexible coupling unit. Remove bolts attaching column plate, rotate column tube counterclockwise and remove it from column hole cover.

Inspection - Check mainshaft for out-of-alignment and looseness in plastic pin. Inspect column tube for deformation. Look closely at flexible coupling for deterioration, also check dust seal "O" ring for damage.

Reassembly - To reassemble components, reverse disassembly procedure and note the following: Apply a light coat of grease to both sides of "O" ring.

TIGHTENING SPECIFICATIONS

Application	Ft. Lbs. (mkg)
Steering Gear-to-Frame.....	25-36 (3.5-5.0)
Pitman Arm-to-Sector Shaft	72-101 (10-14)
Column Tube Clamp	22-33 (3.0-4.5)
Steering Wheel Nut	22-29 (3.0-4.0)
Pinch Bolt.....	14.5-22 (2.0-3.0)